

## Antimicrobial Photodynamic Effects of Polychromatic Light Activated By Magnetic Fields to Bacterial Viability

Suryani Dyah Astuti<sup>1,2\*</sup>, R. Arif Wibowo<sup>2</sup>, Abdurachman<sup>3</sup>, Kuwat Triyana<sup>4</sup>

1. Department of Biomedical Engineering Post Graduate School Airlangga University
2. Department of Physics Faculty of Science and Technology, Airlangga University
3. Department of Anatomy, Faculty of Medicine, Airlangga University
4. Department of Physics, Faculty of Mathematics and Natural Sciences, Gadjah Mada University.

### Abstract

The *Escherichia coli* (*E. coli*) is Gram negative bacteria, that normally live in the digestive tracts of humans and animals, can cause bloody diarrhea, severe anemia or kidney failure and other illnesses which can lead to death. Systemic therapy with antibiotic cause bacteria resistant. So, an alternative method is needed, one of them is Photodynamic therapy (PDT). This research aims to investigate antimicrobial photodynamic effects of the light emitting diode (LED) activated by magnetic fields 1.8 mT irradiation to bacteria viability.

To determine the antimicrobial effect of treatments, three measurements of bacterial colony growth (in %) were carried out. Three measurements groups as follow: Groups I to measurements the effects of LED irradiation by varying wavelength (469nm, 541 nm and 626 nm); Groups II to measurements effects of magnetic fields 1.8 mT to antimicrobial efficacy; Groups III to determine the effects and efficacy of LED 541 nm and magnetic fields irradiation with varying LED intensity (0.62, 2.50, 6.27, and 8.21) mW/cm<sup>2</sup> and time irradiation (20, 30, 40, 50) minutes, respectively. The suspension was planted on sterile media and incubated at a temperature of 37°C for 24 hours. After incubation, the number of colony-forming units per milliliter (CFU/ml) was determined. The results were analyzed by analysis of variance (ANOVA) and the Tukey test. A P value ≤0.05 was considered to indicate a statistically significant difference.

The LED treatment group 469 nm, 541 nm and 626 nm resulted in statistically significant decrease of CFU ( $p < 0.05$ ) compared to each other. The LED 541 nm treatment group with magnetic fields resulted significantly differ with treatment group without magnetic fields. The LED 541 nm treatment with magnetic fields 1.8 mT at various light intensity and time irradiation resulted significantly differ each other ( $p < 0.05$ ). LED irradiation with intensity 6.27 mW/cm<sup>2</sup> and time irradiation 50 minutes (energy dose 18.81 J/cm<sup>2</sup>) resulted highest decreases the number of bacteria *E. coli* 80%.

LED irradiation combined by magnetic fields can improve the efficacy of antimicrobial photodynamic effects.

*Experimental article (J Int Dent Med Res 2017; 10: (1), pp. 00-00)*

**Keywords:** Antimicrobial, LED, magnetic fields, *E. coli*.

**Received date:**

**Accept date:**

### Introduction

*Escherichia coli* (*E. coli*) bacteria is the name of bacterium that normally live in the digestive tracts of humans and animals. There are many types of *E. coli*. Most of them are

harmless and actually are an important part of a healthy human intestinal tract. However, some strain of *E. coli* are pathogenic, meaning they can cause illness, either bloody diarrhea or illness outside of the intestinal tract, severe anemia or kidney failure, respiratory illness and pneumonia, and other illnesses which can lead to death. The types of *E. coli* that can cause diarrhea can be transmitted through contaminated water or food, or through contact with animals or persons<sup>1-2</sup>. *E. coli* is a gram-negative bacteria, facultative anaerobe and chemoorganotrophic. It lives on the temperature that ranges from 20 to 40 °C, but

#### \*Corresponding author:

Department of Biomedical Engineering  
Post Graduate School and Department of Physics  
Faculty of Science and Technology, Airlangga University.  
E-mail: [suryanidyah@fst.unair.ac.id](mailto:suryanidyah@fst.unair.ac.id)

the optimum temperature is 37 °C. Systemic therapy with antibiotic cause bacteria resistant<sup>3-4</sup>. So, an alternative method is needed for a disinfectant process that is chemically free, and one of them is using the method of antimicrobial Photodynamic Therapy (aPDT). Antimicrobial PDT (aPDT) also known as photodynamic inactivation (PDI)<sup>5</sup>, lethal photosensitization, photoactivated disinfection (PAD) or photodynamic antimicrobial chemotherapy (PACT)<sup>6</sup> is an alternative antibacterial, antifungal, and antiviral treatment for drug-resistant organisms. PDT is a non-thermal photochemical reaction involving the simultaneous presence of visible light, oxygen and photosensitizer (PS) to generate various of radical oxygen species (ROS)<sup>7-8</sup>. Photodynamic therapy might be useful as an alternative approach for the antimicrobial treatment<sup>9-10</sup>.

In nature some of the bacteria (*E. coli*) containing porphyrin compounds as endogenous PS. Most bacteria use hemA biosynthetic pathway to produce porphyrins from the precursor. In the bacterial, the product of hemA gene is the ALA synthase<sup>9</sup>. ALA is formed by an ALA synthase that catalyzes the pyridoxal phosphate-dependent condensation of succinyl-coenzyme A (succinyl-CoA) and glycine. There are many techniques to increase production of ALA, one of which is magnetic field application. Additionally, it has been reported by other researchers that the application of magnetic field causes stress on bacteria cells and activates ALA dehydratase (ALAD) genes (an important enzyme in porphyrin synthesis) to increase the production of ALA and porphyrin<sup>11</sup>. Increasing endogen porphyrin production can improve light absorption.

Light absorption process by photosynthesizing molecules (porphyrin) in bacteria followed by triggering the activation of chemical reactions that produce various reactive oxygen species (ROS). ROS are the product of photochemistry reaction that inactivates microbial cell<sup>12</sup>. It is the delaying of metabolism cell activity due to cytoplasmic membrane damage caused by peroxidation of oxygen reactive. PDI requires a source of light that activates the PS by exposure to low-power visible light at a specific wavelength. In the past, PS activation was achieved via a variety of light sources, LED and any various dye laser<sup>13</sup>. These laser systems are complex and expensive. For large area, non-

coherent light sources light tungsten filament, quartz halogen, and xenon arc are often used for irradiation treatment in PDT<sup>14-17</sup>. Light emitting diodes (LED), have also been applied in PDT<sup>18-20</sup>. These light sources are much less expensive and are small, lightweight, and highly flexible.

This paper reports our investigation about effect and efficacy of photodynamic LED combined with magnetic fields irradiation on the inactivate cell cultures of *E. coli* ATCC 25922. In this case, the magnetic field of 1.8 mT from Helmholtz coil was an optimum condition as reported previously<sup>21</sup>. The use of the magnetic field was intended to promote the biosynthesis of photosynthesizer molecules in a bid to increase the number of light absorber molecules.

## Materials and methods

### Bacterial Strain and Culture Conditions

The strain used in this study was *E. coli* ATCC 25922 that was obtained from the American Type Culture Collection, the USA. The bacteria colony were grown for about 18 hours on *Mac Conkey* Agar plates. The bacterial colony was then transferred into Nutrient Broth. The initial optical density of the culture was between 0.2 to 0.25 at the wavelength of 660 nm. Cultures were allowed to grow aerobically at 37 °C with aeration until they reached an optical density of 0.5 at 660 nm. The bacteria were grown aerobically on nutrient agar plates and inoculated on fresh plates once every week. The re-plated stock culture was about 4 to 5 days old, and a sterile glass rod was used to scrape off the bacteria. The bacteria were diluted by adding sterile water until the optical density was 0.003 with a number of bacteria colony were  $2.67 \times 10^7$  CFU (for *E. coli* bacteria based on preliminary research). The irradiation of the *E. coli* bacteria was done in vitro in Petri dishes.

### Apparatus Chamber for Illumination Treatment

For the light source, it consisted of LED array. The irradiation consisted of a LED array, a petri dish holder under servo motor that rotating at 5 rpm. Samples were put in the rotated sample holder in the middle of Helmholtz coils. Rotating the petri dish holder ensured that all bacteria were exposed to the same average level of light. The servo motor was used to rotate the sample holder, where the petri dish was placed, so that the light illumination was expected to be

homogenous in the sample. The LED series is an electronic series which function is to turn on the LEDs through a different potential of the power supply. Helmholtz coil is an electronics series that serve as the source of low-frequency magnetic fields that is initiated through different potentials.

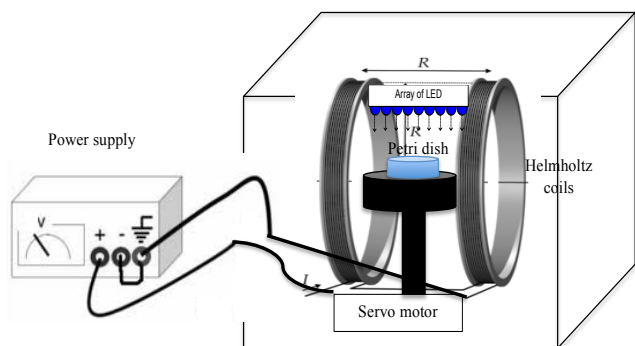

(a)

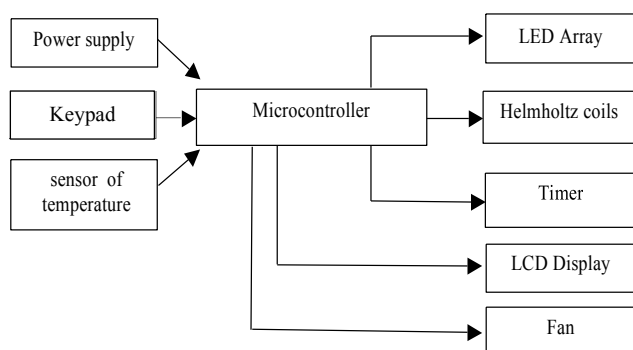

(b)

**Figure 1.** (a) Schematic apparatus chamber for illumination treatment of samples; (b) Workflow diagram of apparatus chambers for illumination.

Magnetic fields source used in this research is two identical coils with outer diameter 13 cm, inner diameter 6 cm, and 1000 twists. The coil was made of copper wire with a diameter of one mm and the brass type resistant of  $1.72 \times 10^{-8} \Omega m$ . The resistance of each coil is 11  $\Omega$ , because these two coils are set in series so that the total resistant of the two coils is 22  $\Omega$ . While the current source utilized is DC power supply with current specification 0 – 0.5 A. Finally the bacteria culture was transferred to dishes for LEDs irradiation. The main apparatus and chamber for illumination treatment is shown Fig.1.

### Antimicrobial Effect of Treatments Against *E.coli*

To determine the antimicrobial effect of treatments, three measurements of bacterial

colony growth (in %) were carried out. Three measurements groups as follow: Groups I to measurements the effects of LED irradiation by varying wavelength (469nm, 541 nm and 626 nm); Groups II to measurements effects of magnetic fields 1.8 mT to antimicrobial efficacy; Groups III to determine the effects and efficacy of LED 541 nm and magnetic fields irradiation with varying LED intensity (0.62, 2.50, 6.27, and 8.21) mW/cm<sup>2</sup> and time irradiation (20, 30, 40, 50) minutes, respectively. After irradiation, the bacteria were incubated at room temperature for 24 hours. Next, each sample was taken out from the incubator, and After incubation, the number of colony-forming units per milliliter (CFU/ml) was determined. The decrease in bacterial colony growth (D) was calculated using  $D(\%) = |(C-T)/C| \times 100\%$ , where C and Y are the total numbers of bacterial colony, under treatment and control, respectively. The results were analyzed by analysis of variance (ANOVA) and the Tukey test. A P value  $\leq 0.05$  was considered to indicate a statistically significant difference.

## Results

### Light source and magnetic field characterization

The output power of LED array in the various pulse width of modulation (PWM) is depicted in Fig. 2(a). It was measured using a Silicon detector 818 SL at a wavelength range of 400 nm – 1100 nm. For the PDI application, light with power density and exposure duration plays an important role in certain types of interactions with the target. Photochemical interaction on PDI occurs in exposure duration more than one second with a low optical power density in the mW range<sup>22</sup>. Therefore, the LED instrument has been designed to meet the requirements of the photodynamic mechanism in bacteria.

Figure 3(a) shows the decrease (in %) of a total number of *E. coli* bacterial colony after LEDs irradiation at various wavelengths, i.e. 469 nm, 541 nm, and 626 nm. The light at 541 nm shows the highest performance for decreasing bacterial colony of more than 70%. On the other hand, Fig. 3(b) shows the reduction in the bacterial colony by varying power (intensity) and time exposure of light irradiation.

It is clear that the group treatment with LEDs 541 nm at power density 6.27 mW/cm<sup>2</sup> for 50 minutes (equivalent with the energy density of

18.81 J/cm<sup>2</sup>) combined with 1.8 mT magnetic fields can decrease of *E. coli* bacterial colony by 80%.

result that exposure of LED with light intensity 6.27 mW/cm<sup>2</sup> and time irradiation 50 minutes (Energy dose 18.81 J/cm<sup>2</sup>) resulted highest decreases the number of bacteria *E.coli* 80%.

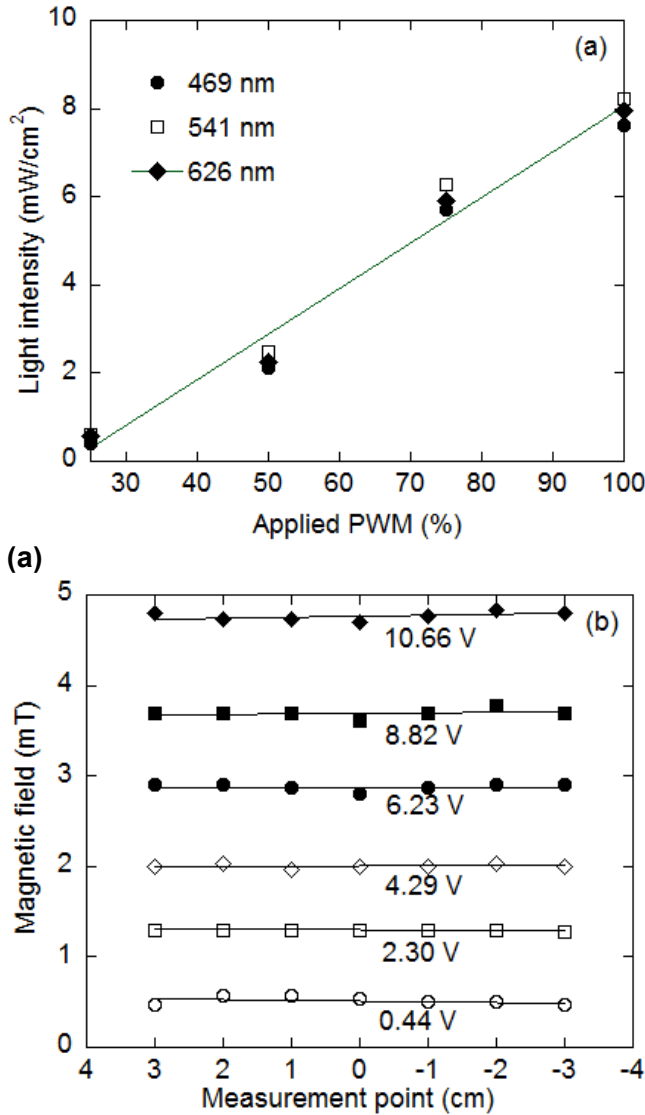
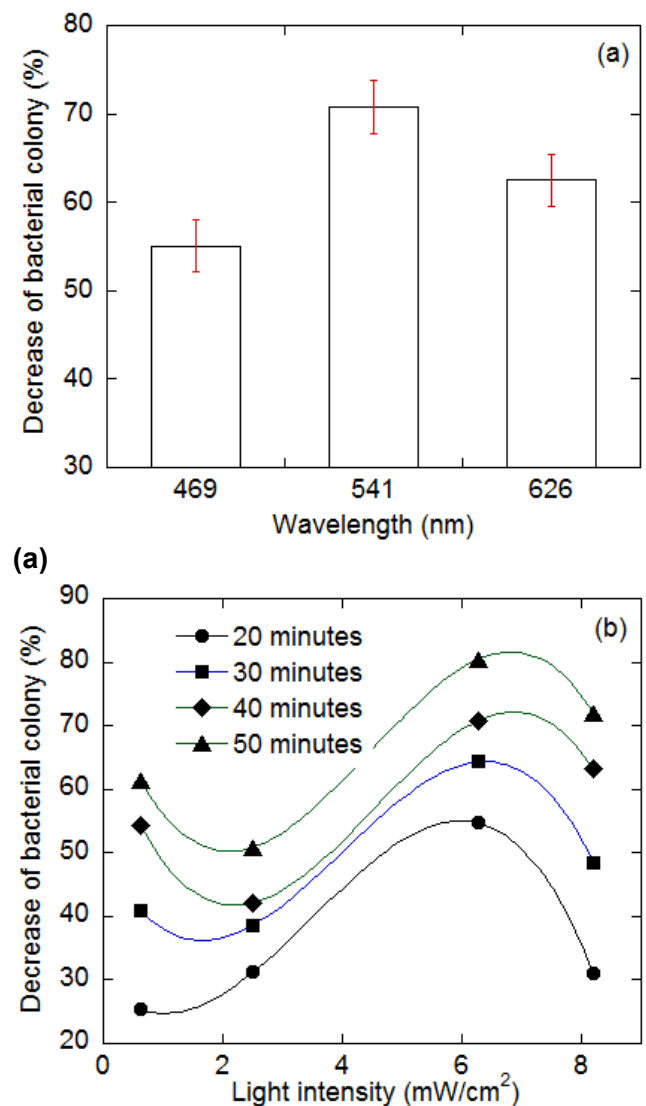

**Figure 2.** (a) The intensity of LED irradiation at a distance of 2 cm for varying PWM settings; (b) The magnetic field uniformity when the distance between two coils was 6 cm with applied voltage variations.

The LED treatment group 469 nm, 541 nm and 626 nm resulted in statistically significant decrease of CFU ( $p < 0.05$ ) compared to each other. The LED 541 nm treatment group with magnetic fields resulted significantly differ with treatment group without magnetic fields. The LED 541 nm treatment at various light intensity and time irradiation resulted significantly differ each other ( $p < 0.05$ ). The Tukey post hoc test

## Discussion

As mentioned in the previous report<sup>21</sup>, the magnetic fields source consists two identical coils with an outer diameter 13 cm, inner diameter 6 cm, and the number of twists is 1000. Meanwhile, the coil is made of copper wire with one mm diameter and brass resistant of  $1.72 \times 10^{-8} \Omega \text{ m}$ .



**Figure 3.** (a) The decrease of bacterial colony due to the application of 1.8 mT magnetic field combined with various wavelengths of LED light; (b) The decrease of bacterial colony due to the

application of 1.8 mT magnetic field combined with different exposure times and light intensities of LED 541 nm.

The resistance of each coil is 11  $\Omega$ , and the total resistance of the two coils is 22  $\Omega$ . The source of current is DC power supply with specification current up to 0.5 A. The strength of magnetic field at the different position of measurements indicated that the more distant the magnetic fields position, the lower magnetic field strength measured. Magnetic fields strength uniformity can be achieved at a distance of 6 cm between the two coils, on 6.32 V and 1.8 mT magnetic fields. The magnetic field is relatively uniform at voltage input of 0.44 V when the distance between coils is 6 cm (Fig. 2b).

In this study, the LED light produces spectrum at a visible wavelength of 400 nm to 650 nm. PDI requires a source of light that activates the PS by exposure to low-power visible light at a specific wavelength<sup>23</sup>. This wavelength range is in accordance with the absorption spectrum of porphyrin. It has been also reported that the main porphyrin on *E. coli* bacteria is a type of uroporphyrin (65.3-85.3%) with an absorber spectrum imbibed in blue light<sup>24</sup>.

Therefore, the LED light source can be applied for photo-inactivation on bacteria with porphyrin endogenous. In the PDI application, the light power density and the time exposure of light irradiation play a significant role in the type of interaction with the target (Fig. 3(b)).

Moreover, the photochemistry interaction on PDI occurs within the exposure time more than one second in low optical density power within the range mW<sup>25</sup>. It means that the irradiation energy dose of LED on an area irradiation (energy density) in J/cm<sup>2</sup> is the amount of energy irradiation (power times the period of irradiation) divided by the area of irradiation. The proper energy dose will activate the occurrence of chemical reactions that produce various reactive oxygen species that subsequently triggers photo-inactivity on bacteria.

The success of bacterial photoinactivation determined by compliance of light wavelength with the absorption spectrum of PS for the occurrence of porphyrins molecules excitation. Another deciding factor is the radiation energy dose. The appropriate energy dose will activate chemical reaction which produces a wide

range of reactive oxygen species that cause photoinactivation in bacteria. In this study, a combination of radiation dose factors of power and the 1.8 mT magnetic field influences the decrease of the bacterial colony of *Bacillus E. coli*. The result indicates that the use of LED 541 nm super bright locally produced as in this research was effective in decreasing the number of the colony *Bacillus E. coli* ATCC 25922 by 80% on energy dose 18.81 J/cm<sup>2</sup> (the intensity 6.27 mW/cm<sup>2</sup> and time duration of irradiation 50 minutes). The improved of irradiating time resulted in a decrease of a bacterial colony.

As comparison in other study, Lipovsky *et al.*<sup>26</sup> who examine photoinactivation of bacteria *Staphylococcus aureus* (*S. aureus*) on strain 101 (*sensitive methicillin*) and strain 500 (*resistant methicillin*) with irradiation halogen lamps 415 nm, the optimum energy dose 120 J/cm<sup>2</sup> (the intensity 100 mW/cm<sup>2</sup> and the length time irradiation 20 minutes) produce decreased number of colony bacteria by 90 percent. Using the same media with a wavelength of 455 nm and similar energy density produce a 50% decrease. Moreover, a photo-inactivity bacteria *S. aureus* by using xenon lights is optimal at 205 nm with the dose 23.5 J/cm<sup>2</sup> (the intensity 3.27 mW/cm<sup>2</sup> for 2 days) has been reported resulting a decrease in bacterial colony up to 24%. While that of using blue LED of 405 nm with the energy dose of 36 J/cm<sup>2</sup> (the intensity 10 mW/cm<sup>2</sup> for about 60 minutes) resulting a decrease in bacterial colony up to 14%<sup>27</sup>.

Differences of PDT inactivation effect on Gram-positive and Gram-negative lies in the structure of the cell wall<sup>28</sup>. On the outside wall of Gram positive bacteria with a thickness of 15-80 nm consisting of 100 layers peptidoglycan associated with lipoprotein that binds to the outer membrane and the peptidoglycan teichuronic acid negatively charged relatively porous. The outer membrane of Gram-negative bacteria consisting of lipopolysaccharide, phospholipids, and lipoproteins. Outer membrane serves as a barrier against the damaging effects of the outside of the cell and has a permeability to certain molecules. The outer membrane forms an effective barrier permeability. Photochemical reactions type I operative for Gram (+) and reaction type II operative to Gram (-).

Porphyrin is a metastable state, which can donate the excited state energy to a ground state of the oxygen molecule, whereby a singlet

oxygen ( $^1O_2^*$ ) molecule is created. This type of photosensitization reaction is called a type I reaction. In the reaction, the excited photosensitizer acts as an oxidant and the resulting effect is a transfer of either a hydrogen atom or an electron, yielding active radicals or radical ions that may cause damage to neighboring biomolecules<sup>29</sup>. Reactions superoxide radical  $O_2^-$  may be formed. Subsequently stronger oxidizers like peroxide  $OH^-$  and hydroxyl  $HO^-$  radicals are formed.

A basic mechanism has been proposed to explain the lethal damage of the bacteria by photosensitization is due to the damage of the cytoplasmic membrane, allowing leakage of cellular contents or inactivation of membrane transport systems and enzymes<sup>8</sup>. The alteration of cytoplasmic membrane proteins has been shown by<sup>30-32</sup>. A chemical reaction is induced production of singlet oxygen, and subsequent reaction sequences (as direct membrane damages) is likely to be the main cause of inactivation. However, even if the cell does not undergo lysis, irreversible  $K^+$  loss may be considered as the initial step toward cell death<sup>20</sup>.

Magnetic fields cause stress in bacterial cells and activates genes ALA dehydratase (ALAD), which is a key enzyme from a synthesis porphyrin<sup>11</sup>, which increases the production of porphyrin photosensitizer<sup>33</sup>. The increased photosynthesizer endogenous in bacteria will increase reactive oxygen production that caused peroxidation in lipid and membrane proteins bacteria. The effect of the magnetic field for therapeutic use has been explored. A study by Pang *et al.*<sup>34</sup> shows that there is a synergy between photodynamic and electromagnetic on the therapy of cancer cell leukemia that significantly decreases the viability of cancer cells through various photo-synthesizer.

## Conclusions

Magnetic fields can increase the production of porphyrin photosensitizer and improve the efficacy of antimicrobial effect. Results of the study showed that LED 541 nm irradiation with light intensity  $6.27 \text{ mW/cm}^2$  and time irradiation 50 minutes (energy dose  $18.81 \text{ J/cm}^2$ ) and magnetic field strength 1.8 mT is optimal to reduce the percentage of *E. coli* bacteria colony by 80%. So LED irradiation combined by magnetic fields can improve the

efficacy of antimicrobial photodynamic effects.

## Declaration of Interest

The authors report no conflict of interest and the article is not funded or supported by any research grant.

## References

1. Kennedy KJ, Roberts JL, Collignon PJ. Escherichia coli bacteraemia in Canberra: incidence and clinical features. *Med J Aust* 2008;188:209-13.
2. Laupland KB, Church DL, Vidakovich J, Mucenski M, Pitout JD. Community-onset extended-spectrum  $\beta$ -lactamase (ESBL)-producing Escherichia coli: importance of international travel. *J Infect* 2008;57:441-8.
3. Johnson JR, Sannes MR, Croy C, et al. Antimicrobial drug-resistant Escherichia coli from humans and poultry products, Minnesota and Wisconsin, 2002-2004. *Emerg Infect Dis* 2007;13:838-46.
4. Johnson JR, McCabe JS, White DG, Johnston B, Kuskowski MA, McDermott P. Molecular analysis of Escherichia coli from retail meats (2002-2004) from the United States National Antimicrobial Resistance Monitoring System. *Clin Infect Dis* 2009;49.
5. Grossweiner LI. *The Science of Phototherapy - An Introduction*. Netherland; 2005.
6. Wainwright M, Pr P. Review Photodynamic antimicrobial chemotherapy (PACT). *J Antimicrob Chemother*. 1998;42:13-28.
7. Rusydi F., Agusta, M.K, Saputra, A.G, and Kasai K., A First Principles Study on Zinc-Porphyrin Interaction with  $O_2$  in Zinc-Porphyrin(Oxygen) Complex, *Journal of the Physical Society of Japan* 81 (2012) 124301.
8. Derosa, M. C. and R. J. Crutchley, 2002, Photo-sensitized Singlet Oxygen and Its Application, *Coord. Chem. Rev.* 2002; 233:351-371.
9. Nitzan Y, Gutterman M, Malik Z, Ehrenberg B. Inactivation of gram-negative bacteria by photosensitized porphyrins. *Photochem Photobiol.* 1992; 55, 1:89-96.
10. Hamblin MR, Hasan T. Photodynamic therapy: A new antimicrobial approach to infectious disease? *Photochem Photobiol Sci.* 2004; 3, 5:436-450.
11. Utsunomiya T., Yamane Y., Watanabe M., Sasaki K., Stimulation of Porphyrin Production by Application of an External Magnetic Field to a Photosynthetic Bacterium, *Rhodobacter sphaeroides*, *Journal of Bioscience and Bioengineering* 95(2003), 4:401-404.
12. Spearandio FF, Huang Y-Y, Hamblin MR. Antimicrobial Photodynamic Therapy to Kill Gram-negative Bacteria. *Recent Pat Drug Discov.* 2013;8(2):108-120.
13. Konopka K, Goslinski T. Critical Reviews In Oral Biology & Medicine Photodynamic Therapy in Dentistry. *J Dent Res.* 2007;86(8):694-707.
14. Rios A, He J, Glickman GN, Spears R, Schneiderman ED, Honeyman AL. Evaluation of photodynamic therapy using a light-emitting diode lamp against *Enterococcus faecalis* in extracted human teeth. *J Endod.* 2011;37(6):856-859.
15. da Frota MF, Guerreiro-Tanomaru JM, Tanomaru-Filho M, Bagnato VS, Espir CG, Berbert FL. Photodynamic therapy in root canals contaminated with *Enterococcus faecalis* using curcumin as photosensitizer. *Lasers Med Sci.* 2015;30(7):1867-1872.
16. Tavares A., Carvalho C. M. B., Faustino M. A., Neves M. G. P. M. S., João P. C. Tomé, Tomé A. C., Cavaleiro J. A. S., Cunha Â., Gomes N. C. M., Alves E. and Almeida A., Antimicrobial Photodynamic Therapy: Study of Bacterial Recovery Viability and Potential Development of Resistance after Treatment, *Marine Drug*,s 2010, 8(1), 91-105.

17. Rolim J. P.M.L., de-Melo M. A.S., Guedes S. F., Albuquerque-Filho F. B., J. R. de Souza, Nogueir N. A.P., Zanin I. C.J., Rodrigues L. K.A., The antimicrobial activity of photodynamic therapy against *Streptococcus mutans* using different photosensitizers, *Journal of Photochemistry and Photobiology B: Biology*, 2012, 106 (2012) 40–46.
18. Setiawatie E.M., Astuti S.D. and Zaidan A.H, An in vitro Antimicrobial Photodynamic Therapy (aPDT) with Blue LEDs to Activate Chlorophylls of Alfalfa *Medicago sativa* L on *Aggregatibacter actinomycetemcomitans*. *Journal of International Dental and Medical Research*, (2016), (9)2.
19. Pieslinger A, Plaetzer K, Oberdanner CB, Berlanda J, Mair H, Krammer B, *et al.*. Characterization of a simple and homogenous irradiation device based on light-emitting diodes: a possible low-cost supplement to conventional light sources for photodynamic treatment. *Med Laser Appl* 2006; 21:277-283.
20. Daniel Barolet. Light-Emitting Diodes (LEDs) in Dermatology, *Semin Cutan Med Surg* 2008; 27:227-238.
21. Astuti S.D., Dwi GD N., Supriyanto A., Triyana K., Photodynamic Combined with Magnetic Field Applications for Viability Activation of Anaerobic Photosynthetic Bacteria, *Applied Mechanics and Materials*, 2015, 771, 141-144.
22. Ben Cox, Introduction to *Laser-Tissue Interaction, Optic in Medicine*, 2013, 5-18.
23. Lipovsky A., Nitzan Y., Gedanken A., and Lubart R., Visible Light-Induced Killing of Bacteria as a Function of Wavelength: Implication for Wound Healing, *Lasers in Surgery and Medicine*, 2010, 42:467–472.
24. Nitzan Y. and Kauffman M., Endogenous Porphyrin Production in Bacteria by  $\delta$ -Aminolaevulinic Acid and Subsequent Bacterial Photoeradication, *Lasers Med Sci* 1999, 14:269-277.
25. Niemz M.H, *Laser-Tissue Interaction, Fundamentals and Applications*, Third enlarged edition, Springer-Verlag Berlin, 2007.
26. Lipovsky A., Nitzan Y., Friedmann H., Lubart R., Sensitivity of *Staphylococcus aureus* Strains to Broadband Visible Light, *Journal of Photochemistry and Photobiology*, 2009, 85(1), 255-260.
27. Maclean M., Macgregor S. J., Anderson J. G., Woolsey G. A., High-Intensity Narrow Spectrum Light inactivation and Wavelength Sensitivity of *Staphylococcus aureus*, research letter, Federation of European Microbiological Societies Published by Blackwell Publishing Ltd. 2008, 285, 227–232.
28. Jori G, Fabris C, Soncin M, et al. Photodynamic therapy in the treatment of microbial infections: Basic principles and perspective applications. *Lasers Surg Med*. 2006;38(5):468-481. doi:10.1002/lsm.20361.
29. Ramberg K., Melø T.B., Johnsson A., In Situ Assessment of Porphyrin Photosensitizer in *P.acnes*, *Z.Naturforsch*, 2004, 59C, 93-98.
30. Valduga G., Breda B., Giacometti G. M., Jori G., Reddi E., 1999, Photosensitization of Wild and Mutant Strains of *E.coli* by Meso-tetra (N-methyl-4-pyridyl) Porphine, *Biochem.Biophys. Res. Commun.*, 1999, 256(1), 84-88.
31. Bertolini G., Rossi F., Valduga G., Jori G., Van Lier J., Photosensitizing Activity of Water and Lipid Soluble Pthalocyanines on *Escherichia coli*, *FEMS Microbiol. Letters*, 71(1-2), 149-155.
32. Malik Z., Babushkin T., Sher S., Hanania J., Ladan H., Nitzan Y., Salzberg S., Collapse of  $K^+$  and ionic balance during photodynamic inactivation of leukemic cells, erythrocytes and *Staphylococcus aureus*, *International Journal of Biochemistry*, 1993, 25(10), 1399–1406.
33. Sasaki K., Watanabe M., Tanaka T., Biosynthesis, biotechnological, production and application of 5-aminolevulinic acid, *Applied Microbiology and Biotechnology*, 2002, 58(1), 23-29.
34. Pang L., Baciuc C., Traitcheva N., Berg H., Photodynamic effect on cancer cells influenced by Magnetic fields, *Journal of Photochemistry and Photobiology B: Biology*, 2001, 64, 21-26.