

# Gasoline level sensor based on displacement sensor using fiber coupler.

*by* Samian Samian

---

**Submission date:** 10-May-2019 07:37PM (UTC+0800)

**Submission ID:** 1128284254

**File name:** 1-s2.0-S0263224114003431-main.pdf (1.07M)

**Word count:** 3596

**Character count:** 17957



## Gasoline level sensor based on displacement sensor using fiber coupler



Samian\*, G.Y.Y. Yhosep, A.H. Zaidan, Herlik Wibowo

Physics Department, Faculty of Science and Technology, University of Airlangga Surabaya, Indonesia

### 5 ARTICLE INFO

#### Article history:

Received 30 October 2013

Received in revised form 6 February 2014

Accepted 14 August 2014

Available online 17 September 2014

#### Keywords:

Gasoline level sensor  
Hydrostatic pressure  
Displacement sensor  
Fiber coupler

### A B S T R A C T

A simple and fire safe gasoline level sensor has been designed based on displacement sensor using fiber coupler. The sensing principle is to detect displacement of reflector, which is attached to membrane (reflector displacement device), due to the change of gasoline hydrostatic pressure. The displacement of reflector can be detected using fiber coupler from the change of optical power light reflected by the reflector. Three kinds of reflector displacement device used in this experiment are one-layer, two-layer, and three-layer membrane. The experimental results are 0–180 cm of dynamic range, 100–140 cm of linear range, 3.2 mV/cm of sensitivity, and 0.6 cm of resolution for reflector displacement device with one-layer membrane for emptying the tank process. The hysteresis data for emptying and filling the tank process yields the mean of difference 20% for one-layer membrane.

© 2014 Elsevier Ltd. All rights reserved.

### 1. Introduction

Liquid level detection system can operate based on the principle of capacitance, electro-mechanic, ultrasonic, and optic. The ultrasonic principle is applied by measuring time interval required by ultrasonic wave to propagate from the source to the liquid surface and then back to the detector. For optical method, various kinds and configurations of optical device have been able to detect the liquid level. Some of the technics are opto-fluidic technic using Electronically Controlled Variable Focus Lens Devices [1], Prism connected to fiber optic [2], Fiber Bragg Grating connected to buoy [3], and plastic optical fiber polished at its cladding [4]. Gasoline level detection system requires sensor that does not cause fire spark and explosion. The electric signal and mechanical motion, therefore, are not appropriate used for gasoline level sensor.

Fiber coupler is an optical device that can be used as optical power divider. Fiber coupler had been applied as

displacement sensor with target flat mirror [5]. The displacement of the target is detected from the change of target reflected light intensity received via fiber coupler sensing port. The change of light intensity is translated to the change of applied optical detector output voltage.

In this paper, the concept of displacement sensor using fiber coupler is applied as a basic principle to detect gasoline level. The detection mechanism uses gasoline hydrostatic pressure to displace the reflector which is attached to the membrane located in the bottom of gasoline tank. This detection mechanism does not use electrical signal or mechanical motion which can potentially cause fire spark. The developed level gasoline sensor is, therefore, free of fire and explosion risk.

### 2. Sensor work mechanism

The design of gasoline level sensor based on displacement sensor using fiber coupler is shown in Fig. 1. In Fig. 1, incoming laser beam of power  $P_{in}$  is transmitted via input port to the 50:50 fiber coupler. Half of the incoming beam is transmitted via sensing port and illuminates

\* Corresponding author.

E-mail address: [samian@fst.unair.ac.id](mailto:samian@fst.unair.ac.id) (Samian).

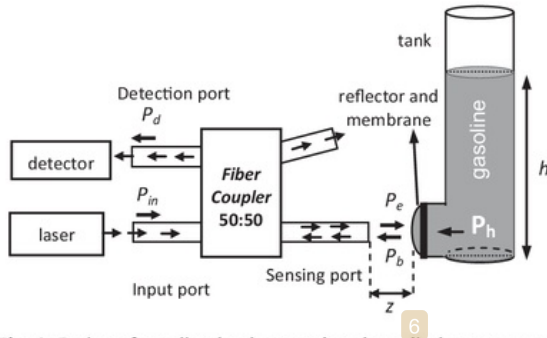

Fig. 1. Design of gasoline level sensor based on displacement sensor using fiber coupler.

the reflector, which is attached to the membrane surface. The arriving beam of power  $P_e$  is then reflected by reflector. The reflected beam of power  $P_b$  enters and transmitted via sensing port back to the 50:50 fiber coupler. Half of reflected beam of power  $P_d$  is coupled to the detection port and detected by optical detector. The power light  $P_b$  depends on the position of reflector from the sensing port  $z$ .

The relation between the power light that is received by detector  $P_d$  and the position of reflector from the sensing port  $z$  is given by

$$P_d = P_o \left[ 1 - \exp \left( -\frac{2}{(cz + 1)^2} \right) \right]. \quad (1)$$

The power light  $P_o$  is given by

$$P_o = 1.15cr(1 - cr) \left( 10^{-0.1Le} - 10^{-0.1D} \right)^2 P_{in}, \quad (2)$$

where  $cr$ ,  $Le$ , and  $D$  are coupling ratio, excess loss, and directivity of fiber coupler respectively. The constant  $c = (2 \tan^{-1} NA) / a$  depends on numeric aperture  $NA$  and radius  $a$  of the optical fiber that is used to construct fiber coupler [5].

The displacement of reflector, which is attached to the membrane surface, happens due to the change of gasoline level (principle of hydrostatic pressure). Gasoline level  $h$  gives hydrostatic pressure  $P_h$  to the membrane by an amount:

$$P_h = \rho gh, \quad (3)$$

where  $\rho$  and  $g$  are gasoline density and gravitation acceleration respectively. The displacement of reflector due to the change of hydrostatic pressure is illustrated in Fig. 2.

In Fig. 2,  $d_m$ ,  $d_r$ ,  $R$ ,  $r$ , and  $z$  are membrane diameter, reflector diameter, membrane curvature radius, the change of membrane length, and reflector displacement respectively. The stress  $P_h$  causes strain on the membrane so that the reflector displaces. Then the elastic modulus of membrane is given by

$$Y = \frac{P_h}{\Delta r / r_0}, \quad (4)$$

where  $\Delta r$  and  $r_0$  are the change of membrane length and initial membrane length respectively. Substitute Eq. (3) into Eq. (4) yield

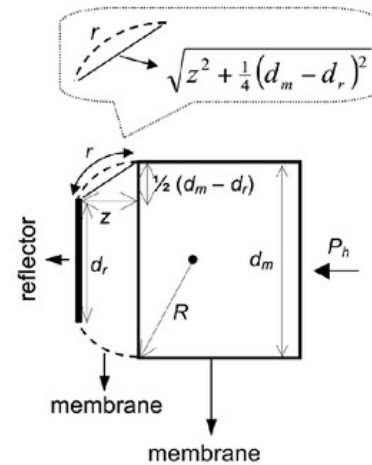

Fig. 2. Evaluating scheme for reflector displacement due to the hydrostatic pressure.

$$h = \frac{Y}{\rho g r_0} \Delta r. \quad (5)$$

From Fig. 2, we have  $r_0 = d_m$  and  $\Delta r = 2r - (d_m - d_r)$ . Using these values, Eq. (4) can be expressed in the form:

$$h = \frac{Y}{\rho g d_m} (2r - (d_m - d_r)). \quad (6)$$

Since the values of  $\rho$ ,  $g$ ,  $d_m$ , and  $d_r$  are fixed, Eq. (5) can be written in the form:

$$h = Y(\alpha r - \beta), \quad (7)$$

where  $\alpha = 2/(\rho g d_m)$  and  $\beta = (d_m - d_r) / (\rho g d_m)$ .

Suppose that the relation between  $r$  and  $z$  can be formulated as  $r = r(z)$ , then Eq. (6) can be expressed in the form:

$$h = Y(\alpha r(z) - \beta). \quad (8)$$

If  $Y$  is assumed to be constant, the relation between  $h$  and  $z$ , in principle, can be expressed as:

$$z = z(h). \quad (9)$$

Using Eq. (8), Eq. (1) can be expressed as:

$$P_d = P_o \left[ 1 - \exp \left( -\frac{2}{(cz(h) + 1)^2} \right) \right]. \quad (10)$$

Eq. (9) is transfer function of the sensor (the relation between  $z$  and  $h$  has not been derived analytically). Using Eq. (9), the change of gasoline level can be detected from the change of optical power light received by optical detector and represented as the change of output voltage of optical detector.

### 3. Experiment

The experimental set-up consists of laser He-Ne (with 632.8 nm wavelength and 15 mW power output), silicon photodetector (Newport), multimode fiber coupler structured  $2 \times 2$  made of plastic (with 1 mm diameter, 1 m length, 50/50 split ratio, 3.7–5.6 dB insertion loss, and



1.6 dB excess loss), microvoltmeter (Leybold), micrometer translation stage, and cylindrical scaled gasoline tank which is made of glass (with 6 cm diameter and 180 cm length) and filled with gasoline ( $715\text{--}780\text{ kg/m}^3$  density at  $15\text{ }^\circ\text{C}$ ). In the bottom of gasoline tank, there are a faucet and a reflector displacement device. Reflector displacement device consist of reflector which is made of aluminum (with 10 mm in diameter and 020 mm thickness), membrane (nitrile polymer) with 008 mm thickness (the elastic modulus is not known), and cylindrical membrane holder which is made of brass with 18 mm outer diameter and 15 mm inner diameter. Reflector is attached to membrane using epoxy glue and membrane itself behaves like a spring. Three kinds of reflector displacement device used in this experiment are one layer membrane, two layers membrane, and three layers membrane. One layer membrane is 0.08 mm in thickness. The reflector displacement  $z$  due to gasoline pressure that acts upon reflector displacement device is shown in Fig. 3 and the schematic diagram of experimental set-up is shown in Fig. 4.

The first step of the experiment is to place the sensing port coincides with and perpendicular to the reflector surface, which is attached to the membrane, when tank is empty. This step is conducted by displacing the sensing port using micrometer translation stage. After the sensing

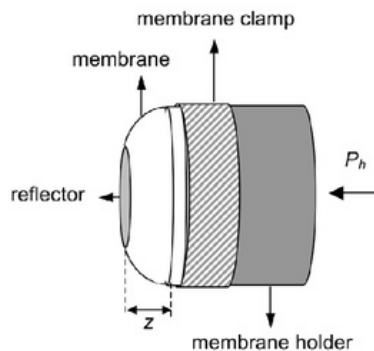

Fig. 3. Illustration of reflector displacement due to gasoline pressure acts upon reflector displacement device.

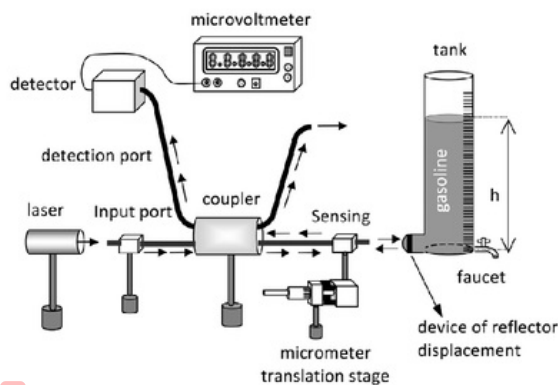

Fig. 4. Experimental set-up of gasoline level sensor using fiber coupler.

port is displaced away from the reflector surface, the tank is fully filled with gasoline. The reflector will undergo the maximum displacement due to the gasoline hydrostatic pressure that acts upon the membrane. After the reflector undergoes the maximum displacement, the sensing port is displaced until it coincides with the center of reflector. The position of reflector can be read on micrometer translation stage scale.

The second step is to couple the incoming laser beam to the input port of fiber coupler so the reflected laser beam can be received by optical detector via detection port. Data for emptying the tank process are obtained by recording optical detector output voltage for each 1 cm drop in gasoline level (gasoline is flowed outward using a faucet) until the gasoline surface reaches the bottom of the tank.

The third step is to obtain data for filling the tank process. This step is done by filling the tank with gasoline from the top of the tank and recording optical detector output voltage for each 1 cm drop in gasoline level until the gasoline surface reaches the maximum level. The second and the third step are repeated three times. These three steps are done for each kind of reflector displacement device.

The last step is to test the stability of sensor recording the optical detector output voltage when gasoline reaches its maximum, half-maximum, and minimum level. The recording is done every 30 s for 900 s. Test of sensor stability gives standard deviation values for each gasoline level. The highest standard deviation value will be used to determine sensor resolution. The test of stability is done for each kind of reflector displacement device.

#### 4. Result and discussion

The experimental result consists of maximum displacement data  $z$  of reflector for each kind of reflector displacement device at the top level of gasoline, optical detector output voltage data as a function of gasoline level which are obtained during emptying and filling the tank process, and the data of sensor stability test. The maximum displacement data is shown in Table 1. The plot of optical detector output voltage with respect to gasoline level for each process and each kind of reflector displacement device is shown in Fig. 5.

Data in Table 1 shows that in the same gasoline level, the more layer of membrane used on the reflector displacement device, the smaller reflector displacement is recorded. This implies that the elastic modulus of membrane is higher as the number of membrane layer decreases. The elastic modulus of membrane will determine the characteristic of sensor. In Fig. 5, in the case of

Table 1

Data of maximum displacement for each kind of reflector displacement device.

Device of reflector displacement	Number of membrane layer	Gasoline level (cm)	Maximum reflector displacement (mm)
1	1	180	4.05
2	2	180	3.10
3	3	180	2.45

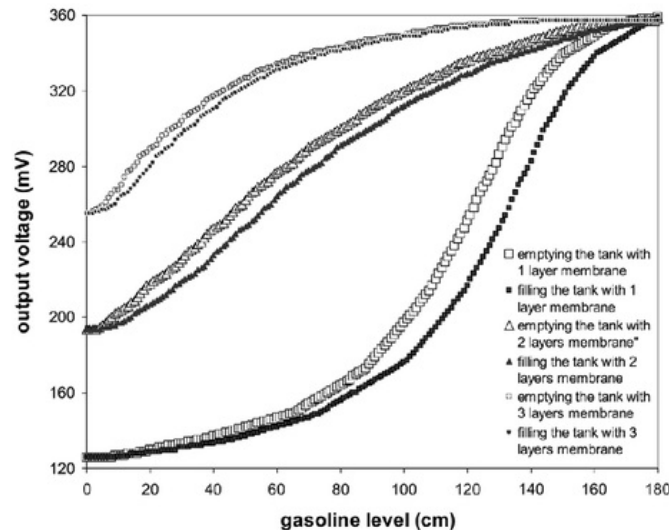

Fig. 5. Plot of optical detector output voltage with respect to gasoline level for emptying and filling the tank process for each kind of reflector displacement device.

lower gasoline level region, the more layer of membrane is used, the bigger slope is obtained. However, in the case of 90–160 cm gasoline level, the result is reversed. On the other hand, the characteristic of sensor using fiber coupler showed smaller slope for long displacement and the bigger change of slope for smaller displacement region [5]. The detection characteristic of gasoline level, which is shown in Fig. 5, is the combination of the elastic modulus of membrane and the characteristic of displacement sensor using fiber coupler. At the higher gasoline level, the bigger elastic modulus of membrane is used, the bigger slope is obtained whereas at the lower gasoline level, the smaller slope is obtained. Of course the results are valid just in the elastic region of membrane.

Gasoline level detection for emptying the tank process yields different data from that of for filling the tank process. Although different, both of them have almost similar character as shown in Fig. 5. The values of detector output voltage for emptying the tank process are generally higher than that of for filling the tank process. This can be understood by realizing that membrane behaves as a spring for the reflector. The thicker the membrane is used, the smaller its elastic modulus. The emptying the tank process begins from the maximum level of gasoline which means that from the maximum pressure. When the gasoline level is reduced, the membrane requires a few times to relax and therefore is not in its ideal condition. The position of reflector in the emptying the tank process is farther than its position in the filling the tank process for the same gasoline level. The viscoelastic property of the material can be used as an analogy here. The less number of membrane layer is used, the bigger the difference. The mean of optical detector output voltage differences between emptying and filling the tank process are 20%, 15%, and 8% for one layer, two layers, and three layers membrane respectively. These values are obtained with the assumption that optical detector output voltage is zero when gasoline level is zero.

The dynamic range of sensor for emptying and filling the tank process for each kind of reflector displacement device are equal, i.e., 180 cm, since the height of tank is 180 cm. Linear regression of output voltage of optical detector with respect to gasoline level for each kind of reflector displacement device are shown in Fig. 6.

For emptying the tank process, the range of linear region of sensor with one-layer, two-layer, and three-layer membrane are 100–140 cm, 10–90 cm, and 10–50 cm, respectively. For filling the tank process, the range of linear region of sensor with one-layer, two-layer, and three-layer membrane are 120–160 cm, 20–100 cm, and 20–50 cm, respectively. The slope of the linear region gives the sensitivity of sensor. For emptying the tank process, the sensitivity of sensor with one-layer, two-layer, and three-layer membrane are 3.1997 mV/cm, 1.3939 mV/cm, and 1.3527 mV/cm, respectively and 3.1653 mV/cm, 1.3734 mV/cm, and 1.33879 mV/cm, respectively for filling the tank process. These data show that the sensitivity of sensor with one-layer membrane is twice the sensitivity of sensor with two-layer membrane, although its range of linear region is almost half the range of linear region of sensor with two-layer membrane.

The sensor stability test yields plot of optical detector output voltage as a function of time interval. Sensor stability test is conducted at 0 cm, 90 cm, and 180 cm gasoline level for each sensor, i.e. with one-layer, two-layer, and three-layer membrane. The data are shown in Fig. 7. The standard deviation of each sensor for 0 cm, 90 cm, and 180 cm gasoline level are shown in Table 2. The biggest standard deviation of each sensor occurs at 0 cm gasoline level. This fact implies that the most unstable measurement occurs when the reflector is the most distant away from the sensing port. The standard deviation can be used to calculate the resolution for each sensor. The resolution of sensor can be determined by dividing the biggest standard deviation by the sensitivity of sensor. The resolution

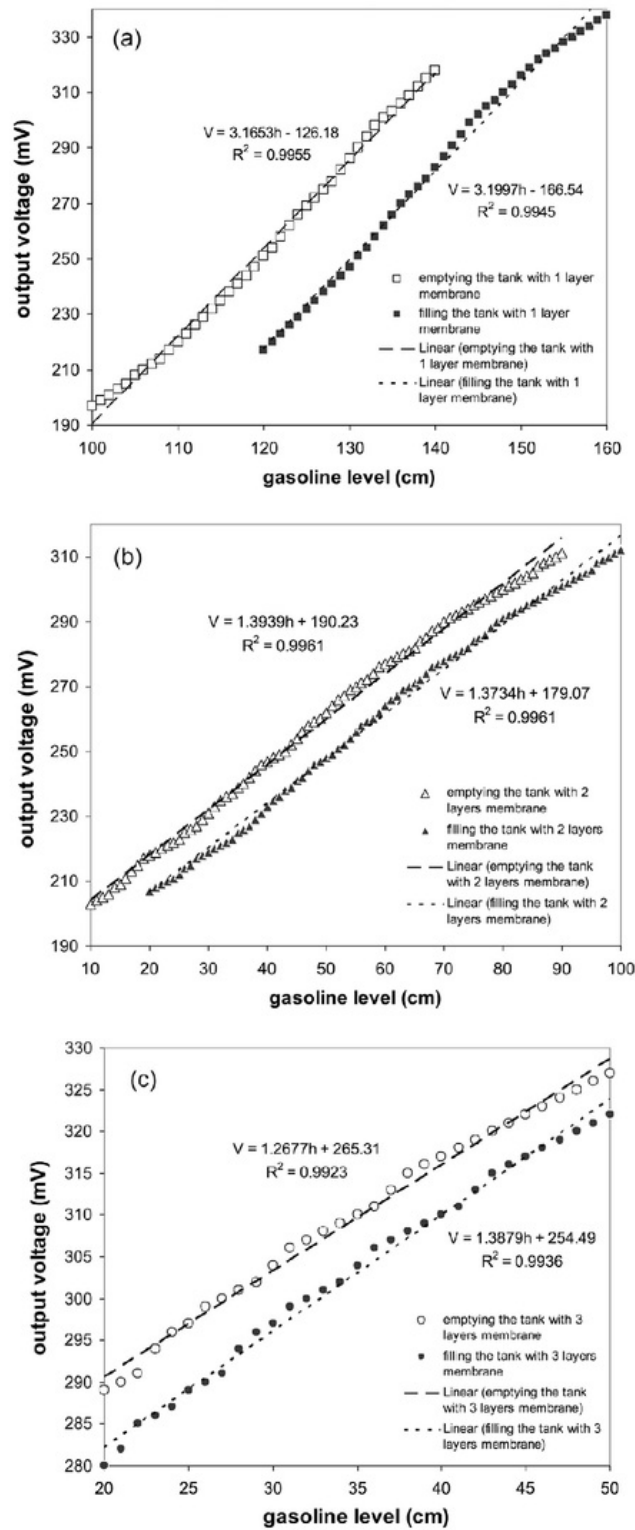

Fig. 6. Linear regression of detector output voltage with respect to gasoline level for (a) one-layer membrane, (b) two-layer membrane, and (c) three-layer membrane.



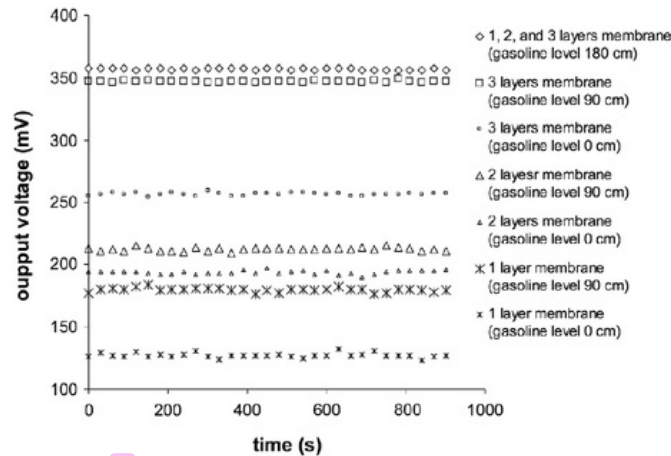

Fig. 7. The plot of detector output voltage as a function of time duration of sensor stability test.

**Table 2**  
Standard deviation values results from sensor stability test.

Number of membrane layer	Gasoline level (cm)	Standard deviation (mV)
1	0	1.9
	90	1.7
	180	0.5
2	0	1.5
	90	1.4
	180	0.5
3	0	1.2
	90	0.7
	180	0.5

of sensor with one-layer, two-layer, and three-layer membrane are 0.6 cm, 1.1 cm, and 0.8 cm, respectively.

Notice that all components of gasoline level sensor are factory-made, except the holder and the reflector. The holder is produced using lathe and the reflector is made of aluminum. The component of sensor that can be considered as unique is reflector displacement device because the process of reflector attachment to the membrane and membrane installation to the holder are done by hand. Therefore, the reproducibility can be maintained by preparing some reflector displacement devices. Each of reflector displacement devices has been made with the same material, size, and number of layer. These reflector

displacement devices are used to detect the gasoline level in the experiment. This procedure has been done for one-layer reflector displacement devices and by different persons. The experimental data shows that the mean standard deviation value of reproducibility in the dynamic range of experiment is 3.75 mV or 0.83%. The same sensor has also been used in experiment to detect water level. The experiment with water produces the same pattern of data as that of with gasoline although the values of sensor parameter are not the same because density of water is different from density of gasoline. Suppose that different kind of membrane, reflector, and fiber coupler are used in the experiment to detect gasoline level, it is more likely that the experiment will give the same pattern of data but with different sensor output (optical power light) measured values.

Overall, the values of gasoline level parameters using fiber coupler with one-layer, two-layer, and three-layer membrane for emptying and filling the tank process are shown in Table 3. The data of sensor characteristic in Table 3 shows that sensor with one-layer membrane is the best choice if what is required is the sensor with high sensitivity and low resolution. However, sensor with one-layer membrane has narrow work region or linear region (40 cm). If what is required is sensor with higher work region, sensor with two-layer membrane is the best choice since it has 80 cm work region. However, sensor with two-layer membrane has low sensitivity and high resolution.

The experimental result shows that gasoline level sensor or other fuel level sensor can be constructed based on

**Table 3**  
The values of gasoline level sensor parameters using fiber coupler with one-layer, two-layer, and three-layer membrane.

Parameters	Gasoline level sensor with					
	One-layer membrane		Two-layer membrane		Three-layer membrane	
	Emptying the tank	Filling the tank	Emptying the tank	Filling the tank	Emptying the tank	Filling the tank
Dynamic range (cm)	180	180	180	180	180	180
Resolution (cm)	0.6	0.6	1.1	1.1	0.8	0.8
Linear region (cm)	100–140	120–160	10–90	20–100	10–50	10–50
Sensitivity (mV/cm)	3.2	3.2	1.4	1.4	1.3	1.4

fiber optic displacement sensor using fiber coupler, which is safe from fire and explosion since it does not use electrical signal that contacts directly with gasoline or mechanical motion that causes fire spark.

## 5. Conclusions

Gasoline level sensor based on displacement sensor using fiber coupler can be constructed by applying the hydrostatic pressure that acts upon the reflector displacement device. The elastic modulus of membrane determines the sensor characteristic. Resolution and sensitivity calculation results show that sensor with one layer membrane has the best performance with resolution and sensitivity of 0.6 cm and 3.2 mV/cm for emptying and filling the tank process. The hysteresis data for emptying and filling the tank process yields mean difference 20%, 15%, and 8% for

one-layer membrane, two-layer membrane, and three-layer membrane, respectively.

## References

- [1] Syed Azer Reza, Nabeel A. Riza, Agile lensing-based non-contact liquid level optical sensor for extreme environments, *Opt. Commun.* 283 (2010) 3391–3397.
- [2] Chengning Yang, Shiping Chen, Guoguang Yang, Fiber optical liquid level sensor under cryogenic environment, *Sens. Actuators A* 94 (2001) 69–75.
- [3] Kyung-Rak Sohn, Joon-Hwan Shim, Liquid-level monitoring sensor systems using fiber Bragg grating embedded in cantilever, *Sens. Actuators A* 152 (2009) 248–251.
- [4] M. Lomer, J. Arrue, C. Jauregui, P. Aiestaran, J. Zubia, J.M. Lopez-Higuera, Lateral polishing of bends in plastic optical fibres applied to a multipoint liquid-level measurement sensor, *Sens. Actuators A* 137 (2007) 68–73.
- [5] Samian, Yono Hadi Pramono, Ali Yunus Rohedi, Febdian Rusydi, A.H. Zaidan, Theoretical and experimental study of fiber-optic displacement sensor using multimode fiber coupler, *J. Optoelectron. Biomed. Mater.* 1 (3) (2009) 303–308.



# Gasoline level sensor based on displacement sensor using fiber coupler.

## ORIGINALITY REPORT

9%

SIMILARITY INDEX

7%

INTERNET SOURCES

4%

PUBLICATIONS

0%

STUDENT PAPERS

## PRIMARY SOURCES

1	<a href="http://www.protein-kinase-c.com">www.protein-kinase-c.com</a> Internet Source	4%
2	Samian, A. H. Zaidan, M. P. Anggraeni, M. Yasin, Supadi. "Non-touch detection of rhodamine B concentration in distilled water using fiber coupler based on displacement sensor", Microwave and Optical Technology Letters, 2018 Publication	2%
3	<a href="http://www.ugr.es">www.ugr.es</a> Internet Source	1%
4	<a href="http://www.chalcogen.ro">www.chalcogen.ro</a> Internet Source	1%
5	<a href="http://www.dtic.mil">www.dtic.mil</a> Internet Source	1%
6	<a href="http://es.scribd.com">es.scribd.com</a> Internet Source	<1%
7	Yu Zhao, Yongxing Jin, Jianfeng Wang, Xinyong Dong. "Detection of liquid-level variation using a SMS fiber structure", Optik -	<1%

# International Journal for Light and Electron Optics, 2013

Publication

---

---

Exclude quotes      Off

Exclude matches      < 10 words

Exclude bibliography      On

# Gasoline level sensor based on displacement sensor using fiber coupler.

---

## GRADEMARK REPORT

---

FINAL GRADE

**/0**

GENERAL COMMENTS

**Instructor**

---

PAGE 1

---

PAGE 2

---

PAGE 3

---

PAGE 4

---

PAGE 5

---

PAGE 6

---

PAGE 7

---