

AIP Conference Proceedings

BUY PRINT BOOKS

HOME BROWSE INFO FOR AUTHORS FOR ORGANIZERS

SIGN UP FOR ALERTS

Organizing a conference?

Enjoy fast, cost-effective publication of your meeting's key research!

AIP Conference Proceedings report findings presented at many of the most important scientific meetings around the world. Published proceedings are valuable as topical status reports providing quick access to information before it appears in the traditional journal literature.

Today, *AIP Conference Proceedings* contain over 100,000 articles published in 1,900+ proceedings, and is growing by 100 volumes every year. This substantial body of scientific literature is testament to our 40-year history as a world-class publishing partner, recognized internationally and trusted by conference organizers world-wide. Whether you are planning a small specialist workshop or organizing the largest international conference contact us, or [read these testimonials](#), to find out why so many organizers publish with *AIP Conference Proceedings*.

FORTHCOMING TITLES

For more information regarding our schedule of forthcoming proceedings

[SEE MORE](#)

• Most Recent

DEC 15 2017

Preface: The 32nd International Conference of the Polymer Processing Society

Maazouz et al.

DEC 15 2017

Committee Sponsors: The 32nd International Conference of the Polymer Processing Society

Maazouz et al.

DEC 15 2017

Optimization of the IR-heating phase in thermoforming of thermoplastic sheets:

Characterization and modelling
Buffel et al.
and
Maazouz et al.

DEC 15 2017

Polymer - Carbon nanotube composites for thermoelectric applications

Luo et al.
and
Maazouz et al.

DEC 15 2017

Fiber length reduction during shearing in polymer processing

Moritzer et al.
and
Maazouz et al.

DEC 15 2017

Determination of the optimum coupling agent content for composites based on hemp and high density polyethylene

Rodrigue et al.
and
Maazouz et al.

DEC 15 2017

Rheology and physical characterization of graphene nanoplatelet/poly (butylene adipate-co-terephthalate) nanocomposites

Kashi et al.
and
Maazouz et al.

DEC 15 2017

Optimization and modelling of delignification process for nanocrystalline cellulose production from rice husk biomass

Islam et al.
and
Maazouz et al.

• Most Read

APR 13 2016

Green synthesis of nanoparticles: Their advantages and disadvantages

AUG 12 2016

Relative importance index (RII) in ranking of procrastination factors among university students

JAN 13 2017

Cesium pentazolate: A new nitrogen-rich energetic material

• Active Topics

General physics

Materials science

Condensed matter physics

Optics and optical physics

[Browse All Topics](#)



AIP Conference Proceedings

HOME

BROWSE

MORE ▾

• Table of Contents

5TH INTERNATIONAL CONFERENCE AND WORKSHOP ON BASIC AND APPLIED SCIENCES (ICOWOBAS 2015)

< PREV NEXT >



Conference date: 16-17 October 2015
 Location: Surabaya, Indonesia
 ISBN: 978-0-7354-1364-1
 Editors: Moh. Yasin and Sulaiman W. Harun
 Volume number: 1718
 Published: Mar 15, 2016

DISPLAY : 20 50 100 all

PRELIMINARY

March 2016

Preface: 5th International Conference and Workshop on Basic and Applied Sciences (5th ICOWOBAS) 2015

AIP Conference Proceedings **1718**, 010001 (2016); <https://doi.org/10.1063/1.4943308>

⋮

March 2016

Committees: 5th International Conference and Workshop on Basic and Applied Sciences (5th ICOWOBAS) 2015

AIP Conference Proceedings **1718**, 010002 (2016); <https://doi.org/10.1063/1.4943309>

⋮

INVITED SPEAKER

March 2016

Microstructure and mechanical changes induced by Q-Switched pulse laser on human enamel with aim of caries prevention

R. Apsari, D. A. Pratomo, D. Hikmawati, and N. Bidin

AIP Conference Proceedings **1718**, 020001 (2016); <https://doi.org/10.1063/1.4943310>

SHOW ABSTRACT



BIODIVERSITY

March 2016

Sea cucumber species identification of family Caudinidae from Surabaya based on morphological and mitochondrial DNA evidence

Muhammad Hilman Fu'adil Amin, Ida Bagus Rai Pidada, Sugiharto, Johan Nuari Widyatmoko [more...](#)

AIP Conference Proceedings **1718**, 030001 (2016); <https://doi.org/10.1063/1.4943311>

SHOW ABSTRACT



March 2016

Oil removal from petroleum sludge using bacterial culture with molasses substrate at temperature variation

Ni'matuzahroh, Alvin Oktaviana Puspitasari, Intan Ayu Pratiwi, Fatimah [more...](#)

AIP Conference Proceedings **1718**, 030002 (2016); <https://doi.org/10.1063/1.4943312>

SHOW ABSTRACT



MICROBIAL BIOCHEMISTRY AND MOLECULAR BIOLOGY

March 2016

Immunofluorescence assay method to detect dengue virus in Paniai-Papua

Teguh Hari Sucipto, Nur Laila Fitriati Ahwanah, Siti Churrotin, Norifumi Mataka [more...](#)

AIP Conference Proceedings **1718**, 040001 (2016); <https://doi.org/10.1063/1.4943313>

SHOW ABSTRACT



March 2016

Inhibitor candidates's identification of HCV's RNA polymerase NS5B using virtual screening against iPPI-librarv

[BROWSE VOLUMES](#)

SHOW ABSTRACT



PHYSICS AND RENEWABLE ENERGY

March 2016

The effect of nitrogen on biogas flame propagation characteristic in premix combustion

Willyanto Anggono, Fandi D. Suprianto, Tan Ivan Hartanto, Kenny Purnomo [more...](#)

AIP Conference Proceedings **1718**, 100001 (2016); <https://doi.org/10.1063/1.4943345>

SHOW ABSTRACT



March 2016

Porous carbon materials synthesized using IRMOF-3 and furfuryl alcohol as precursor

Pemta Tia Deka, and Ratna Ediaty

AIP Conference Proceedings **1718**, 100002 (2016); <https://doi.org/10.1063/1.4943346>

SHOW ABSTRACT



March 2016

Fiber optic displacement sensor for medal detection using fiber bundled probe

M. Yasin, Samian, Supadi, Pujiyanto [more...](#)

AIP Conference Proceedings **1718**, 100003 (2016); <https://doi.org/10.1063/1.4943347>

SHOW ABSTRACT



STATISTICS, PURE AND APPLIED MATHEMATICS

Open . March 2016

Estimation of median growth curves for children up two years old based on biresponse local linear estimator

Nur Chamidah, and Marisa Rifada

AIP Conference Proceedings **1718**, 110001 (2016); <https://doi.org/10.1063/1.4943348>

SHOW ABSTRACT



March 2016

AIP Conference Proceedings

47

H Index

Country	United States
Subject Area and Category	Physics and Astronomy Physics and Astronomy (miscellaneous)
Publisher	
Publication type	Conferences and Proceedings
ISSN	0094243X
Coverage	1983-1984, 2005-ongoing
Scope	AIP Conference Proceedings report findings presented at many of the most important scientific meetings around the world. Published proceedings are valuable as topical status reports providing quick access to information before it appears in the traditional journal literature. (source)

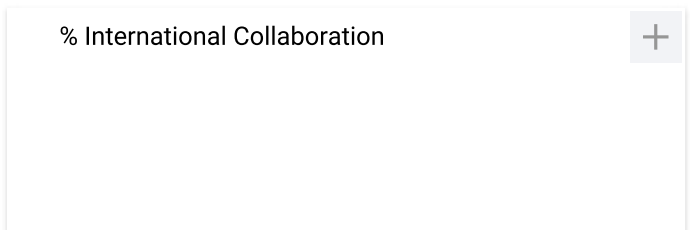
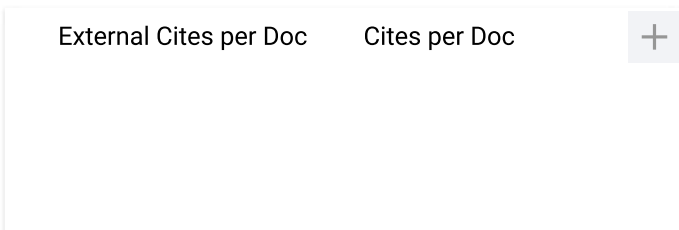
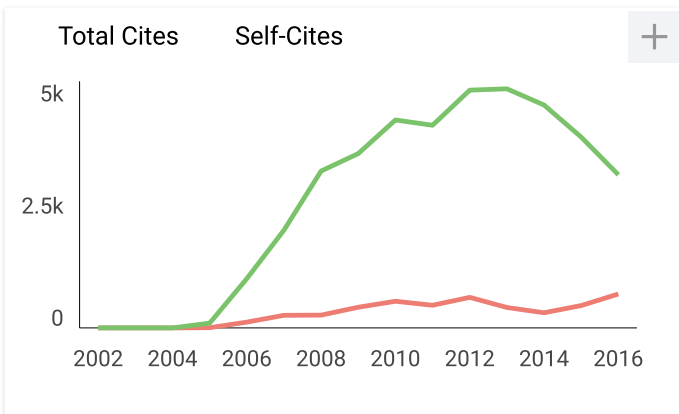
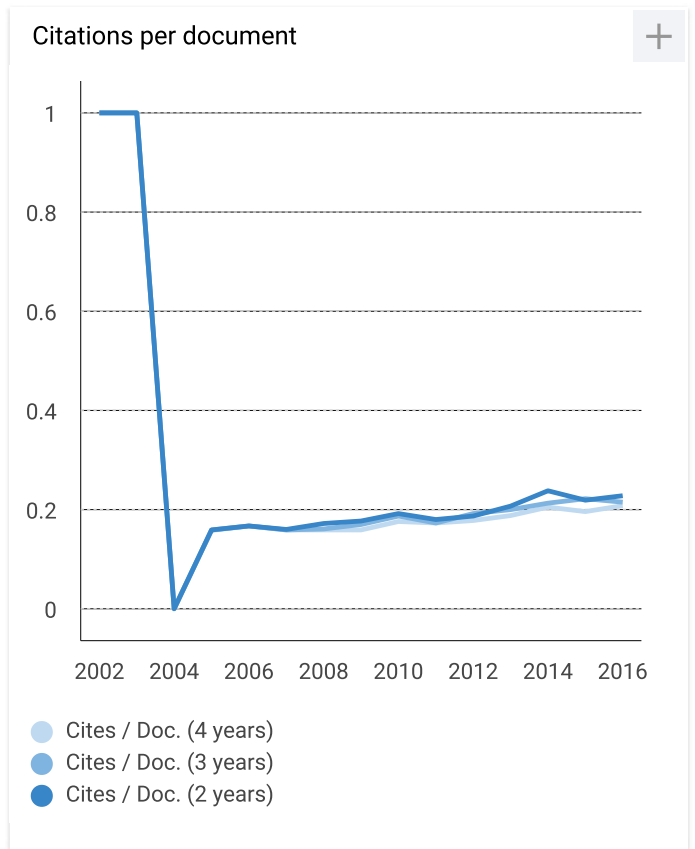
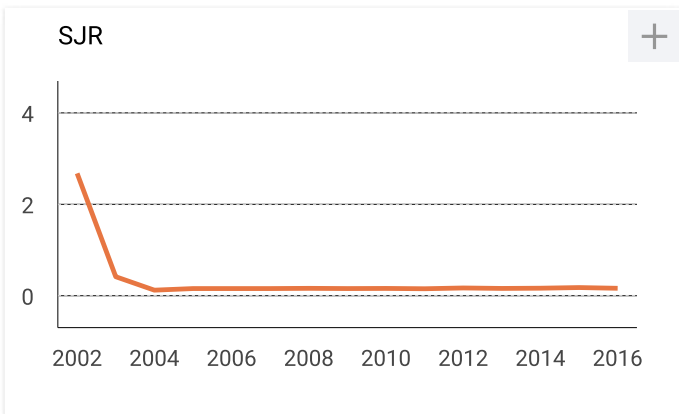

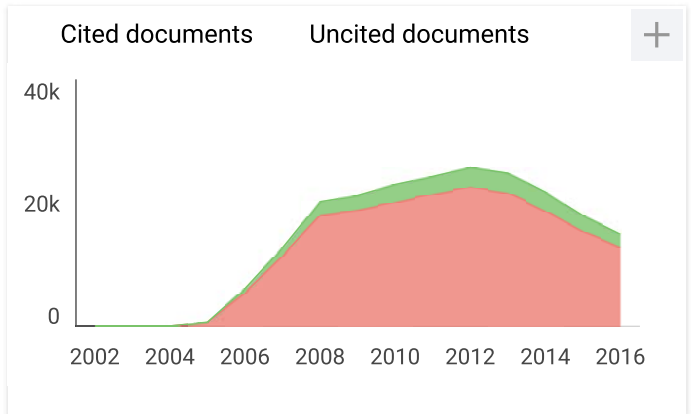
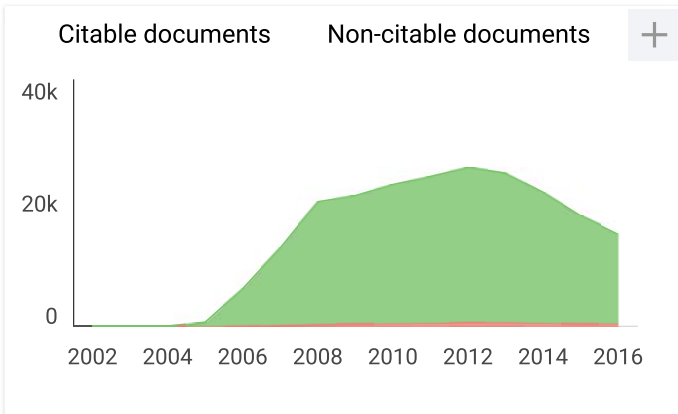
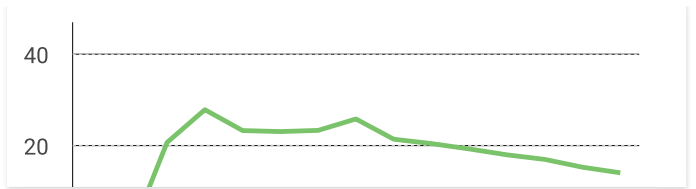

AIP Conference Proceedings ← Show this widget in your own website

Indicator	2009-2016	Value
SJR		0.16
Cites per doc		0.23
Total cites		3104

Just copy the code below and paste within your html code:

```
<a href="http://www.scimagr
```

www.scimagojr.com

Developed by:



Powered by:



Follow us on Twitter

Scimago Lab, Copyright 2007-2017. Data Source: Scopus®

EST MODUS IN REBUS
Horatio (Satire 1,1,106)



Fiber optic displacement sensor for medal detection using fiber bundled probe

M. Yasin, Samian, Supadi, Pujiyanto, and Y. G. Yhun Yhuwana

Citation: [AIP Conference Proceedings](#) **1718**, 100003 (2016); doi: 10.1063/1.4943347

View online: <http://dx.doi.org/10.1063/1.4943347>

View Table of Contents: <http://scitation.aip.org/content/aip/proceeding/aipcp/1718?ver=pdfcov>

Published by the [AIP Publishing](#)

Articles you may be interested in

[Fiber optic displacement sensor using a coated lens optic](#)

Rev. Sci. Instrum. **71**, 4314 (2000); 10.1063/1.1290498

[Characterization of an optical fiber bundle sensor](#)

Rev. Sci. Instrum. **69**, 1985 (1998); 10.1063/1.1148885

[Fiber optic multimode displacement sensor](#)

AIP Conf. Proc. **368**, 248 (1996); 10.1063/1.50340

[Fiber optic angular displacement sensor](#)

Rev. Sci. Instrum. **66**, 3672 (1995); 10.1063/1.1145486

[Force microscope using a fiber-optic displacement sensor](#)

Rev. Sci. Instrum. **59**, 2337 (1988); 10.1063/1.1139958

Fiber Optic Displacement Sensor for Medal Detection using Fiber Bundled Probe

M. Yasin^{1*}, Samian¹, Supadi¹, Pujiyanto¹ and Y.G. Yhun Yhuwana¹.

¹*Department of Physics, Faculty of Science and Technology, Airlangga University, Surabaya 60115, Indonesia.*

**Email: yasin@fst.unair.ac.id*

Abstract: A simple fiber optic displacement sensor (FODS) based on intensity modulation technique is investigated using a bundle multimode plastic fiber as a probe for various medals detection. The sensor consists of a light source, a probe, and photodiode detector. The sensor is capable of measuring displacements of flat medals ranging from 0.05 to 4.2 mm using a red light source of wavelength 630 nm. The highest sensitivity of the sensor is found to be 0.0048 mV/ μm over 50-650 μm for the gold medal. The sensor is highly sensitive at the front slope and very useful for close distance target. The simplicity of the design, high sensitivity, long dynamic range and the low cost of the fabrication make it suitable for wider applications in industries as position control and micro displacement measurement in the hazardous region.

Keywords: fiber optic, fiber displacement sensor, medal detection, reflection based.

INTRODUCTION:

Fiber optic displacement sensor (FODS) has wide application, because its work based on variable range of parameters such as, temperature, compression, pressure and strain [1,2]. FODS offer several advantages over conventional sensor systems. Specifically due to its non-contact and non-electric, compact, lightweight, sensitivity, immune to electromagnetic interference, and distributed sensing over the lengths of fiber optic. Inherently it is a versatile sensor which allows operating in dangerous environment such as in chemical reaction or explosive region [3,4], but less attention is focused to use optical technology to test the purity of metal especially noble metal like gold.

The medals (gold, silver and bronze) are a valuable metal because they are chemically inert, which used in many devices as coating, gold nanoparticle for commercially as jewelry. All these applications normally required high purity of gold. Thus determination purity of gold (medal) is important to ensure the functionality of the device, the successful of the treatment or satisfaction of the consumer. Currently several methods to determine the medals purity or karats are available. In conventional method, analysis of a metal-bearing material, especially medals and silver was carried out using fire assay that is heated the sample with a suitable flux and weighing the resulting metal beads. This is the common practices in all jewellery shop. They are time consuming, cumbersome as well as destructive.

Chemical analysis normally involves acid solution to verify the purity of medals with a degree of certainty. However safety handling of acid is required [5]. Other method by using sophisticated machine like x-ray fluorescent (XRF) and specific gravity based measurement device to detect the purity of medals. Although XRF testing is the most accurate medals purity testing technique, and also non-destructive testing, but it is high cost testing and time consuming making it less compatible for testing in small scale samples [6-8]. In this research, we proposed a novel method of measuring purity of medals based on fiber optic displacement sensor using intensity modulation

technique. The proposed system consist of a fiber probe, a red laser (630 nm), photodetector and translation stage to provide highly accurate with 10 μm of resolution.

EXPERIMENTAL SETUP

Figure 1 shows the schematic diagram of the fiber optic displacement sensor by using fiber probe with 1000 RF. The experimental setup consists of a light source, a bundled fiber optic probe, flat medals (e.g. gold, silver and bronze), a silicon photo-detector and a digital multimeter. A bundled fiber optic probe was used, the glass fiber probe with 1000 TF (= 0.05 mm) and 1000 RF (= 0.05 mm). The light source used is a He-Ne laser with a peak wavelength of 630 nm. Silicon photo-detector was employed as it provides precision detection with an wavelength response of 400-1100 nm, making it compatible with a wide range of visible light including the 630 nm visible He-Ne laser used in this experiment.

The displacement of the fiber optic probe from the flat medals, is varied by mounting it on a micrometer translation stage, which was rigidly attached to a vibration free table. The light from He-Ne laser enters the transmitting fiber (TF) and then radiates to the flat medal, and the light reflected from the medal is transmitted through the receiving fiber (RF) bundle to silicon photo-detector. The amount of light detected by the photodetector can be determined from the output signal from the detector which has been preliminary connected to a digital multimeter. The voltage is measured against the corresponding change in displacement of micrometer translation stage. All samples used were obtained from commercial medals. The sensor utilizes the linear parameters from each pattern of output signal against displacement recorded for each target as the linear calibration slope.

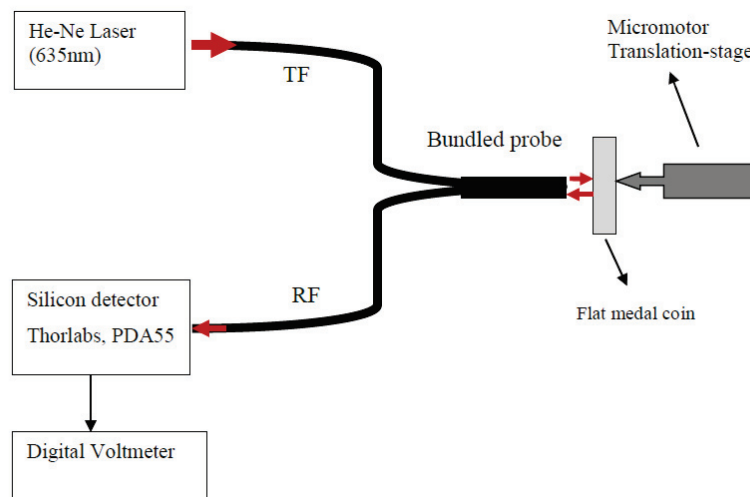

Figure 1: Experimental setup of fiber optic displacement for flat medal plate detection

RESULTS AND DISCUSSIONS:

Figure 2 shows the variation of the output voltage of the sensor with the displacement of the flat medals from the fiber optic probe. The curve exhibits a maximum with a steep front slope and back slope which obeys an almost inverse square law relationship for the reflected light intensity versus distance of the flat medals from fiber optic probe. The signal is very low at zero distance because the light cone does not reach the receiving cores. When the displacement is increased, the size of the reflected cone of light at the plane of fiber increases and starts overlapping with the receiving cores leading to a small output voltage. Further increase in the displacement leads to large overlapping which results in increase in output voltage. However, after reaching maximum, the output voltage starts decreasing for larger displacements. This is because of large increase in the size of the light cone and the power density decreases with increase in the size of the cone of light. The maximum output voltage obtained is 3.3 mV for a distance of 1.0 mm between the flat medals and the fiber optic probe.

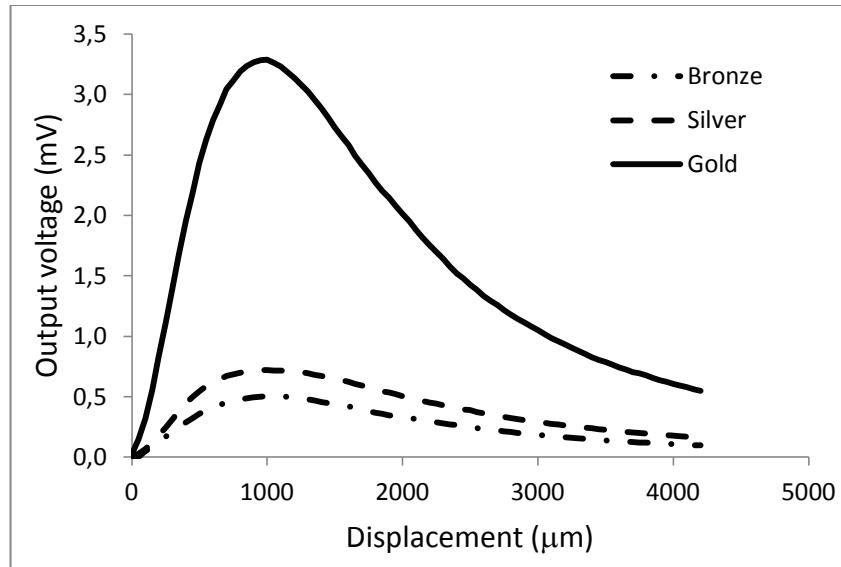

Figure 2: Output voltage of the sensor versus displacement for various medals.

Figure 3 shows the linear range of the sensor for gold medal for front and back slope. The slope is used to determine sensitivity of the sensor. As shown in the figure, the sensor achieves the highest sensitivity of $0.005 \text{ mV}/\mu\text{m}$ over the range of $0.05\text{--}0.65 \text{ mm}$. Sensitivity of $-0.00132 \text{ mV}/\mu\text{m}$ is also achieved over a range $1.3\text{--}2.6 \text{ mm}$. The sensor shows a very good linearity for the gold medal in both ranges as shown in Figure 3. However, the graph exhibits the nonlinear properties over a range of $0.80\text{--}1.20 \text{ mm}$. In our displacement sensor, the front slope is highly sensitive and useful for close distance target and the back slope is less sensitive and useful for long distance. The performance of the sensor is summarized in Table 1. The sensor has many potential applications such as in industries as monitoring automated control, position control, and micro-displacement sensor in the hazardous regions. New, robust, low cost yet very sensitive gold sensor is proposed utilizing fiber optic displacement sensor. Based on the standard provide by the optical sensor, any unknown purity of medals plate can be determined. This optical sensor is very beneficial for quality control in mass production of solid medals such as in the form of foil, coin, and bar.

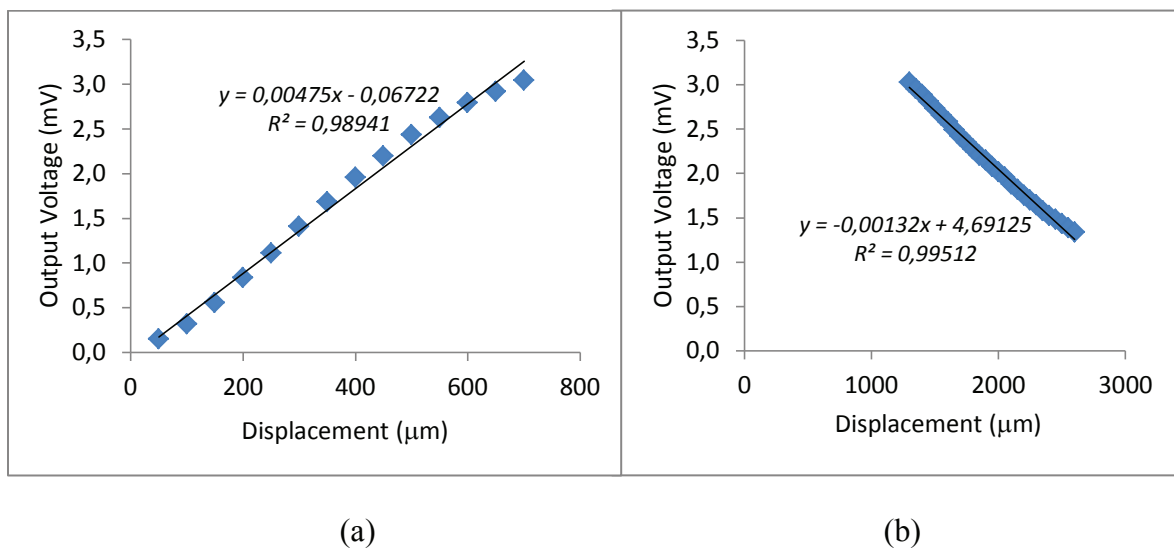

Figure 3: The linear range of gold medal for (a) front slope and (b) back slope.

Table 1: Performance of FODS for medals detection.

Medals	Front slope		Back slope	
	Linear range (μm)	Sensitivity ($\text{mV}/\mu\text{m}$)	Linear range (μm)	Sensitivity ($\text{mV}/\mu\text{m}$)
Gold	600 (50-650)	0.0048	1300 (1300-2600)	0.00132
Silver	650 (50-700)	0.0011	1550 (1330-2850)	0.00025
Bronze	500 (50-650)	0.0007	1350 (1250-2600)	0.00019

CONCLUSION:

A simple fiber optic displacement sensor is proposed based on intensity modulation technique to detect the purity of various flat medals. The sensor uses a bundled fiber probe (1000 RF) and the red laser of peak wavelength 630 nm as a light source. The sensor shows a very good linearity (more than 99%) with the highest sensitivity of 0.0048 $\text{mV}/\mu\text{m}$ over a range of 0.05– 0.65 mm for the gold medal. Instead of using high cost instrument such as XRF, this sensor offers an equivalent replacement with its simplicity and low cost. In future, further improvement can be done on this system to provide detection of the purity of medals in the form of nanoparticles that is used widely for medical purposes.

ACKNOWLEDGMENT:

The authors like to express thank to Prof. Noriah Bidin and Dr. M. Abdullah (Advanced Photonic and Science Institute), Universiti Teknologi Malaysia, Malaysia for collaboratios and discussions.

REFERENCES:

1. Wang Wei, Shi Xiaotian, Wang Ying, *Sapphire Fiber-Optic Temperature Sensor Based on Black-Body Radiation Law*, *Procedia Engineering* **99**, pp. 1179 – 1184, 2015.
2. S. Revathi, Srinivasa Rao Inabathini, Jatin Pal, *Pressure and Temperature Sensor Based on a Dual Core Photonic Quasi-Crystal Fiber*, *Optik - International Journal for Light and Electron Optics*, doi: doi:10.1016/j.ijleo.2015.07.141., Available online 31 July 2015.
3. S. S. Patil, P. Buchade, and A. Shaligram, *Refractometric Fiber Optic Adulteration level detector for Diesel*, *Sensors and Actuators A: Physical* **201**, pp. 79-85, 2013.
4. M. Chaplan. *The Urban Treasure Hunter: A Practical Handbook for Beginners*. Square One Publishers, Inc., 2003.
5. M. Yasin, S. W. Harun, H. A. Abdul-Rashid, Kusminarto, Karyono, A. H. Zaidan, H. Ahmad, Performance of optical displacement sensor using a pair type bundled fiber from a theoretical and experimental perspective, *Optoelectronics and Advanced Materials-Rapid Comm.*, Vol. 1, No. 11, 2007.
6. Andrew Turner, Sean Comber, Aldous B. Rees, Dimitrios Gkiokas, Kevin Solman, *Metals in boat paint fragments from slipways, repair facilities and abandoned vessels: An evaluation using field portable XRF*, *Talanta* **131**, pp. 372-378, 2015.
7. Khalid Saleh Ali Aldroobi, A. Shukri, SabarBauk, Eid Mahmoud Abdel Munem, Ali.M.A. Abuarra, *Determination of arsenic and mercury level in scalp hair from a selected population in Penang, Malaysia using XRF technique*, *Radiation Physics and Chemistry*, Volume **91**, pp. 9–14, 2013.
8. M. Robertson and C. Feather., *An automated energy-dispersive x-ray fluorescence spectrometer*, *X-Ray Spectrometry* **33** (164), 2004.