

See discussions, stats, and author profiles for this publication at: <https://www.researchgate.net/publication/354079964>

Hypoxic preconditioning promotes survival of human adipocyte mesenchymal stem cell via expression of prosurvival and proangiogenic biomarkers

Article in *F1000 Research* · August 2021

DOI: 10.12688/f1000research.55351.1

CITATIONS

0

READS

27

5 authors, including:



I Gde RURUS Suryawan

Dr Soetomo General Hospital

21 PUBLICATIONS 32 CITATIONS

[SEE PROFILE](#)



Ricardo Adrian Nugraha

Airlangga University

53 PUBLICATIONS 18 CITATIONS

[SEE PROFILE](#)

Some of the authors of this publication are also working on these related projects:



NEPHROLOGY AND HYPERTENSION - Complication of Kidney Diseases [View project](#)



DIABETES CARDIOVASCULAR COMPLICATION - Intensive vs Standard Glucose Lowering Treatment: Safety and Benefit [View project](#)



RESEARCH ARTICLE

Hypoxic preconditioning promotes survival of human adipocyte mesenchymal stem cell via expression of prosurvival and proangiogenic biomarkers [version 1; peer review: awaiting peer review]

I Gde Rurus Suryawan¹, Budi Susetyo Pikir¹, Fedik Abdul Rantam², Anudya Kartika Ratri¹, Ricardo Adrian Nugraha¹

¹Cardiology and Vascular Medicine, Universitas Airlangga, Surabaya, East Java, 60286, Indonesia

²Virology and Immunology, Faculty of Veterinary Medicine, Universitas Airlangga, Surabaya, East Java, 60286, Indonesia

V1 First published: 23 Aug 2021, 10:843
<https://doi.org/10.12688/f1000research.55351.1>
Latest published: 23 Aug 2021, 10:843
<https://doi.org/10.12688/f1000research.55351.1>

Abstract

Background: Contributing factors for improved survival of human adipocytes mesenchymal stem cells (h-AMSCs) cultured through hypoxia preconditioning, in example apoptosis inhibition involving BCL2 and HSP27 expression, trigger signal expression (VEGF), SCF expression, OCT-4 expression, and CD44+ expression. The objective if this study was to explain the mechanism and role of hypoxic preconditioning and the optimal duration of hypoxic preconditioning exposure to improve survival of h-AMSCs.

Methods: An experimental laboratory explorative study (*in vitro*) with hypoxic preconditioning in h-AMSCs cultures. This research was conducted through four stages. First, isolation of h-AMSCs culture from adipose tissue of patients. Second, the characterization of h-AMSCs from adipose tissue by phenotype (flowcytometry) through CD44+, CD90+ and CD45-expression before being pre-conditioned for hypoxic treatment. Third, the hypoxic preconditioning in h-AMSCs culture (*in vitro*) was performed with an oxygen concentration of 1% for 24, 48 and 72 hours. Fourth, observation of survival from h-AMSCs culture was tested on the role of CD44+, VEGF, SCF, OCT-4, BCL2, HSP27 with Flowcytometry and apoptotic inhibition by Tunnel Assay method.

Results: The result of regression test showed that time difference had an effect on VEGF expression ($p < 0.001$; $\beta = -0.482$) and hypoxia condition also influenced VEGF expression ($p < 0.001$; $\beta = 0.774$). The result of path analysis showed that SCF had effect on OCT-4 expression ($p < 0.001$; $\beta = 0.985$). The regression test results showed that time effects on HSP27 expression ($p < 0.001$; $\beta = 0.398$) and hypoxia precondition also affects HSP27 expression ($p < 0.001$; $\beta = 0.847$).

Open Peer Review

Reviewer Status AWAITING PEER REVIEW

Any reports and responses or comments on the article can be found at the end of the article.

Pathway analysis showed that BCL2 expression inhibited apoptosis ($p=0.030$; $\beta=-0.442$) and HSP27 expression also inhibited apoptosis ($p<0,001$; $\beta=-0.487$).

Conclusion: Hypoxic preconditioning of h-AMSC culture has proven to increase the expression of VEGF, SCF, OCT-4, and BCL2 and HSP27.

This study demonstrated and explained the existence of a new mechanism of increased h-AMSC survival in cultures with hypoxic preconditioning (O₂ 1%) via VEGF, SCF, OCT-4, BCL2, and HSP 27.

Keywords

apoptosis, h-AMSCs, BCL-2, HSP27, SCF, VEGF expression

Corresponding author: I Gde Rurus Suryawan (igde.rurus.s@fk.unair.ac.id)

Author roles: **Suryawan IGR:** Conceptualization, Data Curation, Funding Acquisition, Resources, Writing – Review & Editing; **Pikir BS:** Conceptualization, Formal Analysis, Supervision, Writing – Review & Editing; **Rantam FA:** Methodology, Project Administration, Software, Validation; **Ratri AK:** Data Curation, Investigation, Project Administration, Visualization; **Nugraha RA:** Formal Analysis, Software, Visualization, Writing – Original Draft Preparation

Competing interests: No competing interests were disclosed.

Grant information: The author(s) declared that no grants were involved in supporting this work.

Copyright: © 2021 Suryawan IGR *et al.* This is an open access article distributed under the terms of the [Creative Commons Attribution License](#), which permits unrestricted use, distribution, and reproduction in any medium, provided the original work is properly cited.

How to cite this article: Suryawan IGR, Pikir BS, Rantam FA *et al.* **Hypoxic preconditioning promotes survival of human adipocyte mesenchymal stem cell via expression of prosurvival and proangiogenic biomarkers [version 1; peer review: awaiting peer review]** F1000Research 2021, **10**:843 <https://doi.org/10.12688/f1000research.55351.1>

First published: 23 Aug 2021, **10**:843 <https://doi.org/10.12688/f1000research.55351.1>

Abbreviation

AMSC: Adipose Mesenchymal Stem Cells
 ATP: Adenosine Triphosphate
 BAX: BCL-2-associated X protein
 BCL2: B-Cell Lymphoma 2
 CD44: Cluster of Differentiation 44
 h-AMSC: human Adipose Mesenchymal Stem Cells
 HSF1: Heat Shock Factor 1
 HSP27: Heat Shock Protein 27
 ITD: Institute of Tropical Diseases (Universitas Airlangga)
 MANOVA: Multivariate Analysis of Variance
 OCT4: Octamer-binding transcription factor 4
 PK2: Protein k-2
 PKC: Protein kinase C
 ROS: Reactive oxygen species
 SCF: Stem Cell Factor
 SLF: Steel Factor
 SPSS: Statistical Package for Social Sciences
 VEGF: Vascular Endothelial Growth Factor

Introduction

Several literatures provide abundant information that human adipocytes mesenchymal stem cells (h-AMSCs) is an attractive resource for therapeutics and have beneficial effects in regenerating injured cardiomyocytes due to their self-renewal ability and broad differentiation potential under physiological and pathological conditions.¹⁻³

Despite the impressive potential of the h-AMSC-based therapy, several obstacles (e.g., the difficulty of maintaining self-renewal and poor survival due to apoptosis and/or necrosis at the administration site) have been encountered.⁴ Some studies suggest that more than 90% of transplanted stem cells, either intravenously, intramyocardially, and intracoronary delivery, have necrosis and apoptosis and only about 5% transplanted stem cells can survive up to 14 days in infarcted myocardium.⁵ The survival of stem cells transplantation is so poor because high percentage of dead cells due to factors such as limited availability of blood, hypoxia, oxidative stress, inflammatory processes, loss of extracellular cell buffer matrix (anoic), non-conductive microenvironment to myocardial infarction, structural damage to blood vessels and lack of nutritional support.⁶

Therefore a particular strategy is needed to improve survival, increase proliferation, migration, maintain the potential for differentiation and viability of stem cells in environments with low oxygen levels. One of those strategies is to precondition hypoxic precursors *in vitro* on oxygen concentrations mimicking the stem cells' niche.^{7,8} Contributing factors for improved survival of h-AMSCs cultured through hypoxia preconditioning, i.e., apoptosis inhibition involving BCL2 and HSP27 expression, trigger signal expression (VEGF), SCF expression, OCT-4 expression, and CD44 + expression.⁹

In detail, it has never been explained how far the role of hypoxic preconditions in inhibiting apoptosis of h-AMSCs culture *in vitro*, in order to enhance survival and increase proliferation, maintain multi-potency, stemness and inhibition of apoptosis. Based on the description above, we consider it is necessary to conduct a research to explain the increased survival of h-AMSCs through the treatment of sub-lethal hypoxia precondition (oxygen concentration of 1%) for 24, 48, and 72 hours by looking at the expression of inhibition on apoptosis and HSP27 expression, and BCL2. In addition, it is necessary to observe the role of hypoxic preconditions in the proliferation process through the expression of SCF, OCT-4, and BCL2.

Objective

A study was conducted to explain and confirm the mechanism and role of hypoxic preconditioning and the optimal duration of hypoxic preconditioning exposure to improve survival of h-AMSCs so that it could be used as a benchmark for h-AMSCs culture strategy before transplantation. This study was an experimental laboratory explorative study (*in vitro* study) with hypoxic preconditioning in human-adipose mesenchymal stem cells (h-AMSCs) cultures.

Methods

Ethical approval

The use of human subjects in this study had been obtaining an ethical approval from research ethics committee of Dr. Soetomo Academic General Hospital - Faculty of Medicine, Airlangga University (Number: 264/Panke.KKE/IV/2017) issued on April 6th, 2017 under the name of I Gde Rurus Suryawan as principal investigator.

Study design

This study is an exploratory laboratory experimental study (*in-vitro* study) with hypoxic preconditions in the culture of human-adipose mesenchymal stem cells (h-AMSCs) derived from human adipose tissue. The aim of this study was to obtain stem cells that have high survival so that they are not only viable but also have high adaptability to the environment when the stem cells are transplanted. This type of experiment is a true experimental post-test only control group design accompanied by phenotypic h-AMSCs characterization against CD44+, CD90 + and CD45- before being given treatment.

Study setting

This research was conducted at the Center for Research and Development of Stem Cell - Institute Tropical Disease (ITD) Universitas Airlangga, Dr. Soetomo Academic General Hospital and the Faculty of Medicine, Airlangga University, Surabaya. The implementation of this study lasted for 2-3 months.

Sample size

The sample size in this study was obtained using the Federer's formula for sample size.¹⁰ This formula is used as a control for the degree of freedom in MANOVA. The formula description is as follows:

Sample size: $(r-1)(K-1) \geq 15$

r = replication (experimental unit sample size per group)

K = number of subject group observations

$K = 6$

$(r-1)(K-1) \geq 15$

$(r-1)(6-1) \geq 15$

$(r-1)5 \geq 15$

$r-1 \geq 3$

$r = 4$

Then the number of replications for each group is 4, so that the total sample is 24 plate culture.

Materials

Experimental Unit:

1. h-AMSCs, namely human-adipose mesenchymal stem cells from adipose tissue obtained from minimally invasive surgery with small incisions (3-5 cm) under local anaesthesia in the lower abdominal area by a surgeon (Figure 1). These materials came from patients who were prepared for clinical application of stem cell therapy at the Network Bank Dr. Soetomo General Hospital, Surabaya. All procedures were approved by the relevant ethics committees, and written informed consent was obtained from all study participants. The h-AMSCs experimental unit was taken from adult patients who were in a stable state who were not taking anti-platelets or anti-coagulants and then multiplied *in vitro* at the 5th passage to 24 units. A total of 24 units were divided into two groups, namely control and treatment. The control group (P0) had 12 culture units in normoxic conditions (21% O₂ concentration). The treatment group (P1) was 12 units pre-conditioned to hypoxia (1% O₂ concentration). Both treatment groups were observed for survival (CD44+, VEGF, SCF, OCT-4, BCL2, HSP27, and apoptotic inhibition at 24, 48 and 72 hours of cell culture). Observation of apoptotic inhibition based on the expression of BCL2 and HSP27 along with the percentage of apoptosis that occurred.
2. Washing buffer (phosphate-buffered saline, PBS, Sigma-Aldrich, Milan, Italy, 0.1% sodium azide, and 0.5% bovine serum albumin (BSA), Radnor, USA) was used for all washing steps (3 ml of washing buffer and centrifugation, 400g for eight minutes at 4°C). Briefly, 5×10^5 cells/sample were incubated with 100 ml of 20 mM ethylene-diaminetetraacetic acid (EDTA, Sigma-Aldrich) at 37°C for 10 minutes and washed.

Experimental procedures

This research was conducted in four stages as follows:

1. Isolation and culture of h-AMSCs from the patient's adipose tissue (human) (Figure 1).

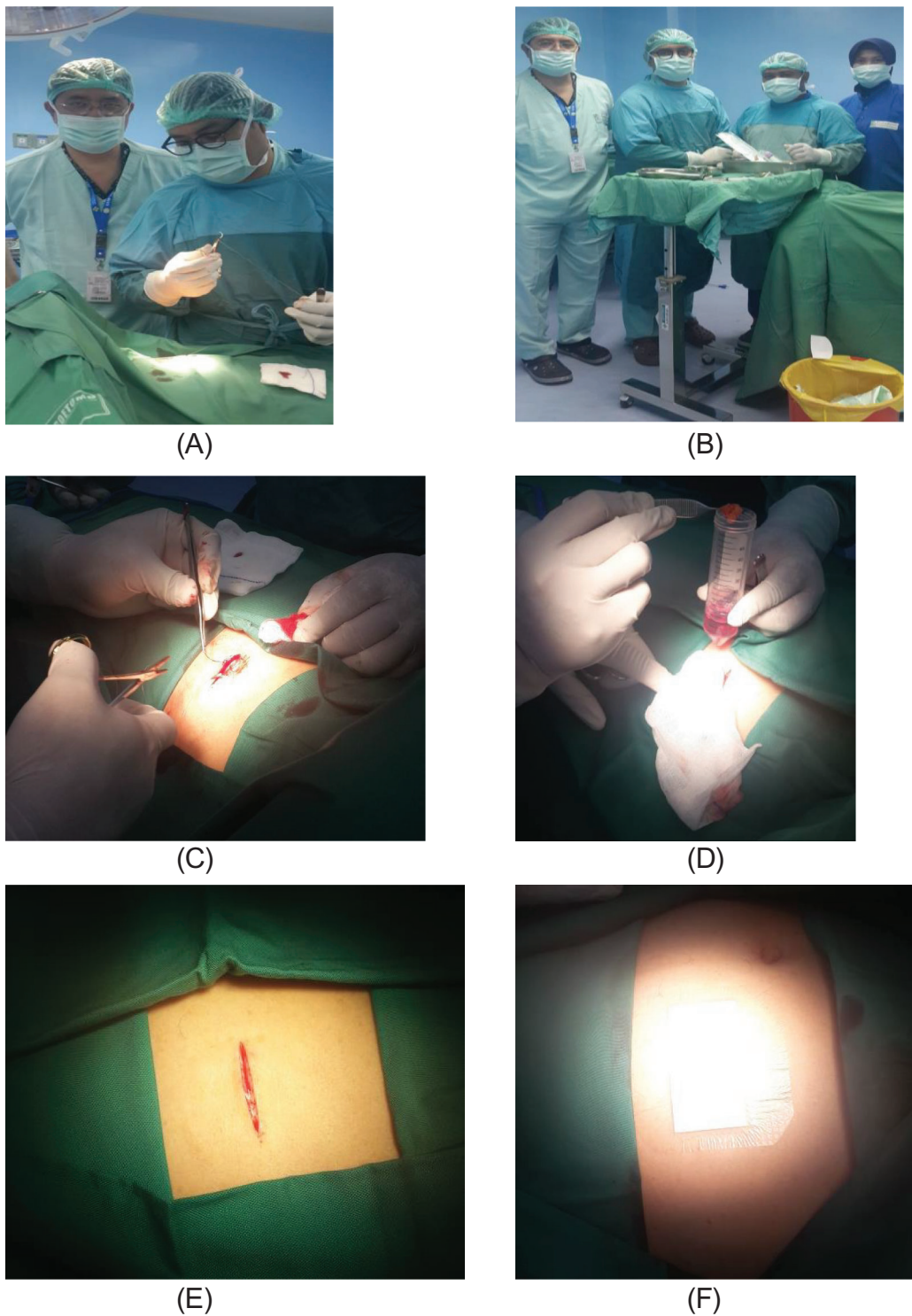
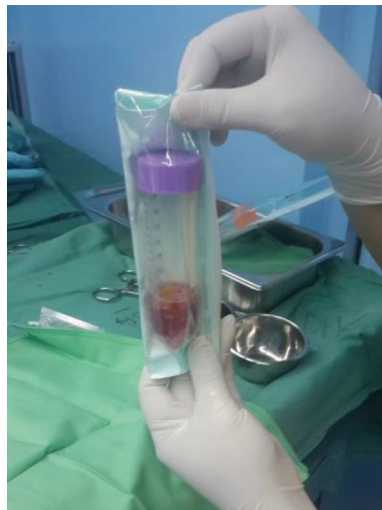

Figure 1. Isolation and culture of h-AMSCs from the patient's adipose tissue (human).

2. Characterization of h-AMSCs from adipose tissue phenotypically (Flowcytometry) through identification of CD44+, CD90+ and CD45- before being treated with hypoxic preconditions.
3. Hypoxic precondition in *in vitro* h-AMSCs culture was carried out with an oxygen concentration of 1% for 24, 48 and 72 hours.
4. Observation of survival of h-AMSCs in the form of CD44 +, VEGF, SCF, OCT-4, BCL2, HSP27 expression, and apoptotic inhibition:

- a. Phenotype expression of CD44 + was carried out by the flowcytometric method.
- b. Immuno-cytochemical expression of VEGF
- c. Immunocytochemical expression of SCF from h-AMSCs culture
- d. Phenotype of OCT-4 expression (Immunocytochemistry and Immunofluorescence)
- e. Apoptotic inhibition, based on the expression of BCL2 and HSP27 by immunocytochemistry accompanied by a low percentage of apoptosis through the Tunnel Assay method (Figure 2).



(A)



(B)



(C)

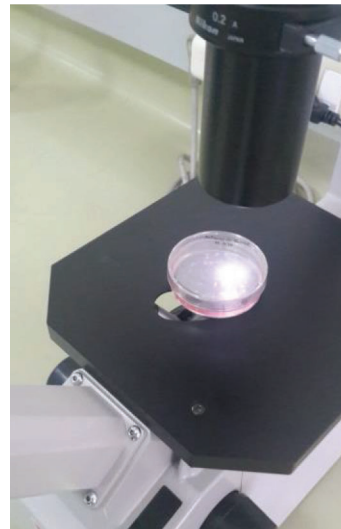

(D)

Figure 2. Observation of survival of h-AMSCs in the form of CD44 +, VEGF, SCF, OCT-4, BCL2, HSP27 expression, and apoptotic inhibition:

- A. Phenotype expression of CD44 + was carried out by the flowcytometric method.
- B. Immuno-cytochemical expression of VEGF.
- C. Immunocytochemical expression of SCF from h-AMSCs culture.
- D. Phenotype of OCT-4 expression (Immunocytochemistry and Immunofluorescence).

Table 1. Results on CD44+ expression.

Time (hour)	Experimental group	Mean ± SD	p
24	Normoxia	72.07 ± 2.985	0.149
	Hypoxia	82.42 ± 12.14	
48	Normoxia	67.61 ± 3.158	0.370
	Hypoxia	69.48 ± 2.203	
72	Normoxia	65.85 ± 1.321	0.446
	Hypoxia	67.64 ± 4.184	

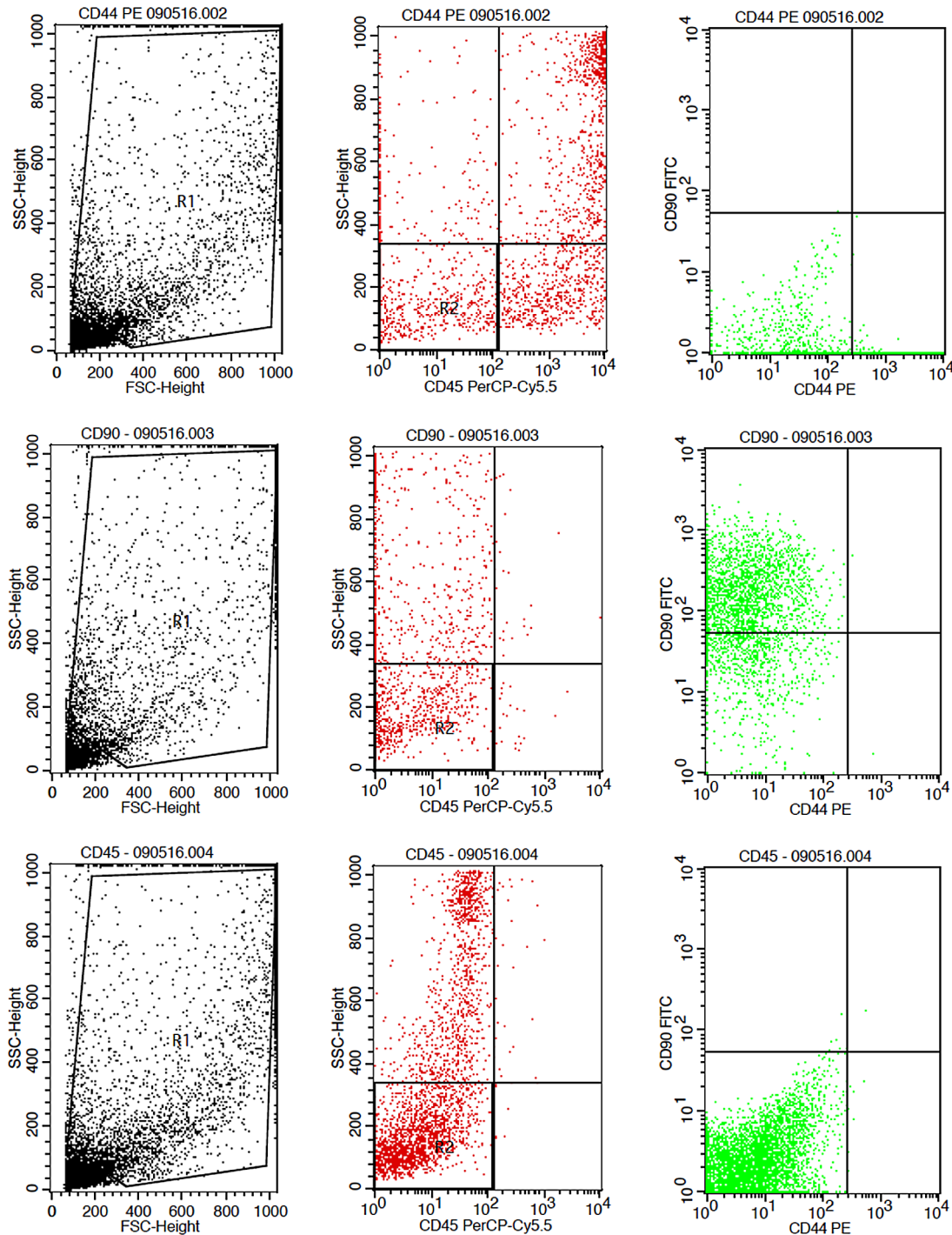

Figure 3. Flowcytometry results from human AMSCs based on cell culture for CD44+ CD90+ CD45- expression.

Data analysis

Data collected, processed and statistically tested with several stages. The first stage is an Assumption Test in the form of a normality test to ensure that the data is normally distributed. Furthermore, a comparison test was carried out between the treatment group and the control group using Multivariate Analysis of Variance (MANOVA). Furthermore, path analysis is carried out to determine the pathway mechanism of the influence of the independent variables on the dependent variable by using multiple linear regression statistical tests. The statistical analysis was used to explain the effect of time (24, 48 and 72 hours) and hypoxic conditions on the expression of VEGF, SCF, OCT-4, CD44 +, BCL2, HSP27 and the number of cells undergoing apoptosis. The data scale of each variable under study is a ratio, so it is appropriate to use the Multiple Linear Regression statistical test. Statistical tests were performed using SPSS version 24.0 software.

Results

The results showed that the time difference test on CD44+ expression was 24 hours with 48 hours ($p = 0.017$), 24 hours with 72 hours ($p = 0.004$), and 48 hours with 72 hours ($p = 0.801$). The result of regression test showed that time difference had an effect on expression of CD44 + ($p = 0.002$, $\beta = -0.582$) and hypoxia condition had no effect to CD44 + expression ($p = 0.066$, $\beta = 0,317$) (Table 1) (Figure 3).

The result of time difference test on VEGF expression is between 24 hours with 48 hours ($p < 0.001$), 24 hours with 72 hours ($p < 0.001$), and 48 hours with 72 hours ($p = 0.047$). The result of regression test showed that time difference had an effect on VEGF expression ($p < 0.001$; $\beta = -0,482$) and hypoxia condition also influenced VEGF expression ($p < 0.001$; $\beta = 0,774$) (Table 2) (Figure 4).

Table 2. Results on VEGF expression.

Time (hour)	Experimental group	Mean \pm SD	p
24	Normoxia	0.175 \pm 0.074	0.000
	Hypoxia	0.766 \pm 0.123	
48	Normoxia	0.103 \pm 0.018	0.000
	Hypoxia	0.425 \pm 0.036	
72	Normoxia	0.075 \pm 0.014	0.000
	Hypoxia	0.291 \pm 0.033	

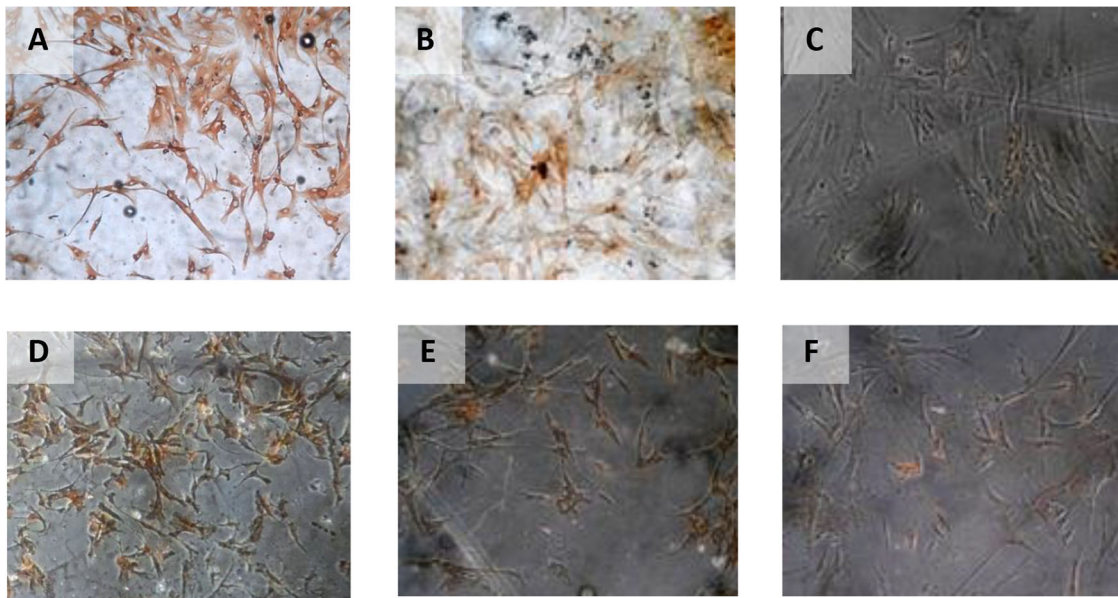

Figure 4. Immunohistochemical Characteristic of h-AMSCs based on VEGF expression at: A) normoxic condition for 24 hours; B) normoxic condition for 48 hours; C) normoxic condition for 72 hours; D) hypoxic condition for 24 hours; E) hypoxic condition for 48 hours; F) hypoxic condition for 72 hours.

The result of time difference test on SCF expression is between 24 hours with 48 hours ($p = 0.283$), 24 hours with 72 hours ($p < 0.001$), and 48 hours with 72 hours ($p < 0.001$). The result of path analysis showed that VEGF influenced the expression of SCF ($p < 0.001$; $\beta = 0.889$) (Table 3) (Figure 5).

The result of time difference test on OCT-4 expression is between 24 hours with 48 hours ($p < 0.001$), 24 hours with 72 hours ($p < 0.001$), and 48 hours with 72 hours ($p < 0.001$). The result of path analysis showed that SCF had an effect on OCT-4 expression ($p < 0.001$; $\beta = 0.985$) (Table 4) (Figure 6).

Table 3. Results on SCF expression.

Time (hour)	Experimental group	Mean \pm SD	p
24	Normoxia	0.084 \pm 0.019	0.000
	Hypoxia	0.990 \pm 0.013	
48	Normoxia	0.093 \pm 0.014	0.000
	Hypoxia	0.901 \pm 0.082	
72	Normoxia	0.075 \pm 0.024	0.000
	Hypoxia	0.596 \pm 0.087	

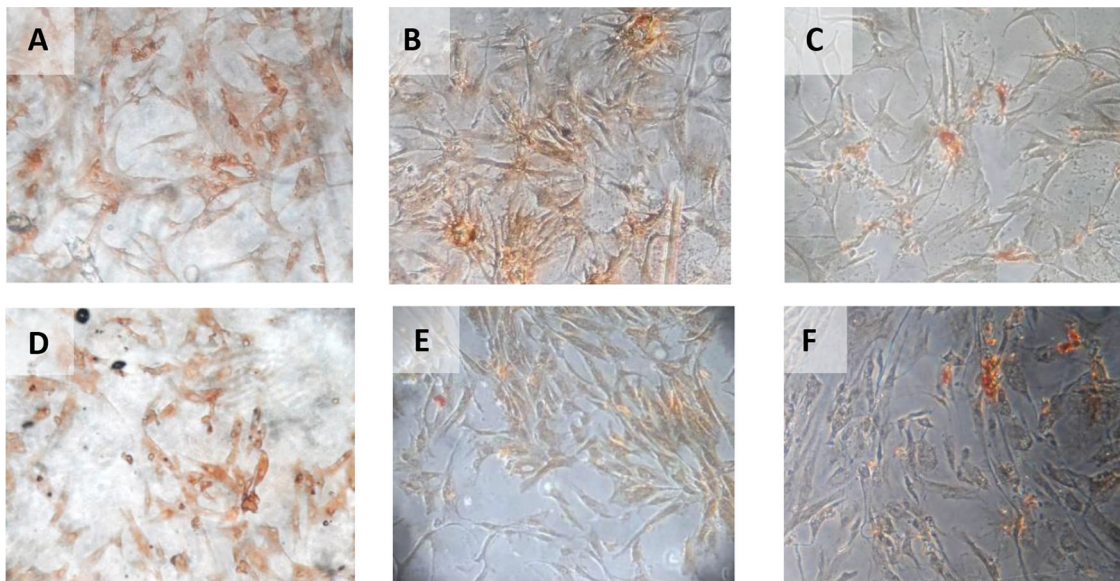

Figure 5. Immunohistochemical Characteristic of h-AMSCs based on SCF expression at: A) normoxic condition for 24 hours; B) normoxic condition for 48 hours; C) normoxic condition for 72 hours; D) hypoxic condition for 24 hours; E) hypoxic condition for 48 hours; F) hypoxic condition for 72 hours.

Table 4. Results on OCT4 expression.

Time (hour)	Experimental group	Mean \pm SD	p
24	Normoxia	0.148 \pm 0.018	0.000
	Hypoxia	0.793 \pm 0.034	
48	Normoxia	0.110 \pm 0.007	0.000
	Hypoxia	0.673 \pm 0.047	
72	Normoxia	0.099 \pm 0.025	0.000
	Hypoxia	0.457 \pm 0.151	

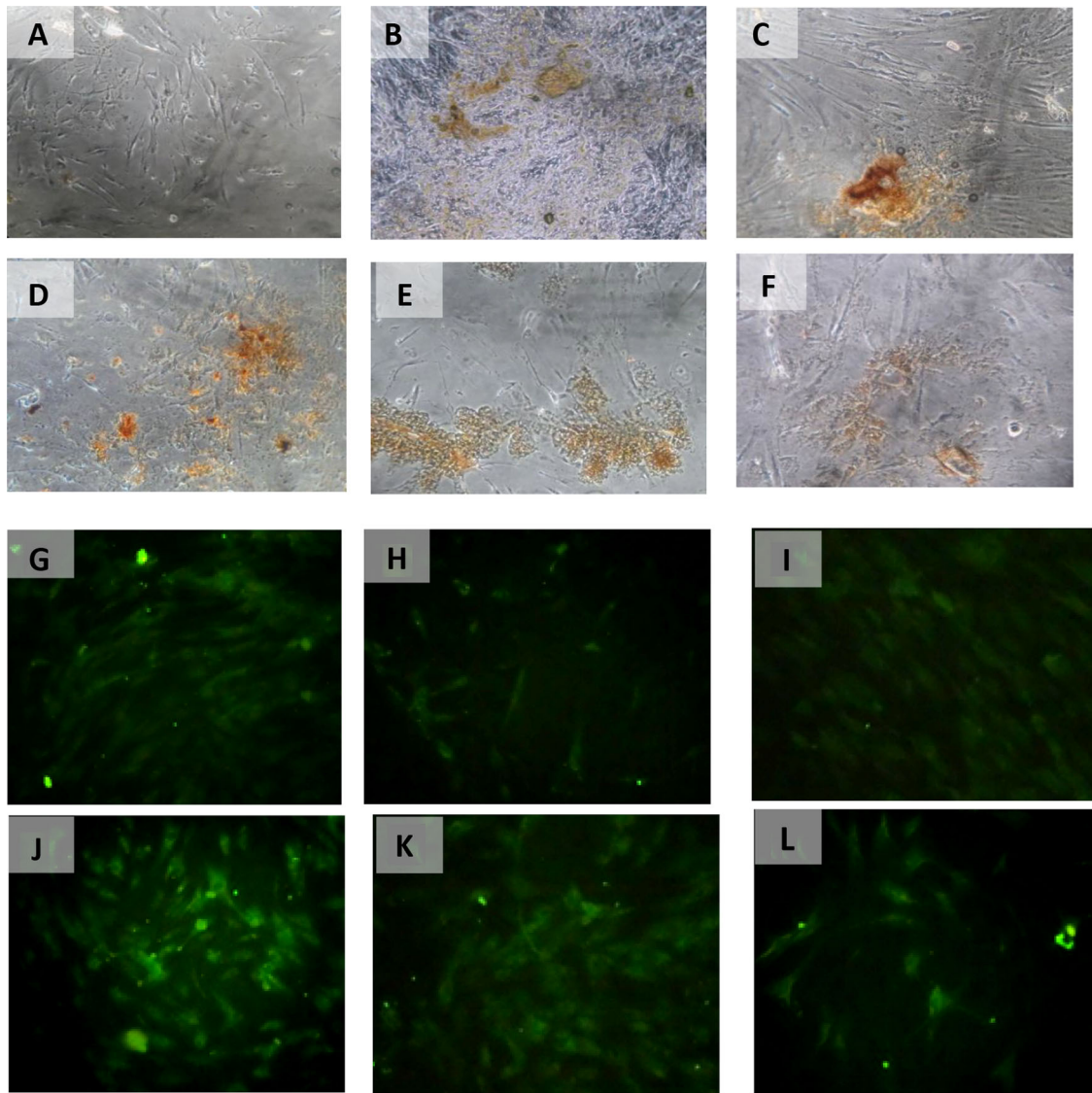

Figure 6. Immunohistochemical Characteristic of *h-AMSCs* based on OCT-4 expression at: A) normoxic condition for 24 hours; B) normoxic condition for 48 hours; C) normoxic condition for 72 hours; D) hypoxic condition for 24 hours; E) hypoxic condition for 48 hours; F) hypoxic condition for 72 hours. Immunofluorescence assay of *h-AMSCs* based on OCT-4 expression at: G) normoxic condition for 24 hours; H) normoxic condition for 48 hours; I) normoxic condition for 72 hours; J) hypoxic condition for 24 hours; K) hypoxic condition for 48 hours; L) hypoxic condition for 72 hours.

Table 5. Results on BCL2 expression.

Time (hour)	Experimental group	Mean ± SD	p
24	Normoxia	0.100 ± 0.010	0.000
	Hypoxia	0.714 ± 0.073	
48	Normoxia	0.093 ± 0.025	0.020
	Hypoxia	0.505 ± 0.185	
72	Normoxia	0.141 ± 0.012	0.026
	Hypoxia	0.479 ± 0.229	

The results of time difference test on BCL2 expression between 24 hours with 48 hours ($p = 0.223$), 24 hours with 72 hours ($p = 0.295$), and 48 hours with 72 hours ($p = 0.982$). Path analysis results show that OCT-4 effect on BCL2 expression ($p < 0.001$; $\beta = 0.878$) (Table 5) (Figure 7).

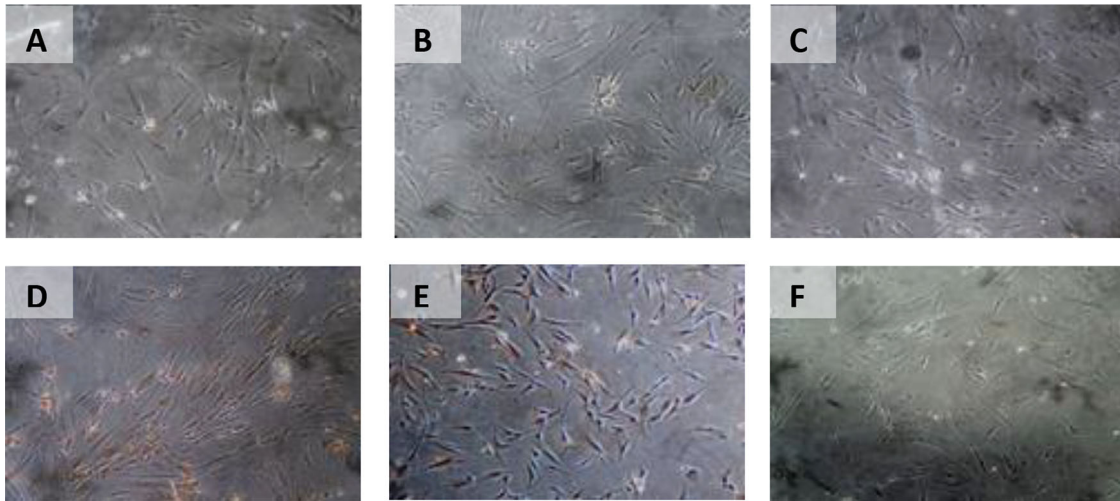

Figure 7. Immunohistochemical Characteristic of *h-AMSCs* based on BCL2 expression at: A) normoxic condition for 24 hours; B) normoxic condition for 48 hours; C) normoxic condition for 72 hours; D) hypoxic condition for 24 hours; E) hypoxic condition for 48 hours; F) hypoxic condition for 72 hours.

Table 6. Results on HSP27 expression.

Time (hour)	Experimental group	Mean ± SD	p
24	Normoxia	0.156 ± 0.024	0.000
	Hypoxia	0.967 ± 0.018	
48	Normoxia	0.157 ± 0.106	0.000
	Hypoxia	0.773 ± 0.132	
72	Normoxia	0.055 ± 0.036	0.000
	Hypoxia	0.389 ± 0.037	

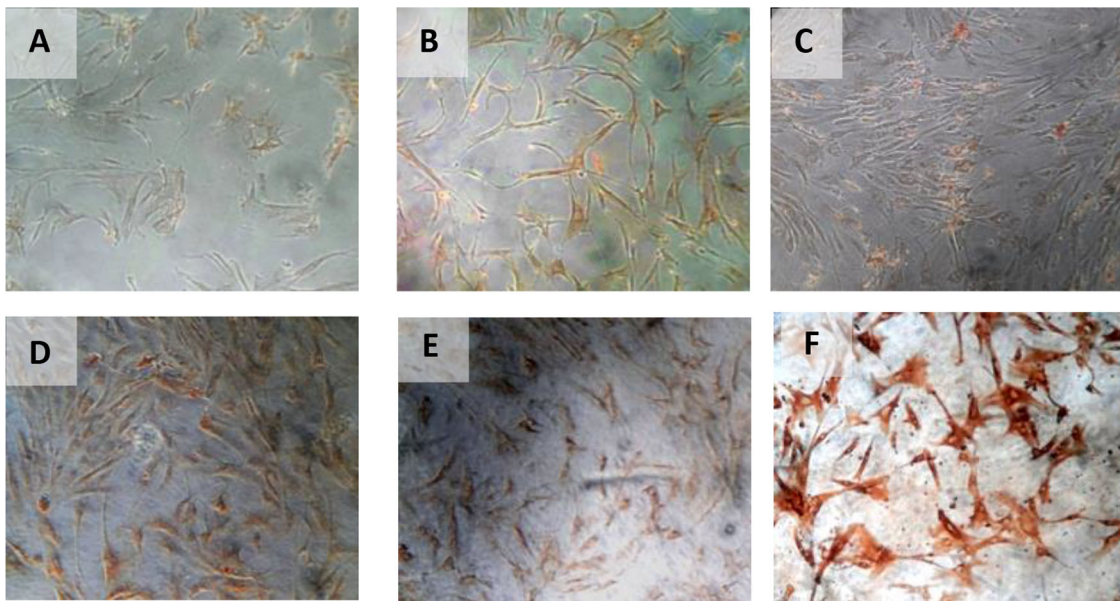

Figure 8. Immunohistochemical Characteristic of *h-AMSCs* based on HSP27 expression at: A) normoxic condition for 24 hours; B) normoxic condition for 48 hours; C) normoxic condition for 72 hours; D) hypoxic condition for 24 hours; E) hypoxic condition for 48 hours; F) hypoxic condition for 72 hours.

The results of the time difference test on HSP27 expression between 24 hours with 48 hours ($p = 0.040$), 24 hours with 72 hours ($p < 0.001$), and 48 hours with 72 hours ($p < 0.001$). The regression test results showed that time effects on HSP27 expression ($p < 0.001$; $\beta = -0.398$) and hypoxia precondition also affects HSP27 expression ($p < 0.001$; $\beta = 0.847$) (Table 6) (Figure 8).

Table 7. Results on number of apoptotic cell amount.

Time (hour)	Experimental group	Mean \pm SD	<i>p</i>
24	Normoxia	0.945 \pm 0.034	0.000
	Hypoxia	0.088 \pm 0.026	
48	Normoxia	0.777 \pm 0.043	0.000
	Hypoxia	0.148 \pm 0.027	
72	Normoxia	0.881 \pm 0.096	0.000
	Hypoxia	0.183 \pm 0.021	

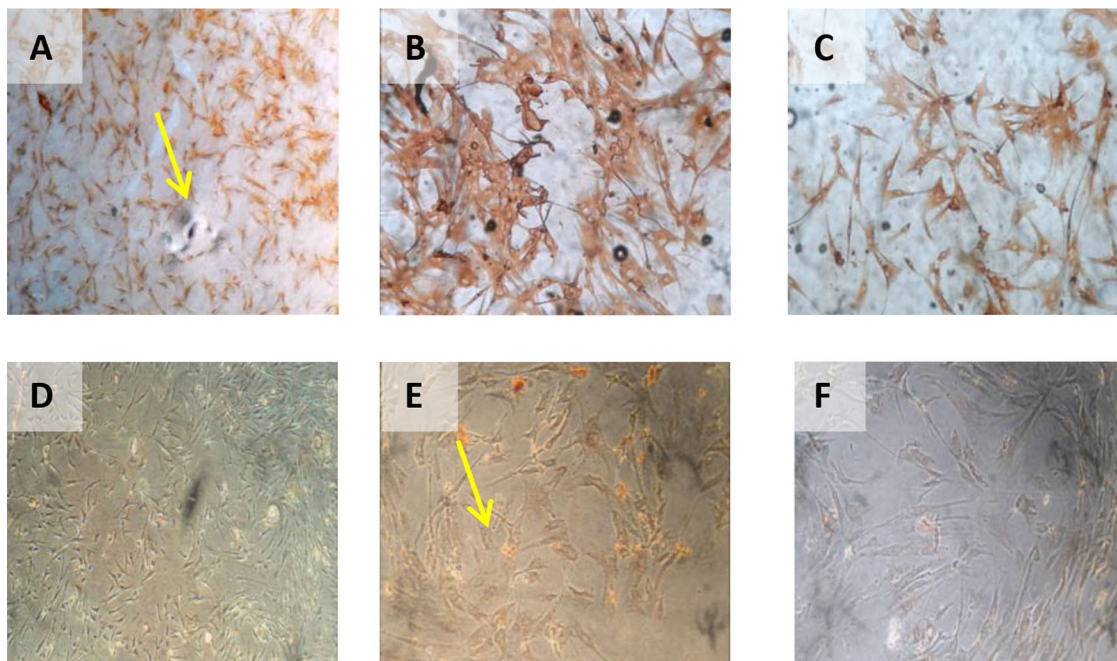

Figure 9. Immunohistochemical Characteristic of *h*-AMSCs based on number of apoptotic cell amount at: A) normoxic condition for 24 hours; B) normoxic condition for 48 hours; C) normoxic condition for 72 hours; D) hypoxic condition for 24 hours; E) hypoxic condition for 48 hours; F) hypoxic condition for 72 hours.

The results of time difference test on number of apoptotic cell amount between 24 hours with 48 hours ($p = 0.004$), 24 hours with 72 hours ($p = 0.562$), and 48 hours with 72 hours ($p < 0.001$). Pathway analysis showed that BCL2 expression inhibited apoptosis ($p = 0.030$; $\beta = -0.442$) and HSP27 expression also inhibited apoptosis ($p < 0.001$; $\beta = -0.487$) (Table 7) (Figure 9).

Discussion

Over the last few years, with the gradual increase in awareness of the critical role that hypoxia-induced signalling could play as a tool for generating angiogenesis on demand, two distinct approaches have emerged, as promising strategies to achieve this goal.⁵ On one hand, researchers have explored the possibility of pre-conditioning cells or grafts to hypoxia *in vitro*, in order to upregulate the required signalling that can then initiate angiogenesis *in vivo* upon transplantation.¹¹ The second approach relies on direct induction of hypoxia-mediated signalling *in vivo*, by pharmacological means or gene therapy.¹² A further distinction can be made on whether the therapy involves transplantation of hypoxia pre-conditioned or genetically modified cells, or if the effect is mediated directly through gene transfer or cell-free delivery of hypoxia-induced protein factors.¹³

The low survival of *h*-AMSCs after transplanting the heart muscle with myocardial infarction has limited the effectiveness of stem cell therapy.⁸ This is presumably because the transplanted stem cells are difficult to adapt to a new environment that is different from the environment during the *in vitro* culture process if it is carried out under normoxic

conditions (21% oxygen concentration), while the niche of h-AMSCs in adipose tissue is actually under hypoxic conditions (oxygen concentration between 2-8%).¹⁴ The mechanism underlying the decreased effectiveness of stem cells when transplanted is thought to be because many transplanted stem cells undergo apoptosis.¹⁵ Therefore, a strategy is needed to increase the resistance of transplanted stem cells, one of which is the hypoxic adaptation process during *in vitro* culture.¹⁶

The role of sub lethal hypoxia during the *in vitro* culture process is to provide hypoxic preconditions so that the support niche is compatible with the hypoxic environment *in vivo* in myocardial infarction.¹⁷ Hypoxic precondition will trigger Vascular Endothelial Growth Factor (VEGF) which then binds to VEGF Receptor-1 (VEGFR-1) in the cytosol.¹⁸ The presence of VEGF - VEGFR-1 bonds is thought to occur in a series of signalling which activates Stem Cell Factor (SCF) or Steel Factor (SLF) in the interstitial.¹⁹ Interstitial SCF expression will be recognized by the SCF receptor so that an SCF-receptor complex is formed in the cell nucleus and nuclear β 1-integrin expression will activate Octamer-4 (OCT-4) so that stem cells experience proliferation, self-renewal but still have the potential for differentiation.^{20,21} OCT-4 also plays a role in the activation of the PI3/Akt pathway which affects survival cells by increasing BCL2 in the cytosol, resulting in inhibition of BAX, which causes mitochondrial PT-Pore to remain closed.²² The closure of the PT-Pore from the mitochondria will inhibit the release of Cytochrome-C and Apoptotic protease activating factor-1 (APAF-1) so that the apoptotic cascade does not occur.²³

Furthermore, the hypoxic precondition will lead to the expression of Cluster of Differentiation 44+ (CD44+).²⁴ This CD44+ expression occurs due to stimulation of the nuclear β 1 integrin from the cell nucleus which is expressed due to the presence of the SCF-receptor complex bond.²⁵ CD44+ is a hyaluronan receptor which is part of the adhesion molecule, causing interactions between cells and between cells and the matrix, as well as lymphocyte activation, also plays a role in the homing process, and increases cell migration.²⁶ CD44+ is a polymorphic family that is immunologically related to proteoglycans and cell surface glycoproteins as markers of h-AMSCs. Apart from being a marker for h-AMSCs, CD44 + has a signalling function that plays a role in cell survival and motility.²⁶

On the other hand, hypoxic conditions are thought to have an effect on mitochondria in increasing the expression of Reactive Oxygen Species (ROS).²⁷ The increased ROS due to hypoxic conditions is thought to be the cause of the increase in free radicals formed through mitochondrial-mediated pathways.²⁸ This triggers protein kinase-C (PKC) and protein K-2 (PK2) which then triggers the p53 gene so that there is an increase in p53 protein expression which will activate proapoptotic members such as BAX.²⁹ Increased expression of p53 causes mitochondrial damage which causes pores to open in the membrane, so that Cytochrome-C and other molecules that act as APAF-1 will exit the mitochondria.³⁰ This condition will activate procaspase 9 to become caspase-9 and followed by activation of procaspase 3 to become active caspase-3 which affects DNase so that DNA fragmentation occurs, and ends with cell death through the apoptosis process.²⁹

However, the low sublethal oxygen concentration is thought to activate cells for protection in the form of repair.³¹ The repair process can be done through the activation of heat shock factor-1 (HSF-1) so that the formation of several Heat Shock Proteins (HSPs) occurs.³² HSPs are the product of several gene families contained in the cell nucleus which act as chaperone molecules that play a role in cell survival during the stress process.³³ Some of the HSPs that were thought to be involved were HSP70, HSP90 α and HSP27.³² However, in hypoxic conditions that cause the glycolysis process. This glycolysis process will further affect Krebs's cycles so that ATP synthesis decreases.³⁴ This decrease in ATP concentration is thought to cause a decrease in the function of HSP70 and HSP90 α . This is because HSP70 and HSP90 α are ATP-dependent chaperone molecules, thus the two HSPs (HSP70 and HSP90 α) do not have the ability to act as chaperones in protecting, protecting and repairing cells under stress.³⁵ The role of chaperone molecules in hypoxic conditions is carried out by HSP27, because HSP27 is ATP-independent chaperone. In addition, hypoxic precondition can maintain multipotential properties through OCT-4 expression compared to normoxic conditions.³⁶

Conclusion

From this study, it can be concluded that the hypoxic preconditioning affect the survival of h-AMSC with different apoptotic presentations due to the increased expression of BCL2 (anti apoptotic protein) and HSP 27 as chaperone proteins that play a role in inhibiting apoptosis. In this study, the hypoxic preconditioning may elevate the expression of studied variables, such as the number of apoptosis through BCL2 and HSP27 expression, trigger signal through VEGF expression, proliferation through SCF expression, and multipotency through OCT-4 expression. Hypoxic preconditioning significantly affects VEGF, VEGF affects SCF expression, SCF affects OCT-4 expression, OCT-4 affects BCL2 expression, but hypoxia also affects HSP27 expression. BCL2 and HSP27 have proven inhibiting apoptosis thus enhancing h-AMSCs survival (Figure 10). In conclusion, hypoxic preconditioning of h-AMSC culture has proven to increase the expression of VEGF, SCF, OCT-4, and BCL2 and HSP27. This study demonstrated and explained the

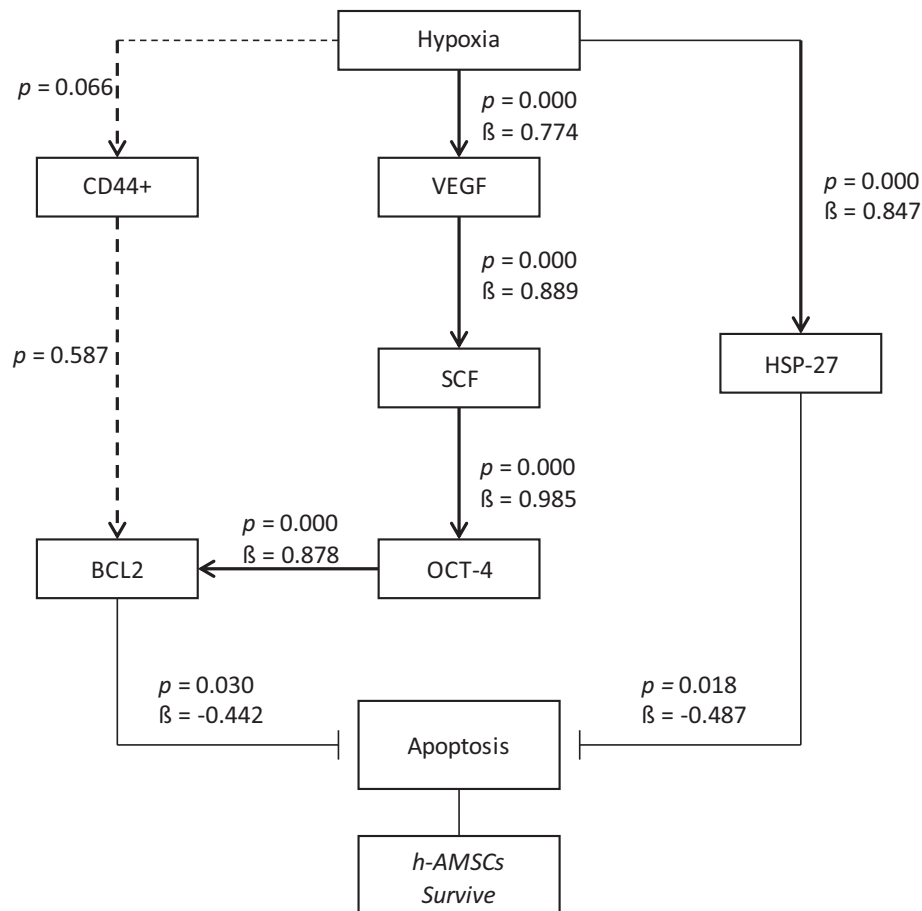

Figure 10. Path analysis with MANOVA and multiple linear regression analysis for hypoxic preconditioning in h-AMSCs survive.

existence of a new mechanism of increased h-AMSC survival in cultures with hypoxic preconditioning (O₂ 1%) via VEGF, SCF, OCT-4, BCL2, and HSP 27. But CD 44+ did not play a role in the mechanism of survival improvement of human AMSC survival.

Data availability

Underlying data

Figshare: Raw Data - Hypoxic Preconditioning Promotes Survivals of Human Adipocyte Mesenchymal Stem Cell via Expression of Prosurvival and Proangiogenic Biomarkers. <https://doi.org/10.6084/m9.figshare.15029016.v1>.³⁷

This project contains the following underlying data:

- Data file 1. Raw Data.xlsx

Data are available under the terms of the [Creative Commons Attribution 4.0 International license](https://creativecommons.org/licenses/by/4.0/) (CC-BY 4.0).

Acknowledgement

We would also like to show our gratitude to Dr. Andrianto and Dr. Meity Ardiana for sharing their pearls of wisdom with us during the writing process, and we thank for anonymous residents and staffs for their so-called insights. We are also immensely grateful to all professors and consultants from Department of Cardiology and Vascular Medicine – Faculty of Medicine, Universitas Airlangga for their comments on an earlier version of the manuscript, although any errors are our own and should not tarnish the reputations of these esteemed persons.

A previous version of this paper is available at bioRxiv 2021.01.18.427057; <https://www.biorxiv.org/content/10.1101/2021.01.18.427057v1>).

References

1. Stepniewski J, Tomczyk M, Andrysiak K, et al.: **Human Induced Pluripotent Stem Cell-Derived Cardiomyocytes, in Contrast to Adipose Tissue-Derived Stromal Cells, Efficiently Improve Heart Function in Murine Model of Myocardial Infarction.** *Biomedicines.* 2020; **8**(12): 1–21.
[PubMed Abstract](#) | [Publisher Full Text](#) | [Free Full Text](#)
2. Acquistapace A, Bru T, Lesault PF, et al.: **Human mesenchymal stem cells reprogram adult cardiomyocytes toward a progenitor-like state through partial cell fusion and mitochondria transfer.** *Stem Cells.* 2011; **29**(5): 812–824.
[PubMed Abstract](#) | [Publisher Full Text](#) | [Free Full Text](#)
3. Lee J, Lee S, Lee CY, et al.: **Adipose-derived stem cell-released osteoprotegerin protects cardiomyocytes from reactive oxygen species-induced cell death.** *Stem Cell Res Ther.* 2017; **8**(1): 4–9.
[PubMed Abstract](#) | [Publisher Full Text](#) | [Free Full Text](#)
4. Bagheri-Hosseinabadi Z, Mesbah-Namin SA, Salehinejad P, et al.: **Fibrin scaffold could promote survival of the human adipose-derived stem cells during differentiation into cardiomyocyte-like cells.** *Cell Tissue Res.* 2018; **372**(3): 571–589.
[PubMed Abstract](#) | [Publisher Full Text](#)
5. Lauvrud AT, Kelk P, Wiberg M, et al.: **Characterization of human adipose tissue-derived stem cells with enhanced angiogenic and adipogenic properties.** *J Tissue Eng Regen Med.* 2017; **11**(9): 2490–2502.
[PubMed Abstract](#) | [Publisher Full Text](#)
6. Green LJ, Zhou H, Padmanabhan V, et al.: **Adipose-derived stem cells promote survival, growth, and maturation of early-stage murine follicles.** *Stem Cell Res Ther.* 2019; **10**(1): 1–13.
[PubMed Abstract](#) | [Publisher Full Text](#) | [Free Full Text](#)
7. Yue Y, Zhang P, Liu D, et al.: **Hypoxia preconditioning enhances the viability of ADSCs to increase the survival rate of ischemic skin flaps in rats.** *Aesthetic Plast Surg.* 2013; **37**(1): 159–170.
[PubMed Abstract](#) | [Publisher Full Text](#)
8. Wang JW, Qiu YR, Fu Y, et al.: **Transplantation with hypoxia-preconditioned mesenchymal stem cells suppresses brain injury caused by cardiac arrest-induced global cerebral ischemia in rats.** *J Neurosci Res.* 2017; **95**(10): 2059–2070.
[PubMed Abstract](#) | [Publisher Full Text](#)
9. Wang XY, Liu CL, Li SD, et al.: **Hypoxia precondition promotes adipose-derived mesenchymal stem cells based repair of diabetic erectile dysfunction via augmenting angiogenesis and neuroprotection.** *PLoS One.* 2015; **10**(3): 1–18.
[PubMed Abstract](#) | [Publisher Full Text](#) | [Free Full Text](#)
10. Noordzij M, Dekker FW, Zoccali C, et al.: **Sample size calculations.** *Nephron - Clin Pract.* 2011; **118**(4): 319–323.
[PubMed Abstract](#) | [Publisher Full Text](#)
11. Nouri F, Nematollahi-Mahani SN, Sharifi AM: **Preconditioning of mesenchymal stem cells with non-toxic concentration of hydrogen peroxide against oxidative stress induced cell death: The role of hypoxia-inducible factor-1.** *Adv Pharm Bull.* 2019; **9**(1): 76–83.
[PubMed Abstract](#) | [Publisher Full Text](#) | [Free Full Text](#)
12. Hu C, Li L: **Preconditioning influences mesenchymal stem cell properties in vitro and in vivo.** *J Cell Mol Med.* 2018; **22**(3): 1428–1442.
[PubMed Abstract](#) | [Publisher Full Text](#) | [Free Full Text](#)
13. Hou J, Wang L, Long H, et al.: **Hypoxia preconditioning promotes cardiac stem cell survival and cardiogenic differentiation in vitro involving activation of the HIF-1 α /apelin/APJ axis.** *Stem Cell Res Ther.* 2017; **8**(1): 1–12.
[PubMed Abstract](#) | [Publisher Full Text](#) | [Free Full Text](#)
14. Mas-Bargues C, Sanz-Ros J, Román-Domínguez A, et al.: **Relevance of oxygen concentration in stem cell culture for regenerative medicine.** *Int J Mol Sci.* 2019; **20**(5).
[PubMed Abstract](#) | [Publisher Full Text](#) | [Free Full Text](#)
15. Liu H, Xue W, Ge G, et al.: **Hypoxic preconditioning advances CXCR4 and CXCR7 expression by activating HIF-1 α in MSCs.** *Biochem Biophys Res Commun.* 2010; **401**(4): 509–515.
[PubMed Abstract](#) | [Publisher Full Text](#)
16. Theus MH, Wei L, Cui L, et al.: **In vitro hypoxic preconditioning of embryonic stem cells as a strategy of promoting cell survival and functional benefits after transplantation into the ischemic rat brain.** *Exp Neurol.* 2008; **210**(2): 656–670.
[PubMed Abstract](#) | [Publisher Full Text](#)
17. Wei ZZ, Zhu YB, Zhang JY, et al.: **Priming of the cells: Hypoxic preconditioning for stem cell therapy.** *Chin Med J (Engl).* 2017; **130**(19): 2361–2374.
[PubMed Abstract](#) | [Publisher Full Text](#) | [Free Full Text](#)
18. Ramakrishnan S, Anand V, Roy S: **Vascular endothelial growth factor signaling in hypoxia and inflammation.** *J Neuroimmune Pharmacol.* 2014; **9**(2): 142–160.
[PubMed Abstract](#) | [Publisher Full Text](#) | [Free Full Text](#)
19. Nakayama: **Erratum: Vascular endothelial growth factor synergistically enhances bone morphogenetic protein-4 dependent lymphohematopoietic cell generation from embryonic stem cells in vitro (Blood (April 1, 2000) 95 (2275-2283)).** *Blood.* 2000; **96**(4): 1273.
[Publisher Full Text](#)
20. Gilmore AP, Metcalfe AD, Romer LH, et al.: **Integrin-mediated survival signals regulate the apoptotic function of Bax through its conformation and subcellular localization.** *J Cell Biol.* 2000; **149**(2): 431–445.
[PubMed Abstract](#) | [Publisher Full Text](#) | [Free Full Text](#)
21. Bachelder RE, Ribick MJ, Marchetti A, et al.: **p53 Inhibits α 6 β 4 integrin survival signaling by promoting the caspase 3-dependent cleavage of AKT/PKB.** *J Cell Biol.* 1999; **147**(5): 1063–1072.
[PubMed Abstract](#) | [Publisher Full Text](#) | [Free Full Text](#)
22. Bernardi P, Di Lisa F: **The mitochondrial permeability transition pore: Molecular nature and role as a target in cardioprotection.** *J Mol Cell Cardiol.* 2015; **78**: 100–106.
[PubMed Abstract](#) | [Publisher Full Text](#) | [Free Full Text](#)
23. Korsmeyer SJ, Wei MC, Saito M, et al.: **Pro-apoptotic cascade activates BID, which oligomerizes BAK or BAX into pores that result in the release of cytochrome c.** *Cell Death Differ.* 2000; **7**(12): 1166–1173.
[PubMed Abstract](#) | [Publisher Full Text](#)
24. Liang G, Li S, Du W, et al.: **Hypoxia regulates CD44 expression via hypoxia-inducible factor-1 α in human gastric cancer cells.** *Oncol Lett.* 2017; **13**(2): 967–972.
[PubMed Abstract](#) | [Publisher Full Text](#) | [Free Full Text](#)
25. Sun Z, Guo SS, Fässler R: **Integrin-mediated mechanotransduction.** 2016; **215**(4).
26. Misra S, Hascall VC, Markwald RR, et al.: **Interactions between hyaluronan and its receptors (CD44, RHAMM) regulate the activities of inflammation and cancer.** *Front Immunol.* 2015; **6**(MAY).
[PubMed Abstract](#) | [Publisher Full Text](#) | [Free Full Text](#)
27. Sena LA, Chandel NS: **Physiological roles of mitochondrial reactive oxygen species.** *Mol Cell.* 2012; **48**(2): 158–167.
[PubMed Abstract](#) | [Publisher Full Text](#) | [Free Full Text](#)
28. Schieber M, Chandel NS: **ROS function in redox signaling.** *Curr Biol.* 2014; **24**(10): 453–462.
[PubMed Abstract](#) | [Publisher Full Text](#) | [Free Full Text](#)
29. Volpe CMO, Villar-Delfino PH, Dos Anjos PMF, et al.: **Cellular death, reactive oxygen species (ROS) and diabetic complications review-Article.** *Cell Death Dis.* 2018; **9**(2).
[PubMed Abstract](#) | [Publisher Full Text](#) | [Free Full Text](#)
30. Garrido C, Galluzzi L, Brunet M, et al.: **Mechanisms of cytochrome c release from mitochondria.** *Cell Death Differ.* 2006; **13**(9): 1423–1433.
[PubMed Abstract](#) | [Publisher Full Text](#)
31. Darby IA, Hewitson TD: **Hypoxia in tissue repair and fibrosis.** *Cell Tissue Res.* 2016; **365**(3): 553–562.
[PubMed Abstract](#) | [Publisher Full Text](#)
32. Jacob P, Hirt H, Bendahmane A: **The heat-shock protein/chaperone network and multiple stress resistance.** *Plant Biotechnol J.* 2017; **15**(4): 405–414.
[PubMed Abstract](#) | [Publisher Full Text](#) | [Free Full Text](#)
33. Shende P, Bhandarkar S, Prabhakar B: **Heat Shock Proteins and their Protective Roles in Stem Cell Biology.** *Stem Cell Rev Reports.* 2019; **15**(5): 637–651.
[PubMed Abstract](#) | [Publisher Full Text](#)
34. Ryall JG, Cliff T, Dalton S, et al.: **Metabolic Reprogramming of Stem Cell Epigenetics.** *Cell Stem Cell.* 2015; **17**(6): 651–662.
[PubMed Abstract](#) | [Publisher Full Text](#) | [Free Full Text](#)
35. Wang Q, Li X, Wang Q, et al.: **Heat shock pretreatment improves mesenchymal stem cell viability by heat shock proteins and autophagy to prevent cisplatin-induced granulosa cell apoptosis.** *Stem Cell Res Ther.* 2019; **10**(1): 1–12.
[PubMed Abstract](#) | [Publisher Full Text](#) | [Free Full Text](#)
36. Hernandez I, Baio JM, Tsay E, et al.: **Short-term hypoxia improves early cardiac progenitor cell function in vitro.** *Am J Stem Cells.* 2018; **7**(1): 1–17.
[Reference Source](#)
37. Suryawan IGR, Pikir BS, Rantam FA, et al.: **Raw Data - Hypoxic Preconditioning Promotes Survivals of Human Adipocyte Mesenchymal Stem Cell via Expression of Prosurvival and Proangiogenic Biomarkers.** *Figshare.* 2021.

The benefits of publishing with F1000Research:

- Your article is published within days, with no editorial bias
- You can publish traditional articles, null/negative results, case reports, data notes and more
- The peer review process is transparent and collaborative
- Your article is indexed in PubMed after passing peer review
- Dedicated customer support at every stage

For pre-submission enquiries, contact research@f1000.com

F1000Research