

**LAPORAN AKHIR TAHUN  
PENELITIAN DASAR UNGGULAN PERGURUAN TINGGI  
PDUPT**



**Program Induce Pluripotent Stem Cells (IPs) melalui Metode Fisis  
Low Oksigen Tension yang Aplikatif dan Aman  
Tanpa Penyisipan Gen Vektor Virus**

**Tahun ke 2 dari rencana 4 tahun**

<b>Dr. Erma Safitri, M.Si., Drh.</b>	<b>0023076903</b>
<b>Dr. Thomas V. Widiyatno, M.Si., Drh.</b>	<b>0017105809</b>
<b>Dr. Willy Sandhika, dr., M.Si, Sp.PA(K)</b>	<b>0014036403</b>

**DIBIYAI OLEH:  
DIREKTORAT RISET DAN PENGABDIAN MASYARAKAT  
DIREKTORAT JENDERAL PENGUATAN RISET DAN PENGEMBANGAN  
KEMENTERIAN RISET, TEKNOLOGI, DAN PENDIDIKAN TINGGI  
SESUAI DENGAN PERJANJIAN PENDANAAN PENELITIAN DAN PENGABDIAN  
KEPADA MASYARAKAT  
NOMOR: 122/SP2H/PTNBH/DRPM/2018**

**UNIVERSITAS AIRLANGGA  
NOVEMBER 2018**



**LAPORAN AKHIR TAHUN  
PENELITIAN DASAR UNGGULAN PERGURUAN TINGGI  
PDUPT**



KKC  
KK  
LP 54/19  
Saf  
P

**Program Induce Pluripotent Stem Cells (IPs) melalui Metode Fisis  
Low Oksigen Tension yang Aplikatif dan Aman  
Tanpa Penyisipan Gen Vektor Virus**

Tahun ke 2 dari rencana 4 tahun

<b>Dr. Erma Safitri, M.Si., Drh.</b>	<b>0023076903</b>
<b>Dr. Thomas V. Widiyatno, M.Si., Drh.</b>	<b>0017105809</b>
<b>Dr. Willy Sandhika, dr., M.Si, Sp.PA(K)</b>	<b>0014036403</b>

**DIBIYAI OLEH:  
DIREKTORAT RISET DAN PENGABDIAN MASYARAKAT  
DIREKTORAT JENDERAL PENGUATAN RISET DAN PENGEMBANGAN  
KEMENTERIAN RISET, TEKNOLOGI, DAN PENDIDIKAN TINGGI  
SESUAI DENGAN PERJANJIAN PENDANAAN PENELITIAN DAN PENGABDIAN  
KEPADA MASYARAKAT  
NOMOR: 122/SP2H/PTNBH/DRPM/2018**

**UNIVERSITAS AIRLANGGA  
NOVEMBER 2018**



FILE  
PUSAT PERPUSTAKAAN  
UNIVERSITAS AIRLANGGA  
JAYABASU

**HALAMAN PENGESAHAN**

Judul : PROGRAM INDUCE PLURIPOTENT STEM CELLS (iPS) MELALUI METODEDEFISIS LOW OKSIGEN TENSION YANG APLIKATIF DAN AMAN TANPA PENYISIPAN GEN VEKTOR VIRUS

**Peneliti/Pelaksana**

Nama Lengkap : Dr. drh. ERMA SAFITRI, M.Si  
Perguruan Tinggi : Universitas Airlangga  
NIDN : 0023076903  
Jabatan Fungsional : Lektor  
Program Studi : Kedokteran Hewan  
Nomor HP : 087853431053  
Alamat surel (e-mail) : rma\_fispro@yahoo.com

**Anggota (1)**

Nama Lengkap : Dr. drh. THOMAS VALENTINUS WIDIYATNO M.Si  
NIDN : 0017105809  
Perguruan Tinggi : Universitas Airlangga

**Anggota (2)**

Nama Lengkap : Dr. dr. WILLY SANDHIKA M.Si, Sp.P.K, Sp.PA.(K).  
NIDN : 0014036403  
Perguruan Tinggi : Universitas Airlangga

**Institusi Mitra (jika ada)**

Nama Institusi Mitra : -  
Alamat : -  
Penanggung Jawab : -  
Tahun Pelaksanaan : Tahun ke 2 dari rencana 4 tahun  
Biaya Tahun Berjalan : Rp 220,000,000  
Biaya Keseluruhan : Rp 956,118,500

Mengetahui,  
Dekan FKH Unair



(Prof. Dr. Pudi Sianto, M.Kes.,Drh.)  
NIP/NIK 195601051986011001

Kota Surabaya, 10 - 11 - 2018  
Ketua,



(Dr. drh. ERMA SAFITRI, M.Si)  
NIP/NIK 196907231999032001

Menyetujui,  
Ketua Lembaga Penelitian dan Inovasi Unair



(Prof. Drs. Hery Purnobasuki, M.Si., Ph.D)  
NIP/NIK 196705071991021001



DAFTAR ISI

1	1
2	2
3	3
4	4
5	5
6	6
7	7
8	8
9	9
10	10
11	11
12	12
13	13
14	14
15	15
16	16
17	17
18	18
19	19
20	20
21	21
22	22
23	23
24	24
25	25
26	26
27	27
28	28
29	29
30	30
31	31
32	32
33	33
34	34
35	35
36	36
37	37
38	38
39	39
40	40
41	41
42	42
43	43
44	44
45	45
46	46
47	47
48	48
49	49
50	50
51	51
52	52
53	53
54	54
55	55
56	56
57	57
58	58
59	59
60	60
61	61
62	62
63	63
64	64
65	65
66	66
67	67
68	68
69	69
70	70
71	71
72	72
73	73
74	74
75	75
76	76
77	77
78	78
79	79
80	80
81	81
82	82
83	83
84	84
85	85
86	86
87	87
88	88
89	89
90	90
91	91
92	92
93	93
94	94
95	95
96	96
97	97
98	98
99	99
100	100

Disetujui oleh:

*[Signature]*

Disetujui oleh:

Disetujui oleh:

*[Signature]*

Disetujui oleh:

Disetujui oleh:

*[Signature]*

Disetujui oleh:

Disetujui oleh:  
*[Signature]*

## PRAKATA

Puji syukur dipanjatkan kehadirat Allah S.W.T. atas Rahmat-Nya sehingga kami dapat menyelesaikan penelitian dengan judul **“Program Induce Pluripotent Stem Cells (Ips) Melalui Metode Fisis Low Oksigen Tension Yang Aplikatif Dan Aman Tanpa Penyisipan Gen Vektor Virus”**. Besar harapan kami agar penelitian ini bermanfaat bagi masyarakat di Indonesia.

Pada kesempatan ini kami menyampaikan terima kasih kepada Bapak Rektor Universitas Airlangga, Ketua Lembaga Penelitian dan Inovasi Universitas Airlangga, Ketua Institute Tropical Disease dan Ketua Lab. Stem Cells Institute Tropical Disease, dan Dekan Fakultas Kedokteran Hewan atas kesempatan serta fasilitas yang telah diberikan untuk melaksanakan program Penelitian Dasar Unggulan Perguruan Tinggi ini melalui pembiayaan oleh Direktorat Riset dan Pengabdian Masyarakat Direktorat Jenderal Penguatan Riset dan Pengembangan Kementerian Riset, Teknologi, dan Pendidikan Tinggi, sesuai dengan perjanjian pendanaan penelitian dan pengabdian kepada masyarakat nomor: 122/sp2h/ptnbh/drpm/2018

Semoga Allah S.W.T melimpahkan karunia dan Rahmat-Nya kepada semua pihak yang telah membantu terlaksananya penelitian ini.

Surabaya, November 2018

Penulis

## DAFTAR ISI

HALAMAN SAMPUL.....	0
HALAMAN PENGESAHAN .....	1
RINGKASAN .....	2
PRAKATA .....	3
DAFTAR ISI .....	4
DAFTAR TABEL .....	5
DAFTAR GAMBAR .....	6
DAFTAR LAMPIRAN .....	7
BAB 1 PENDAHULUAN .....	8
BAB 2 TINJAUAN PUSTAKA .....	9
BAB 3 TUJUAN DAN MANFAAT PENELITIAN .....	12
BAB 4 METODE PENELITIAN .....	13
BAB 5 HASIL DAN LUARAN YANG DICAPAI .....	21
BAB 6 RENCANA DAN TAHAP BERIKUTNYA .....	35
BAB 7 KESIMPULAN DAN SARAN .....	35
DAFTAR PUSTAKA .....	35
LAMPIRAN (bukti luaran yang didapatkan) .....	38
- Publikasi Seminar Internasional (Foto).....	28
- Bukti Accepted Vet World .....	29
- Bukti Accepted Biochem .....	30
- Sertifikat proofreading MDPI.....	31
- Sertifikat proofreading .....	32





**DAFTAR TABEL**

**Tabel**

**Halaman**

## DAFTAR GAMBAR

Gambar		Halaman
1	Isolasi r-AMSCs metode Liposuction .....	21
2	Isolasi r-AMSCs dengan sistem sentrifugasi <i>ficoll gradient density</i> .....	22
3	Pemeriksaan mikroskopis dari kultur Normoksia pada hari ke-1 samapai ke-3 .....	22
4	Karakterisasi secara Immunfluorescence : CD44+, CD90+, CD34-, CD45- .....	23
5	Analisis gen pengkode CD44 dengan PCR setelah perlakuan kondisi low O <sub>2</sub> tension dibandingkan dengan Normoksia yang divisualisas secara eletroforesis pada gel agarose 2% pewarnaan ethidium bromide . Hasil menunjukkan untaian cDNA sebesar 551 bp., M = Marker.....	24
6	Gambar 6. Analisis gen pengkode OCT4 dengan PCR setelah perlakuan prekondisi hipoksia (O <sub>2</sub> 1% dan 3%) yang dibandingkan dengan normoksia (O <sub>2</sub> 21%) yang divisualisasikan secara eletroforesis pada gel agarose 2% pewarnaan <i>ethidium bromide</i> . Hasil menunjukkan untaian cDNA sebesar 114 bp., M =Marker .....	24
7	Gambar.7. Analisis gen pengkode SOX2 dengan PCR setelah perlakuan prekondisi hipoksia yang divisualisas secara eletroforesis pada gel agarose 2% pewarnaan ethidium bromide. Hasil menunjukkan untaian cDNA sebesar 319 bp., M =Marker .....	25
8	Data raw <i>sequencing</i> susunan basa nukleotida gen pengkode CD44 .....	26
9	Data raw <i>sequencing</i> susunan basa nukleotida gen pengkode OCT4.....	27
10	Data raw <i>sequencing</i> susunan basa nukleotida gen pengkode SOX2 .....	27
11	Analisis penyejajaran didapatkan 4 data kecocokan hasil sekuens gen pengkode CD44 sampel dengan whole genom yang ada di gene bank (≥ 60%) .....	28
12	Hasil analisis sekuensing CD 44 dengan menggunakan <i>multiple alignment</i> setelah perlakuan prekondisi hipoksia .....	29
13	Whole genom CD44 .....	30
14	Analisis sekuensing OCT4 menggunakan <i>multiple alignment</i> .....	31
15	Analisis penyejajaran didapatkan 2 data kecocokan hasil sekuens gen pengkode OCT4 sampel dengan perlakuan hypoksia 1% dan 3% dengan whole genom di Gene Bank (≥ 60%).....	31
16	Whole genom OCT4 .....	32
17	Analisis <i>sequencing</i> SOX2 menggunakan <i>multiple alignment</i> .....	33
18	Analisis penyejajaran didapatkan 2 data kecocokan hasil sekuens gen pengkode SOX2 sampel dengan perlakuan hypoksia 1% dan 3% dengan whole genom di Gene Bank (≥ 60%).....	34
19	Whole genom SOX2 .....	34

**DAFTAR LAMPIRAN**

<b>Lampiran</b>		<b>Halaman</b>
1	Publikasi Seminar Internasional (Sertifikat).....	38
2	Bukti Accepted Vet World & Proofread .....	39
3	Bukti Accepted Biochem Archive and Celluar.....	41
4	Bukti Accepted Philippine Journal of Veterinari Science.....	43
5	Sertifikat proofreading MDPI.....	44
6	Sertifikat proofreading.....	45

## BAB 1. PENDAHULUAN

### Latar Belakang

Pengembangan Stem Cells merupakan salah satu dari 17 tema yang ditetapkan oleh Universitas Airlangga sebagai Rencana Strategis (Renstra) Unair dan tertuang pada Rencana Induk Penelitian (RIP) Universitas Airlangga tahun 2016-2020. Seperti diketahui, stem cells selain dapat melakukan replikasi dan menghasilkan sel-sel berkarakteristik sama dengan sel induknya (*self renewal*), juga mempunyai potensi untuk dapat berdiferensiasi menjadi sel tubuh apapun yang berasal dari ketiga lapisan embrional, seperti ektoderm, mesoderm, dan endoderm. Potensi menjadi ketiga lapisan embrional ini dikenal dengan istilah *pluripotency*. Namun demikian sifat *pluripotency* ini menurut Rizzino, (2009) hanya dimiliki oleh *embryonal stem cells* (ESCs) dan tidak pada *adult stem cells*. Menurut Halim dkk. (2010), menyebutkan bahwa dibandingkan *adult stem cells* yang bersifat multipotent maupun sel progenitor yang hanya mempunyai sifat *unipotent*, stem cells, khususnya ESCs memiliki potensi diferensiasi yang jauh lebih besar. ESCs yang berasal dari *inner cell mass* (ICM) dalam blastosis bersifat *pluripotent*, sehingga mampu berdiferensiasi menjadi berbagai jenis sel penyusun tubuh dari ketiga lapisan embrional. Namun sayangnya penggunaan ESCs dianggap melanggar kode etik, sehingga pemanfaatannya untuk terapi tidak diperkenankan.

Oleh karena itulah, dilakukan berbagai upaya agar sifat Pluripotency dapat diinduksi pada kultur *in vitro* *adult stem cells* melalui program *induce pluripotent stem cells* (iPS). Hal tersebut menjadi salah satu fokus utama pada penelitian *adult stem cells*, seperti halnya yang menjadi tujuan utama pada penelitian ini. Secara *in vivo*, dibutuhkan keseimbangan antara diferensiasi, apoptosis dan *self renewal* dari stem cells yang diregulasi oleh niche dari *microenvironment* dimana stem cells berada. Menurut Barria *et al.* (2004), pada kultur *in vitro* *feeder-free*, nasib stem cells selain dipengaruhi oleh *growth factor*, *interleukins* atau serum, dalam mempengaruhi keseimbangan antara *self renewal*, diferensiasi dan apoptosis, juga dipengaruhi kondisi yang diberikan pada saat proses kultur.

Selama ini program iPS telah terbukti berhasil dan menghantarkan penemunya professor Yamanaka, seorang ilmuwan dari Jepang mendapatkan NOBEL pada tahun 2013 (Jawa Pos, 2013). Hanya saja program iPS tersebut dilakukan melalui pemanfaatan transfeksi virus dengan 4 faktor transkripsi (OCT3/4, SOX2, C-MYC dan KLF4) yang dikenal sebagai “kuartet Yamanaka”. Transfeksi virus oleh Yamanaka adalah dengan menggunakan virus retroviral (Halim dkk. 2010).



Namun demikian, teknologi ini masih memiliki banyak kelemahan, seperti : 1. penggunaan virus sebagai vektor transfeksi berpotensi mengakibatkan terjadinya mutasi pada sel somatis (stem cells dewasa) yang diinfeksi pada kemudian hari; 2. keberhasilan transfeksi kuartet Yamanaka pada sel fibroblast hanya mencapai 0,01%, sehingga perlu dilakukan upaya transfeksi secara berulang kali, hal ini tentu saja tidak efektif dan efisien baik dari segi ekonomi maupun waktu; 3. Efek samping yang dapat ditimbulkan dikarenakan pemanfaatan jumlah faktor transkripsi yang terlalu banyak, belum lagi kerja faktor transkripsi ketika sudah ditransplantasikan secara *in vivo* ke dalam tubuh manusia tidak memungkinkan lagi untuk dapat melakukan kontrol atau kendali. Hal ini dimungkinkan karena sampai saat ini tidak ada satupun teknik yang dapat sepenuhnya mengontrol ekspresi gen manusia secara *in vivo*; 4. Kekhawatiran munculnya reaksi onkogenik akibat pemanfaatan penyisipan gen C-MYC yang merupakan gen yang bersifat onkogenik sehingga memunculkan resiko terjadinya suatu keganasan akibat program iPS dikemudian hari (Halim, dkk. 2010).

Oleh karena itulah diperlukan suatu solusi dan alternatif dalam upaya program *induce pluripotent stem cells* (iPS) tanpa melalui penyisipan gen faktor transkripsi pada berbagai vektor. Pada penelitian ini program *induce pluripotent stem cells* (iPS) dilakukan melalui pemanfaatan teknologi fisis, yaitu melalui pemberian *low oksigen* tension pada saat kultur *in vitro*. Penelitian sebelumnya yang telah dilakukan adalah pemberian *low oksigen* tension pada MSCs dari bone marrow pada pasase zero dan juga setelah pasase ke-3 (Safitri, 2014; Safitri *et al.*, 2014). Pada penelitian ini pemberian *low oksigen* tension akan diberikan setelah pasase ke-9, atau setelah terjadi perubahan pada stem cells baik secara molekuler maupun secara genomik yang dikenal sebagai *late passage*. Pada penelitian ini sumber stem cells berasal dari *rabbit - Adiposit Mesenchymal Stem Cells* (r-AMSCs), yang merupakan adult stem cells yang berasal dari sel somatik.

## BAB 2. TINJAUAN PUSTAKA

Sifat *pluripotency* pada kultur *in vitro* stem cells menjadi salah satu fokus utama pada penelitian-penelitian *adult* stem cells. Secara *in vivo*, dibutuhkan keseimbangan antara diferensiasi, apoptosis dan self renewal dari stem cells yang diregulasi oleh *niche* dari microenvironment dimana stem cells berada. Menurut Barria *et al.* (2004), pada kultur *in vitro feeder-free*, nasib stem cells selain dipengaruhi oleh *growth factor*, interleukins atau serum, dalam mempengaruhi keseimbangan antara *self renewal*, diferensiasi dan apoptosis, juga dipengaruhi kondisi yang diberikan pada saat proses kultur.





Salah satu keseimbangan yang dibutuhkan dalam mempertahankan sifat *pluripotency* adalah proses *self-renewal*. *Self-renewal* adalah proses dari stem cells untuk membuat lebih banyak stem cells itu sendiri (menggandakan diri sendiri), sehingga kehidupan stem cells *pool* menjadi abadi. *Self-renewal* adalah merupakan *maintenance* dari kondisi *undifferentiated* (He *et al.*, 2009a). Dibutuhkan kontrol terhadap siklus sel sehingga sifat *pluripotency* melalui proses *self-renewal* dapat diupayakan.

Melalui keseimbangan proses *self-renewal* menurut Kolf *et al.* (2007), memberi petunjuk biological pathway dan mekanisme pertahanan pada tahap *undifferent* stem. Susunan secara genomic telah digunakan untuk identifikasi molekuler dari *self-renewal* yang mempertahankan stem cells *state*, termasuk Mesenchymal Stem Cells (MSCs) (Song *et al.*, 2006) dan *Bone Marrow-Mesenchymal Stem Cells* (BMSCs) (Safitri, 2014). Pada penelitian ini identifikasi molekuler secara genomic dalam mempertahankan sifat *pluripotency* dilakukan pada *rabbit-Adiposit Mesenchymal Stem Cells* (r-AMSCs) melalui kultur pada *low* oksigen tension. Kultur *low* oksigen tension merupakan pemberian kondisi niche dan extra cellular factor yang dibutuhkan agar stem cells tetap dapat mempertahankan keseimbangan proses *self-renewal*, sehingga pada akhirnya sifat *pluripotency* dapat dipertahankan.

Pendekatan kandidat gen secara genomic tersebut seperti extra cellular factor, menurut Kolf *et al.* (2007) dan nichemenurut Arai and Suda (2008), dapat dijelaskan bahwa kedua factor tersebut dapat mempengaruhi *self-renewal* yang berujung pada kondisi *pluripotent*. Kondisi *pluripotent* tersebut didasarkan pada petanda marker khusus dari MSCs, seperti OCT-4, SOX-2 (Szablowska-Gadomska, *et al.*, 2011; Yamanaka, 2007), Rex-1 (Kolf *et al.*, 2007) dan KLF-4 (Yamanaka, 2007).

Bioteknologi di bidang kedokteran berbasis stem cell (sel punca) merupakan suatu fenomena yang sangat luar biasa di akhir abad ke-20. Stem cell mempunyai potensi dan harapan yang sangat menjanjikan bagi kesembuhan yang menyeluruh bagi penderita penyakit degeneratif seperti stroke, Alzheimer, diabetes melitus, Parkinson maupun gagal jantung dan degenerasi ovarium. Stem cell merupakan sel yang mempunyai beberapa keunikan sehingga membuatnya berbeda dengan sel-sel lain yang menyusun tubuh. Keunikan dan karakteristik stem cell yang bersifat multipoten ataupun pluripotent merupakan harapan yang sangat menakjubkan berupa tersedianya terapi medis bagi para penderita penyakit degeneratif (Halim, dkk., 2010).

Stem cell mempunyai potensi terbaik untuk banyak tipe diferensiasi sel dan mempunyai potensi total untuk meregenerasi dari jaringan rusak yang disebabkan oleh penyakit atau injury. Upaya mobilisasi dan diferensiasi stem cell mampu meregenerasi sel-

sel pada jaringan atau organ dari pasien penderita penyakit dengan kondisi medical degeneratif. Ide ini “regenerative medicine” meningkatkan harapan jutaan pasien dengan penyakit degeneratif dan injury, dimana pengertian regenerasi dari kerusakan jaringan karena penyakit atau injury oleh sel-sel yang normal. Perbaikan organ dan jaringan yang rusak melalui mobilisasi dan differensiasi stem cell dapat secara potensial pada bagian yang dibutuhkan oleh pasien, meliputi sebagian besar kasus kematian dalam suatu negara (Rantam et al., 2009).

Terkait dengan hakikatnya, saat ini stem cell saat ini telah menjadi topik utama pembicaraan banyak sientis, ahli dibidang medis bahkan orang awam diseluruh dunia, dikarenakan stem cell dipercaya menjadi jalan keluar dari berbagai penyakit degeneratif. Seperti telah diketahui, penyebab terjadinya penyakit degeneratif adalah kerusakan sel dalam jaringan atau organ, sehingga jaringan atau organ tersebut tidak lagi berfungsi sesuai dengan kebutuhan tubuh. Kerusakan ini bersifat irreversible, sehingga obat-obatan yang pada saat ini tersedia, hanya dapat memperlambat atau mencegah terjadinya kerusakan jaringan atau organ yang lebih luas dan tidak dapat diperbaiki lagi, satu-satunya jalan yang harus ditempuh adalah adalah mengganti komponen organ atau jaringan yang rusak tersebut dengan organ atau jaringan yang baru yang masih berfungsi optimal. Atas dasar pemikiran inilah para ahli berpikir bahwa stem cell adalah tumpuan terapi kedokteran di masa yang akan datang (Fodor, 2003; Kaczmarczyk, 2008 and Lindvall and Kokaia, 2004).

Stem cell bersifat pluripoten bila mampu berdiferensiasi menjadi sel tubuh apapun, yaitu yang berasal dari ketiga lapisan embrional (ektoderm, mesoderm, dan endoderm); dan stem cell bersifat multipoten bila hanya mampu berdiferensiasi menjadi beberapa jenis sel, yang biasanya berada dalam suatu golongan serupa, seperti sel-sel sistem hematopeitik ataupun sistem syaraf.

Proses diferensiasi stem cell diduga disebabkan oleh faktor internal maupun faktor eksternal sel. Faktor internal sel mencakup faktor genetik dan epigenetik, sedangkan faktor eksternal sel mencakup kondisi lingkungan sekitar sel, faktor pertumbuhan (growth faktor), ataupun bergantung pada kebutuhan jaringan/ organ tubuh itu sendiri. Hingga saat ini, faktor-faktor yang menentukan terjadinya diferensiasi dari stem cell terus diteliti.

Berdasarkan tingkat maturasi tubuh yang menjadi sumber keberadaannya, secara praktis stem cell dibagi menjadi dua jenis, yaitu stem cell embrionik (embryonic stem cell/ ESC) dan stem cell dewasa (adult stem cell). Stem cell embrionik adalah stem cell yang didapatkan saat perkembangan individu masih berada dalam tahap embrio. Lebih tepatnya, stem cell ini adalah massa sel dalam (inner cell mass) yang terdapat dalam blastosis. Inner



cell massterbentuk saat embrio berusia 3-5 hari, yaitu saat blastosis terbentuk dan akan mengimplementasikan dirinya ke dalam dinding rahim. Tahap perkembangan selanjutnya, sel-sel ini akan berdiferensiasi menjadi sel-sel yang lebih dewasa, yang memiliki kemampuan proliferasi dan diferensiasi yang lebih rendah dibandingkan stem cell embrionik.

Stem sel embrionik merupakan awal dari seluruh jenis sel dalam tubuh manusia. Stem cell embrionik tergolong sebagai stem cell yang bersifat pluripoten. Inilah keistimewaan stem cell embrionik yang sulit disaingi oleh stem cell jenis lain. Dengan dasar sifatnya yang pluripoten, secara logis, tidak ada satupun penyakit degeneratif yang tidak dapat diobati. Berbagai riset yang telah dipublikasikan hingga saat ini, baik in vivo maupun in vitro, menunjukkan hasil yang mendukung optimisme ini (Odorico et al., dan Wobus and Boheler, 2005). Selain sifatnya yang pluripoten, stem cell embrionik juga memiliki daya proliferasi yang tinggi, telomer yang panjang, dan aktivitas enzim telomerase yang tinggi. Karena hal ini juga, terapi sel dengan menggunakan stem cell embrionik menyebabkan resiko tinggi terjadinya proliferasi sel yang berlebih, sehingga berujung pada terjadinya pembentukan tumor yang tidak diinginkan (Pera et al., 2000).

### **BAB 3. TUJUAN DAN MANFAAT PENELITIAN**

#### **Tujuan Penelitian :**

Tujuan dari penelitian ini adalah mendapatkan stem cells yang bersifat pluripotent dan tanpa disertai proses mutasi gen. Melalui pemberian low oksigen tension diharapkan akan terjadi proses induce pluripotent stem cells (iPS), sehingga stem cells yang dikultur dapat dikembangkan dan berdeferensiasi menjadi berbagai macam jenis sel baik mesoderm, endoderm maupun ektoderm. Lebih lanjut, pemberian low oksigen tension pada saat kultur in vitro juga dapat mengatasi problem yang selama ini terjadi seperti rendahnya viabilitas baik pada saat ditransplantasikan, berupa pembentukan senescence cells (Tsai et al., 2011), dan apoptosis (Wang et al., 2008) serta perubahan mutasi gen setelah ditransplantasikan (Szablowska-Gadomska et al., 2011) maupun sebelum ditransplantasikan (Safitri, 2014).

#### **Manfaat Penelitian**

Manfaat penelitian ini adalah ketersediaan bank stem cells yang bersumber dari adult stem cells (ASCs) namun bersifat pluripotent layaknya embrional stem cells (ESCs), sehingga dapat digunakan untuk transplantasi berbagai jenis sel di seluruh tubuh yang dibutuhkan. Hal ini perlu diupayakan dikarenakan ESCs dianggap tidak memenuhi kode etik



dalam program transplantasi sel pada human. Pada penelitian ini sumber ASCs yang digunakan adalah berasal dari rabbit-adiposit mesenchymal stem cells (r-AMSCc). Lebih lanjut stem cells yang diproduksi selain bersifat pluripotent juga tanpa disertai proses mutasi gen. Selanjutnya dari hasil penelitian ini dapat memberikan informasi ilmiah bahwa program iPS diduga dapat dilakukan TANPA pemanfaatan penyisipan faktor-faktor transkripsi berbagai vektor virus yang mempunyai banyak kelemahan seperti yang telah disebutkan pada latar belakang.

## BAB 4. METODE PENELITIAN

### 4.1. Isolasi r-AMSCs metode Liposuction

Presedur diawali dengan aspirasi dari jaringan adipose yang didapatkan dari sedot lemak (liposuction aspirate) pada daerah peritoneum dari rabbit strain new Zealand, kemudian dilakukan pencucian dan pemisahan campuran cairan perut, darah dan lemak bebas. Pemisahan secara spesifik menggunakan corong separator steril (autoclave). Pencucian dengan saline steril yang dipanaskan pada suhu 37°C diulang sampai jernih dan corong dibalik 4-5 menit dan ditutup, Selanjutnya posisi kembali ditegakkan dan ditunggu 3-5 menit untuk fase separation. Selanjutnya dilakukan tissue digestion: disiapkan volume yang sama banyak, saline buffer steril yang hangat, berisi 500 CDU/ ml (equivalent dg 0,5 Wunsch units/ ml) collagenase. Kemudian dituangkan washed fat dari corong sparatory dalam sebuah botol steril (volume tabung 4 x aspirate). Lebih lanjut ditambahkan saline buffer/ campuran collagenase, tutup tabung dan letakkan pada shaker hangat, prewarmed 35-38°C selama 20±5 min, frequency dan amplitude dari shaking akan diset sedemikian rupa, sehingga cukup untuk mencegah pemisahan jaringan adipose yang mengapung dari cairan collagenase. Setelah lengkap, digestion dipindahkan pada sebuah glass corong sparasi sterile, dibiarkan terjadi solution selama 5-10 menit agar terjadi fase separasi. Tahap berikutnya stopcock dibuka dan ditransfer seluruh fraksi yang tidak mengapung melalui filter 265 mm steril dan dimasukkan dalam beaker steril. Selanjutnya aliquot dari solution yang tidak mengapung dikoleksi dalam gelas beaker dan dimasukkan dalam tabung setrifuse sebanyak 50 ml dan disentrifuse pada 400 g selama 5 menit pada suhu kamar dengan kecepatan low-medium. Kemudian pelan-pelan tuangkan supernatant aspirate (top layer) dalam tabung buangan tanpa mengganggu pellet dari sel. Terakhir suspensidising pada saringan sel 100 mm dan dikoleksi dalam tabung steril.



AYAH  
PANGRANGGEM  
KAWALANIN CANTINER  
AYAH AYAH

#### 4.2. Kultur in Vitro r-AMSCs pada Kondisi Low Oksigen Tension & Normoksia

Dilakukan sentrifugasi, kemudian aspirasi supernatant dan suspensi sel dalam 100  $\mu$ l inokulasi stromal medium sel dalam plate sampai sejumlah sekitar 500 mg adipose tissue, kemudian ditambahkan sejumlah volume stromal medium. 72 jam setelah plating, aspirate dimasukkan dalam medium. Selanjutnya sel dicuci dengan prewarmed PBS (1% antibiotic ditambahkan dalam solution) dengan pipeting naik dan turunkan untuk membersihkan sel secara perlahan dari fragment tissue dan atau sel darah. Kemudian ditambahkan sejumlah volume fresh stromal medium disesuaikan kapasitas well dari culture plate. Medium selanjutnya diganti setiap 2-3 hari sampai sel terbentuk confluence. Ketika sel sudah confluence 80-90% dilakukan panen sel. Pertama-tama medium dari well dihilangkan dan disimpan dalam kondisi media steril dalam sebuah tabung steril untuk aplikasi kultur sel selanjutnya (dilakukan penyaringan steril sebelum digunakan). Kemudian ditambahkan sedikit volume (250-500  $\mu$ l) pada PBS hangat steril pada well dan biarkan PBS berada di atas sel selama 2 menit. Selanjutnya dilakukan pengulangan PBS dengan 500  $\mu$ l Trypsin/ EDTA solution (0,5%) dan diinkubasi dalam incubator selama 5-10 menit. Verifikasi di bawah mikroskop yang lebih dari 90% sel telah terlepas dan kemudian ditambahkan 500 $\mu$ l stromal medium untuk dibiarkan terisi serum dalam larutan untuk netralisasi reaksi trypsin. Transfer medium berisi suspensi sel dari well ke dalam sebuah tabung steril. Disentrifugasi pada 300 gselama 5 menit. Aspirate supernatant dan suspensi sel dalam sejumlah sedikit volume stromal medium. Selanjutnya dilakukan proses counting (penghitungan) dengan menggunakan sebuah aliquot dilusi sel dalam trypsin blue (untuk a 1:8 dilution: ditambahkan 12,5  $\mu$ l pada suspensi sel sampai 87,5  $\mu$ l trypan blue). Penghitungan sel menggunakan hemacytomoter. Setelah penghitungan, sel dapat ditempatkan kembali berdasarkan kapasitas dalam culture plate sel yang sesuai.

#### 4.3. Observasi secara Flowcytometri

Flow Cytometri adalah sebuah teknik yang dilakukan untuk menghitung, memeriksa ekspresi dan memisahkan partikel yang melayang dalam sebuah cairan secara mikroskopis. Pada penelitian ini, metoda Flowcytometry ini digunakan selain untuk melihat ekspresi, juga untuk menghitung jumlah atau prosentasi keberadaan CD44+, CD 90+, CD34-, dan CD45-. Identifikasi tersebut dilakukan dengan cara menghitung protein dalam sebuah larutan yang diinjeksikan ke dalam alat Flow Cytometry (Facs Calibur-BD dengan program cellquest computerize), selanjutnya partikel-partikel secara acak terdistribusi dalam ruang

tiga dimensi. Sampel harus berada dalam sebuah aliran dari single partikel sehingga dapat dideteksi oleh sistem mesin. Proses ini diatur oleh sistem pengaliran. Setelah hydrodynamics terpusat, masing-masing partikel terdorong sampai pada satu atau lebih cahaya. Cahaya berpendar berupa pancaran fluorescence ketika partikel dilabel fluorochrom (FITC, PE, APC atau PerCP-Cy5.5). Pada penelitian ini digunakan beberapa antibody polyclonal seperti: Rabbit Anti-CD44/HCAM/PGPI Polyclonal Antibody, PE conjugated Conjugated Primary Antibodies (bs-0521R-PE, Biossusa).

#### **4.4. Karakterisasi secara Imunfluorescence**

Marker r-AMSCs dapat diidentifikasi dengan menggunakan Imunofluorescence indirect. Identifikasi tersebut dilakukan dengan cara kultur sel AMSCs dipanen kemudian dimasukkan ke dalam tube 15 ml dan difiksasi dengan menggunakan metanol, setelah 15 menit ditambahkan reagen anti sel dari marker yang dikarakterisasi (CD44+, CD45-, OCT4 dan SOX2). Marker tersebut dilabel FITC, kemudian dicuci dengan PBS lalu diteteskan pada obyek gelas dan dianalisa di bawah mikroskop fluorescence (Rantam et al., 2008).

#### **4.5. Observasi CFU-Fs**

Observasi jumlah koloni like CFU-Fs pada sel yang dikultur diamati dengan menggunakan mikroskop inverted untuk menghitung jumlah koloni like CFU-Fs yang terbentuk. Semakin sedikit jumlah koloni semakin besar ukurannya, begitu pula sebaliknya semakin banyak jumlah koloni semakin kecil ukuran koloni yang terbentuk.

#### **4.6. PCR OCT4, SOX2, CD44**

Prinsip PCR terdiri atas tiga tahap, yaitu denaturasi untai ganda DNA, selanjutnya annealing (penempelan) primer pada DNA targetnya, terakhir primer extension (pemanjangan primer) dengan adanya DNA polymerase. Hasil DNA yang terjadi merupakan akumulasi eksponensial dari DNA target yang spesifik. Ada 3 tahapan dalam tahap amplifikasi ini yaitu tahapan denaturasi yang dilakukan dengan menginkubasi pada waterbath dengan suhu 95°C, tahap annealing yaitu proses penempelan primer pada template dilakukan pada suhu 50°C, tahap akhir yaitu tahap ekstensi, yaitu proses pemanjangan untai basa nukleotida pada suhu 70°C sehingga terbentuk 2 untai ganda DNA baru (Purwati et al., 2009). Analisis produk PCR : produk PCR cDNA yang telah diamplifikasi selanjutnya divisualisasikan dengan elektroforesis menggunakan pewarnaan ethidium

bromide. Konsentrasi agarose yang digunakan adalah 25% produk PCR ini selanjutnya dilakukan sekuensing.

#### 4.7. Sekuensing DNA OCT4, SOX2, CD44

Tahapan sekuensing DNA ini meliputi : Purifikasi produk PCR: yaitu satu volume hasil PCR ditambahkan 5 volume PBS, kemudian ditambahkan 10  $\mu$ l sodium asetat 3 M pH 5, selanjutnya sebagai pengikat DNA, sampel diletakkan pada QIA quick column dan disentrifugasi dengan kecepatan 13.000 rpm selama 1 menit. Supernatan hasil sentrifugasi kemudian dibuang. Setelah itu ditambahkan 75  $\mu$ l buffer PE dan disentrifugasi dengan kecepatan 13.000 rpm selama 1 menit. Supernatan dibuang lalu disentrifugasi lagi selama 1 menit pada kecepatan 14.000 rpm. QIA quick column diletakkan pada tube ependorf 1,5 ml kemudian ditambahkan 30  $\mu$ l buffer EB tepat ditengah-tengah column dan disentrifugasi dengan 75  $\mu$ l buffer PE selama 1 menit. Supernatan lalu dipindahkan ke tabung baru. Selanjutnya dilakukan Labelling : dengan cara dibuat campuran reagen yang terdiri dari 4 ml AmpliTag FNA polymerase, sequencing buffer, DNTPS, dye labeled terminators, 21  $\mu$ l produk PCR hasil purifikasi, 1,5  $\mu$ l primer dan ditambahkan ddH<sub>2</sub>O hingga mencapai volume 15  $\mu$ l, kemudian divortex. Tahap berikutnya dilakukan Presipitasi : pada produk hasil sekuensing sebanyak 15  $\mu$ l ditambahkan masing-masing 1,5  $\mu$ l EDTA, 125 Mm pH 8, 1,5  $\mu$ l sodium asetat 3M pH 2,5 dan 37,5  $\mu$ l ethanol absolut kemudian divortex dan diinkubasi pada suhu 4°C. Sampel dibungkus menggunakan aluminium foil agar terhindar dari cahaya dan disimpan di dalam lemari pendingin dengan suhu -20°C. Selanjutnya dilakukan Sekuensing : dimana urutan basa DNA dapat ditentukan dengan mengurutkan fragmen yang muncul dimulai dari yang paling bawah (paling pendek). Alat yang digunakan adalah ABI 3110 XI Capillary Sequencer. Fragmen DNA dapat divisualisasi karena primer yang digunakan dilabel dengan fluoresses. Hasil sekuensing berupa elektroforegram. Tahap akhir merupakan Analisis software hasil sekuensing menggunakan Bioedit, BLAST (Basic Local Alignment Search Tool) dan clustalV : analisis hasil Bioedit yaitu program Sequence Alignment Editor yang bertujuan untuk menganalisa bioinformatika terhadap sekuens DNA, RNA maupun protein. Salah satu tahapannya yaitu sequence alignment untuk hasil pembacaan sekuens suatu fragmen DNA yang dibaca secara dua arah (forward-reverse) (Hall and Ziedonis, 2007).

#### 4.8. Analisis Penyejajaran sekuens gen OCT4, SOX2, CD44

Sekuens yang diperoleh dari hasil penelitian dapat dianalisis dengan membandingkan data yang telah tersedia yang sudah dipublikasikan di Gene Bank database. Salah satu bentuk

analisis yang dapat dilakukan misalnya dengan analisis penyejajaran(sequence alignment). Analisis penyejajaran dapat digunakan untuk membandingkan 2 sekuens atau lebih sehingga dapat mudah terlihat letak perbedaan basa. Program yang digunakan untuk analisis penyejajaran yaitu Bioedit dan BLAST. Fungsi dari program ini untuk menganalisa data sekuens, membandingkan urutan sekuens yang diteliti dengan database berbagai strain yang berbeda dari berbagai negara dan untuk melihat kecocokan sampel dari urutan basanya (query confidence) (Thomson et al., 2002).

#### **4.9. Transplantasi pada Hewan Model Degenerative Testis**

Observasi terhadap Libido dan Fertilitas dengan Cara Dikawinkan secara Single Matting hAMSCs pada pasase ke-5 yang telah dipersiapkan dan ditumbuhkan di medium Dulbecco's dan FBS 15% dengan 100 U/ml penisilin-streptomisin (Gibco, Grand Island, NY) ditransplantasikan pada tikus sebagai hewan model degenerative testis. Penelitian dibagi menjadi 2 kelompok, masing-masing terdapat 10 ulangan, yaitu : 1. Kelompok Normoksia : Tikus jantan dengan degenerative testis ditransplantasi hAMSCs yang dikultur pada konsentrasi O<sub>2</sub> 21% 2. Kelompok Low O<sub>2</sub> tension: Tikus jantan dengan degenerative testis ditransplantasi hAMSCs yang dikultur pada konsentrasi O<sub>2</sub> 5% Selanjutnya dilakukan observasi terhadap libido dan tingkat fertilitas dengan cara dikawinkan secara single matting.

#### **4.10. Transplantasi pada Hewan Model Degenerative Ovarium**

Observasi terhadap Jumlah Embrio setelah Dikawinkan secara Single Matting hAMSCs pada pasase ke-5 yang telah dipersiapkan dan ditumbuhkan di medium Dulbecco's dan FBS 15% dengan 100 U/ml penisilin-streptomisin (Gibco, Grand Island, NY) ditransplantasikan pada tikus sebagai hewan model degenerative ovarium. Penelitian dibagi menjadi 2 kelompok, masing-masing terdapat 10 ulangan, yaitu : 1. Kelompok Normoksia : Tikus betina dengan degenerative ovarium ditransplantasi hAMSCs yang dikultur pada konsentrasi O<sub>2</sub> 21% 2. Kelompok Low O<sub>2</sub> tension: Tikus betina dengan degenerative ovarium ditransplantasi hAMSCs yang dikultur pada konsentrasi O<sub>2</sub> 5% Selanjutnya dilakukan observasi terhadap jumlah embrio setelah dikawinkan secara single matting.

#### **4.11. Observasi secara Immunohistokimia (IHC)**

Prinsip teknik imunohistokimia merupakan perpaduan dari dua macam reaksi, reaksi imunologis dan reaksi kimiawi (Sudiana, 2005), dimana reaksi imunologis ditandai adanya reaksi antara antigen dengan antibodi, dan reaksi kimiawi ditandai adanya reaksi antara

enzim dengan substrat. Reaksi imunohistokimia bersifat spesifik karena bahan yang dideteksi akan direaksikan dengan antibodi spesifik yang dilabel dengan suatu enzim. Untuk menandai reaksi enzimatik digunakan suatu indikator warna (chromogen) (Sudiana, 2005 ).

#### **4.12. Observasi Regenerasi Jaringan Testis & Ovarium**

Pemeriksaan histopatologis pada testis dan ovarium diawali dengan pembuatan preparat histologis. Selanjutnya dilakukan pemeriksaan menggunakan mikroskop cahaya dengan pembesaran 400 kali. Pengamatan regenerasi jaringan tubulus seminiferus dan jaringan ovarium didasarkan pada gambaran histologis yang ada.



## Alur Penelitian Tahun I

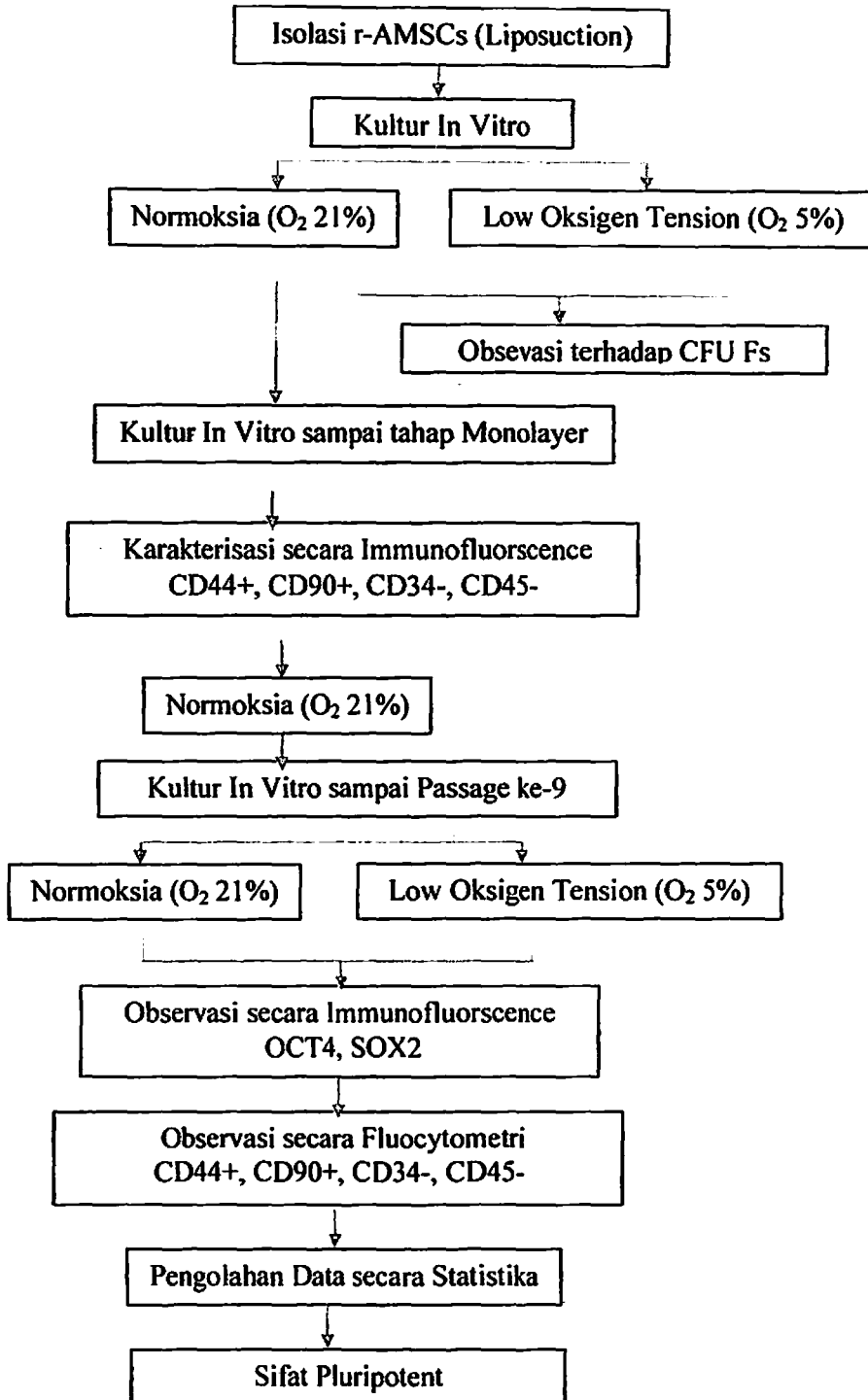

Alur Penelitian Tahun II (2018)

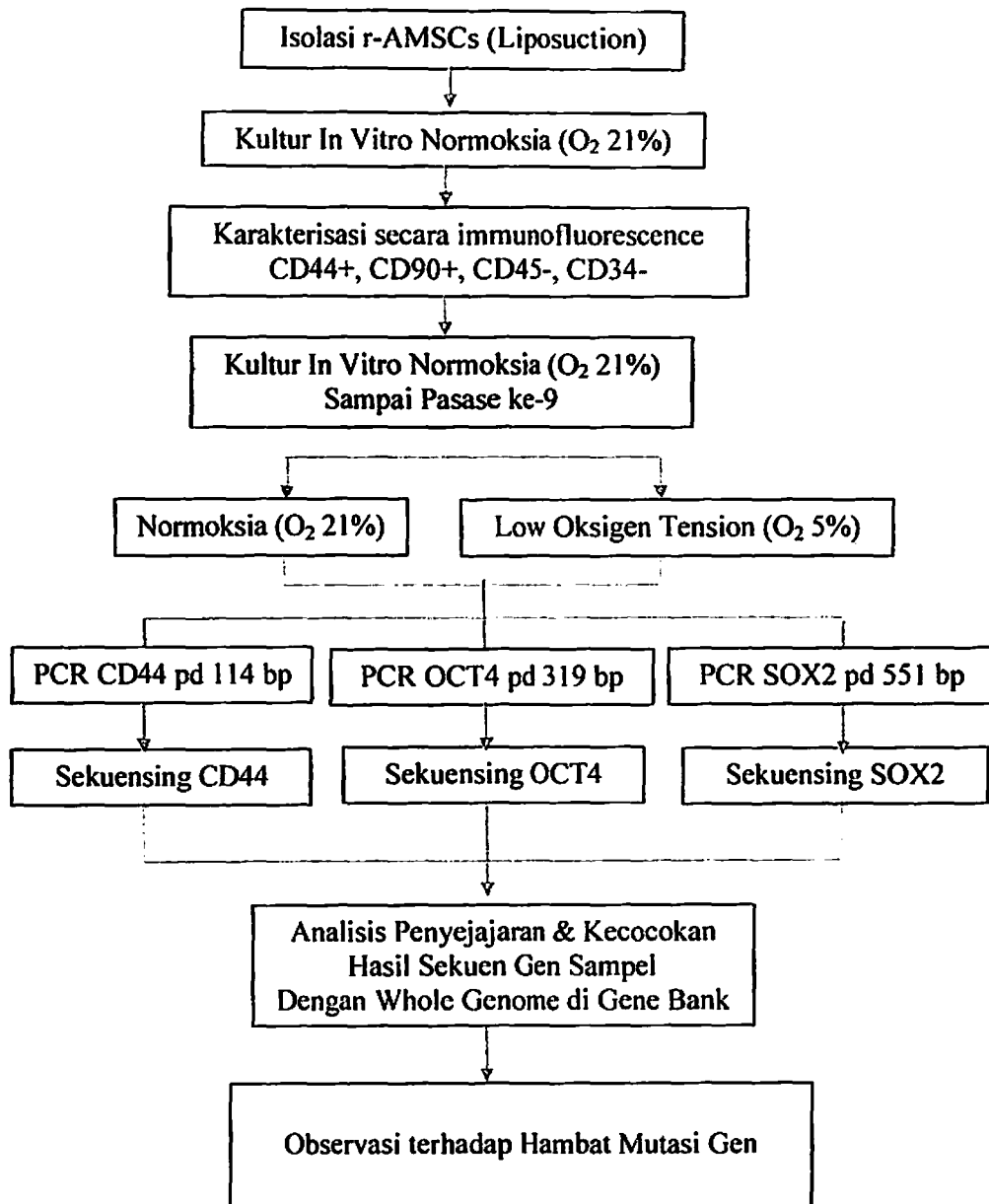

## BAB 5. HASIL DAN LUARAN YANG DICAPAI

### Isolasi r-AMSCs metode Liposuction

Telah dilakukan isolasi r-AMSCs melalui metode liposuction, prosedur diawali dengan aspirasi dari jaringan adipose yang didapatkan dari sedot lemak (liposuction aspirate) pada daerah peritoneum dari rabbit strain new Zealand, kemudian dilakukan pencucian dan pemisahan campuran cairan perut, darah dan lemak bebas (Gambar 1).

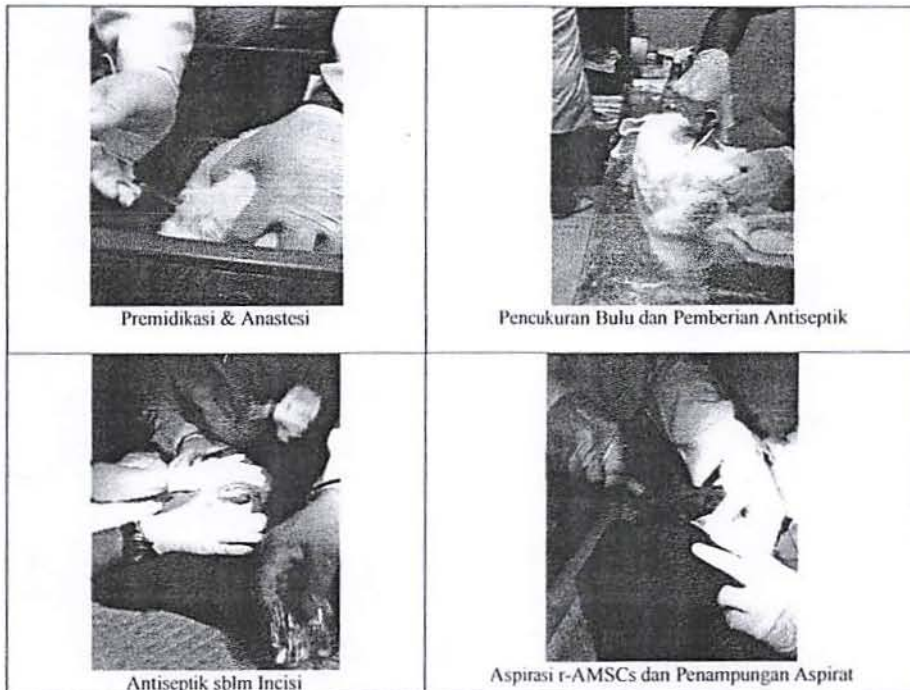

Gambar 1. Isolasi r-AMSCs metode Liposuction

### Kultur in Vitro r-AMSCs pada Kondisi Normoksia

Kultur in Vitro r-AMSCs pada Kondisi Normoksia dilakukan setelah isolat didapat, yang diawali dengan sistem sentrifugasi *ficoll gradient density* (Gambar 2). Selanjutnya dilakukan pemeriksaan mikroskopis (Gambar 3).



01118  
UNIVERSITAS AIRLANGGA  
JALAN KH. YUSUF KALYAN  
AYAH AYAH

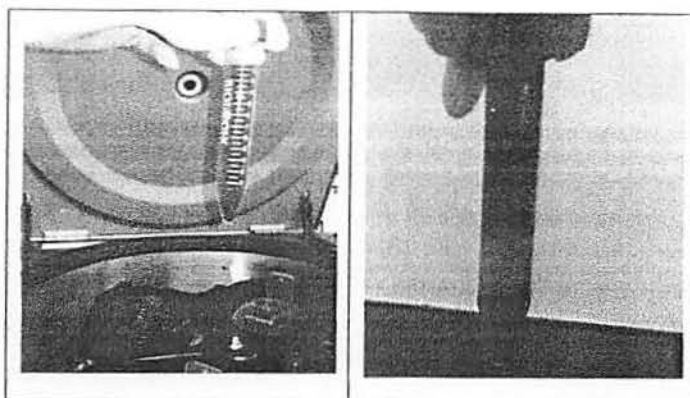

Gambar 2. Isolasi r-AMSCs dengan sistem sentrifugasi *ficoll gradient density*

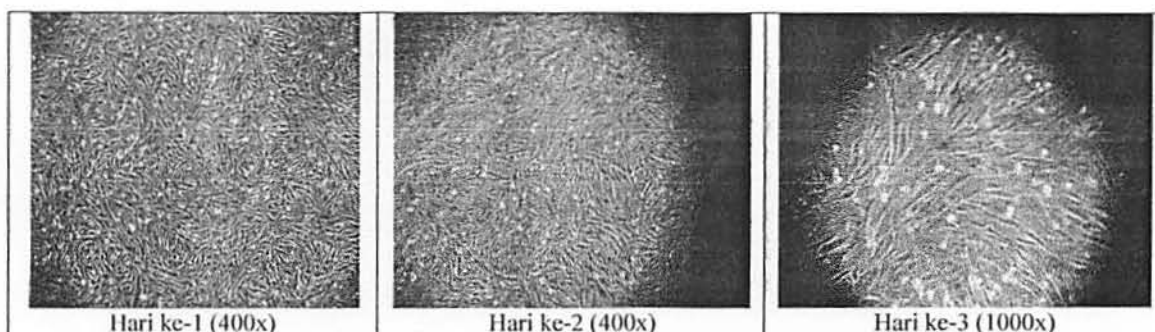

Gambar 3. Pemeriksaan mikroskopis dari kultur Normoksia pada hari ke-1 sampai ke-3

### **Kultur in Vitro r-AMSCs pada Kondisi Normoksia sampai Monolayer**

Kultur in Vitro r-AMSCs pada Kondisi Normoksia, observasi dimulai dari Mononucleated cells yang terkandung dalam buffy coat, kemudian diinkubasi 24 jam sampai MSCs melekat pada *petri dish* dan berbentuk bulat-bulat dilanjutkan sampai tahap monolayer. Medium selanjutnya diganti setiap 2-3 hari sampai sel terbentuk confluence. Ketika sel sudah confluence 80-90% dilakukan panen sel.

### **Karakterisasi secara Imunfluorescence**

Marker r-AMSCs dapat diidentifikasi dengan menggunakan Imunofluorescence indirect. Identifikasi tersebut dilakukan dengan cara kultur sel r-AMSCs dipanen kemudian dimasukkan ke dalam tube 15 ml dan difiksasi dengan menggunakan metanol, setelah 15 menit ditambahkan reagen anti sel dari marker yang dikarakterisasi, yaitu CD44+, CD90+, CD34-, CD45- (Gambar 4). Marker tersebut dilabel FITC, kemudian dicuci dengan PBS lalu ditetaskan pada obyek glas dan dianalisa di bawah mikroskop fluorescence (Rantam et al., 2008).

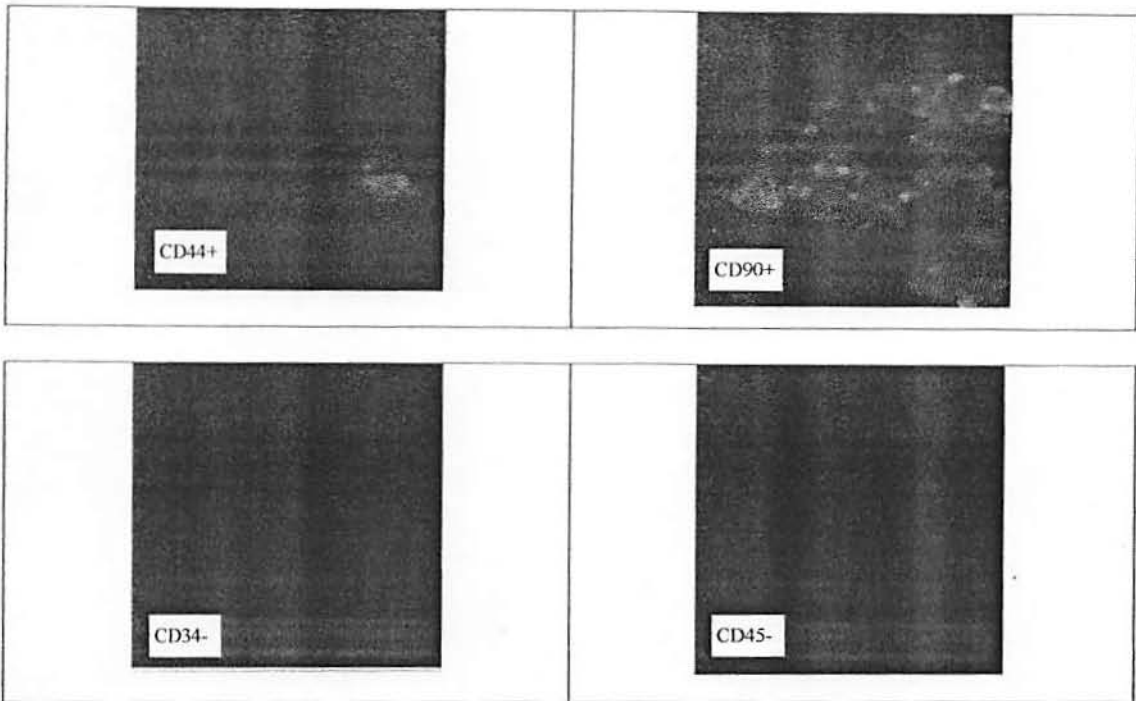

Gambar 4. Karakterisasi secara Imunfluorescence : CD44+, CD90+, CD34-, CD45-

#### **Kultur in Vitro r-AMSCs pada Kondisi Normoksia sampai Passage ke-9**

Kultur in Vitro r-AMSCs pada Kondisi Normoksia dilanjutkan sampai passage ke-9. Medium selanjutnya diganti setiap 2-3 hari sampai sel terbentuk confluence (80-90%) sebanyak 9x, selanjutnya dilakukan panen sel dan dibagi menjadi 2 untuk kondisi normoksia dan low O<sub>2</sub> tension.

#### **Karakterisasi secara Genotipe dari CD44, OCT4 dan SOX2 berdasarkan PCR**

Karakterisasi CD44, OCT4 dan SOX2 dari r-AMSCs secara genotype setelah perlakuan kondisi normoksia dan low O<sub>2</sub> tension ini dilakukan melalui metoda PCR dan *sequencing* DNA. Karakterisasi didasarkan pada *two step* PCR ini bertujuan untuk mendapatkan ekspresi gen pengkode CD44, OCT4 dan SOX2 yang tidak mengalami perubahan secara genetik setelah diberi perlakuan kondisi low O<sub>2</sub> tension. Hal ini menjadi dasar bahwa perlakuan low O<sub>2</sub> tension tidak menyebabkan terjadinya perubahan pada gen (mutasi gen), namun sebaliknya mutasi gen dapat terjadi jika kultur dibiarkan tetap pada kondisi normoksia. Didapatkan hasil PCR dari gen CD44 sebesar 551 *base pare (bp)* (Gambar 5), gen OCT4 sebesar 114 *bp* (Gambar 6) dan SOX2 sebesar 319 *bp* (Gambar 7).

Untaian cDNA yang tampak pada Gambar tersebut menunjukkan konsentrasi jumlah sel *r-AMSCs* yang cukup untuk mengekspresikan gen pengkode CD44, OCT4 serta SOX2. Selanjutnya dilakukan purifikasi dari hasil PCR, kemudian dilabeling dan disekuensing untuk mendapatkan susunan basa nukleotida gen pengkode CD44, OCT4 serta SOX2.

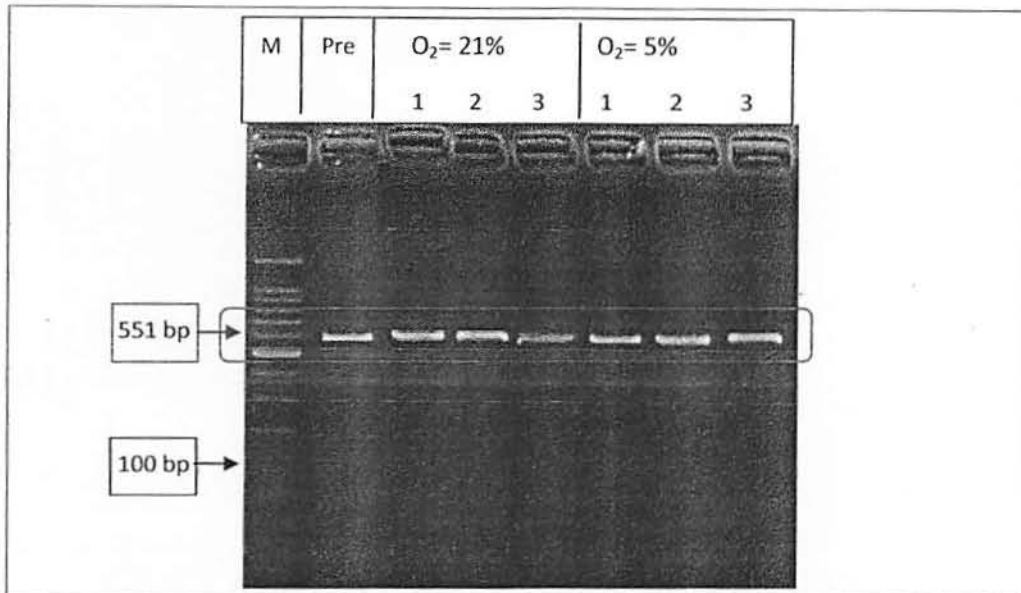

Gambar.5. Analisis gen pengkode CD44 dengan PCR setelah perlakuan kondisi low O<sub>2</sub> tension (O<sub>2</sub>=5%) dibandingkan dengan Normoksia (O<sub>2</sub>=21%) dan juga pre perlakuan, yang divisualisas secara elektroforesis pada gel agarose 2% pewarnaan ethidium bromide. Hasil menunjukkan untai cDNA sebesar 551 bp., M = Marker.

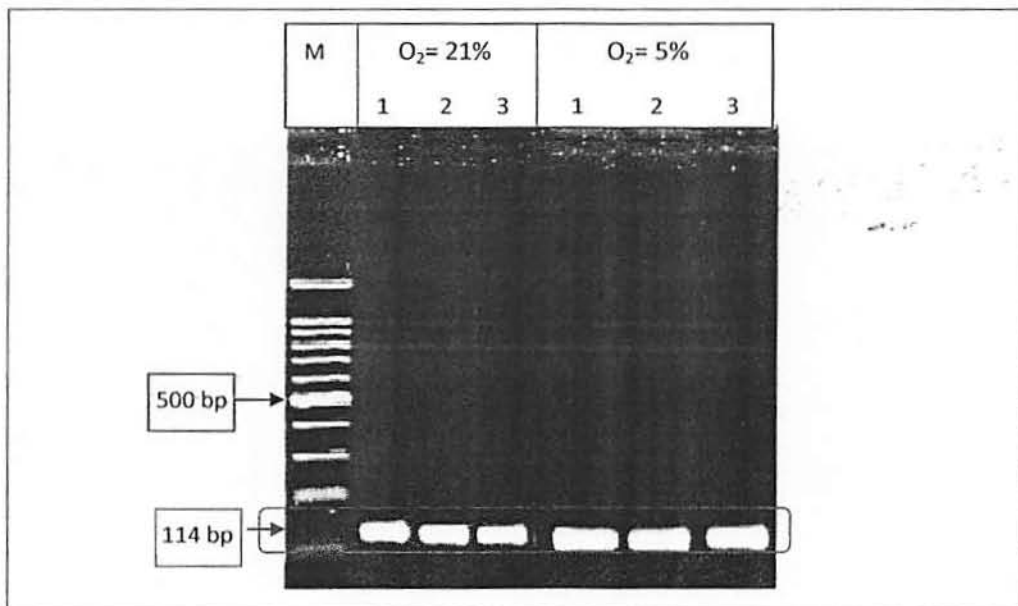

Gambar 6. Analisis gen pengkode OCT4 dengan PCR setelah perlakuan kondisi low oksigen tension (O<sub>2</sub>=5%) yang dibandingkan dengan normoksia (O<sub>2</sub> 21%) yang divisualisasikan secara elektroforesis pada gel

agarose 2% pewarnaan *ethidium bromide*. Hasil menunjukkan untaian cDNA sebesar 114 bp., M =Marker

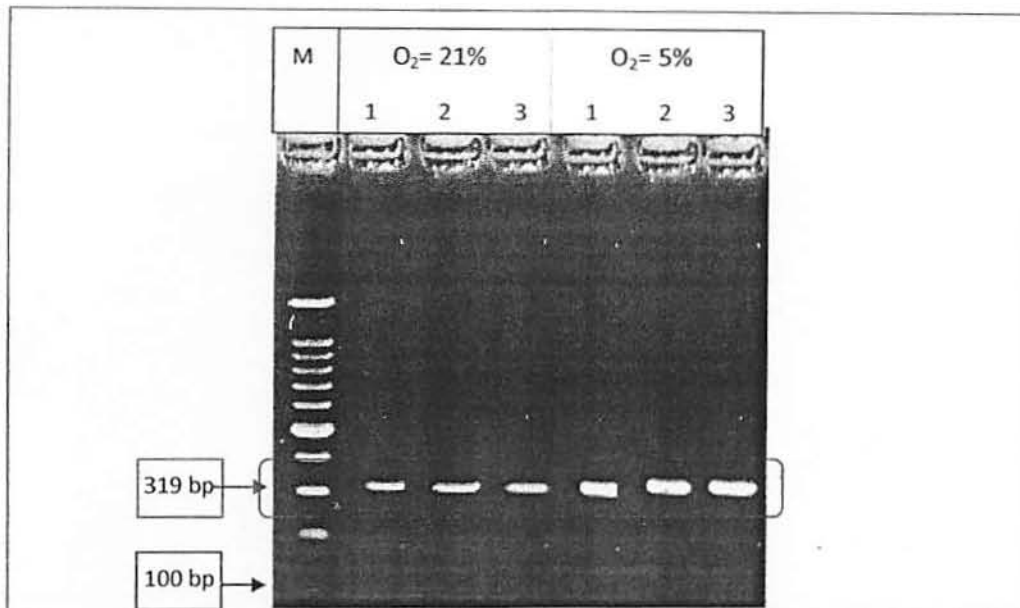

Gambar.7. Analisis gen pengkode SOX2 dengan PCR setelah perlakuan kondisi low oksigen tension (O<sub>2</sub>=5%) yang dibandingkan dengan normoksia (O<sub>2</sub>=21%) yang divisualisas secara elektroforesis pada gel agarose 2% pewarnaan *ethidium bromide*. Hasil menunjukkan untaian cDNA sebesar 319 bp., M =Marker

Untaian cDNA yang tampak pada kedua gambar di atas menunjukkan konsentrasi jumlah sel *MSCs* yang cukup untuk mengekspresikan gen pengkode OCT4 dan SOX2. Selanjutnya dilakukan purifikasi dari hasil PCR, kemudian dilabeling dan disekuensing untuk mendapatkan susunan basa nukleotida gen pengkode OCT4 dan SOX2.

#### Karakterisasi CD44, OCT dan SOX2 berdasarkan *Sequencing DNA*

*Sequencing DNA* akan menghasilkan sekuens DNA yang tergambaran melalui untaian huruf lambang nukleotida sebagai penyusun DNA seperti ATGC. Teknik *sequencing* ini menggunakan suatu metode yang dikenal dengan sebutan metode Sanger, yaitu suatu metode yang mempergunakan terminasi atau akhir reaksi sintesis DNA yang spesifik pada skuens tertentu dengan menggunakan nukleotida. Perpanjangan rantai DNA pada metode Sanger ini dimulai pada daerah spesifik pada template DNA dengan memanfaatkan primer. Primer tersebut akan komplementer dengan DNA dari sampel yang diobservasi.



Sequencing dilakukan untuk karakterisasi r-AMSCs secara *genotype* setelah r-AMSCs dikultur dengan kondisi normoksia dan low O<sub>2</sub> tension dengan tujuan untuk mendapatkan susunan basa nukleotida gen pengkode CD44, OCT4 an SOX2 yang diekspresikan oleh r-AMSCs. Hasil *sequencing* yang didapat dapat dilihat pada Gambar 8, 9 dan 10.

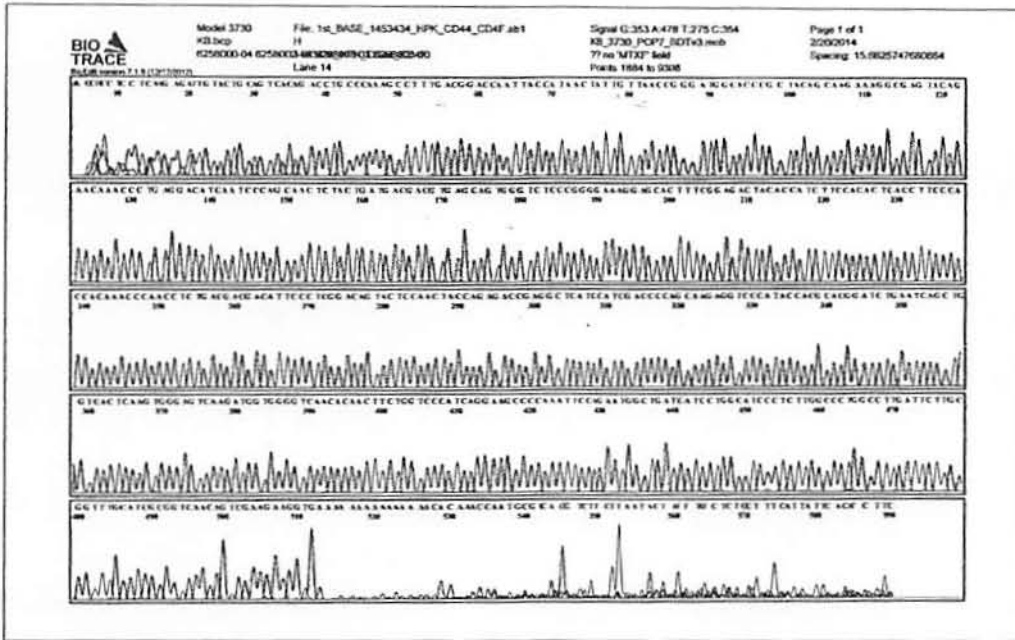

Gambar 8. Data raw *sequencing* susunan basa nukleotida gen pengkode CD44

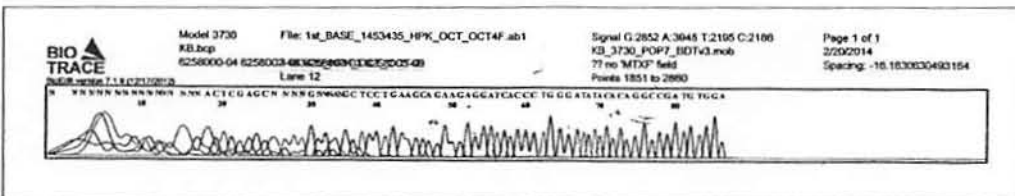

Gambar 9. Data raw *sequencing* susunan basa nukleotida gen pengkode OCT4

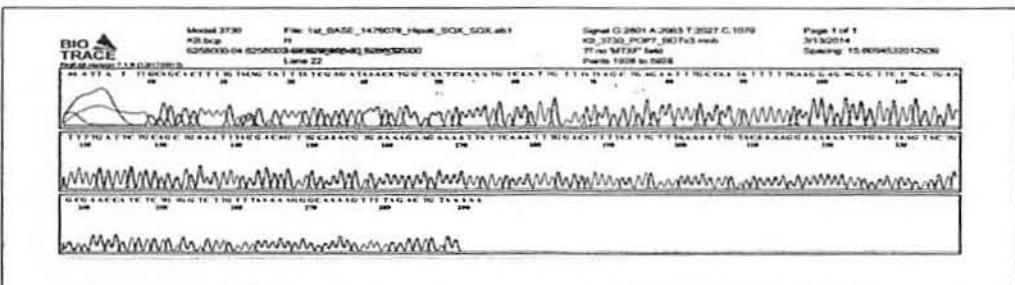

Gambar 10. Data raw *sequencing* susunan basa nukleotida gen pengkode SOX2

Hasil raw *sequencing* pada Gambar 8, 9 dan 10 merupakan visualisasi *elektroforegram* hasil *sequencing* dengan menggunakan primer CD44 (Oligo-Macrogen) dengan CD44f = 5'-TCC CAG TAT GAC ACA TAT TGC-3' (21mer) dan CD44r = '5-CAC CTT CTT CGA CTG TTG AC-3' (20mer), primer OCT4 (Oligo-Macrogen) dengan OCT4f = 5'-AGC AAA ACC CGG AGG AGT-3' (18mer) dan OCT4r = '5-CCA CAT CGG CCT GTG TAT ATC-3' (21mer) dan primer SOX2 (Oligo-Macrogen) dengan SOX2f = 5'-GCT AGT CTC CAA GCG ACG AA-3' (20mer) dan SOX2r = '5-AAG GGC AAA AGT TTT AGA CTG TA-3' (23mer).

Susunan basa nukleotida yang ditunjukkan pada *elektroforegram* hasil *sequencing* dari sampel setelah perlakuan prekondisi hipoksia menunjukkan bahwa basa yang disandi oleh primer OCT4 (Gambar 9) dan SOX2 (Gambar 10) tersebut menunjukkan bahwa DNA yang teramplifikasi memiliki kemurnian yang baik. Berdasarkan hasil amplifikasi tersebut, analisis hasil *sequencing* di atas dapat dilanjutkan dengan melakukan *Bioedit* menggunakan metode *Sequence Aligment Editor* dengan tujuan untuk menganalisa bioinformatika terhadap sekuens DNA, RNA maupun protein.

#### **Analisis Penyejajaran & Kecocokan Hasil Sekuen Gen Sampel Dengan Whole Genome di Gene Bank dan Observasi terhadap Hambat Mutasi Gen**

Rangkaian analisis *sequencing* dilakukan melalui beberapa tahap, yang diawali dengan *sequence aligment* (analisis penjajaran) yang bertujuan untuk membandingkan dua sekuens atau lebih sehingga dapat dengan mudah terlihat perbedaan basa. Tahap analisis penjajaran ini menggunakan suatu program khusus yaitu *Bioedit* dan *BLAST* (*Basic Local Aligment Search Tool*). Fungsi dari program ini adalah ditujukan untuk menganalisa data hasil sekuens, membandingkan urutan sekuens yang diteliti dengan database berbagai jenis faktor transkripsi yang berbeda dan untuk melihat kecocokan sampel dari urutan basanya

(query confidence). Hasil analisis sekuensing, analisis penyejajaran pada penelitian dan whole genom CD44 (Gambar 11 - 13); OCT4 (Gambar 14 - 16) dan SOX2 (17 - 19)

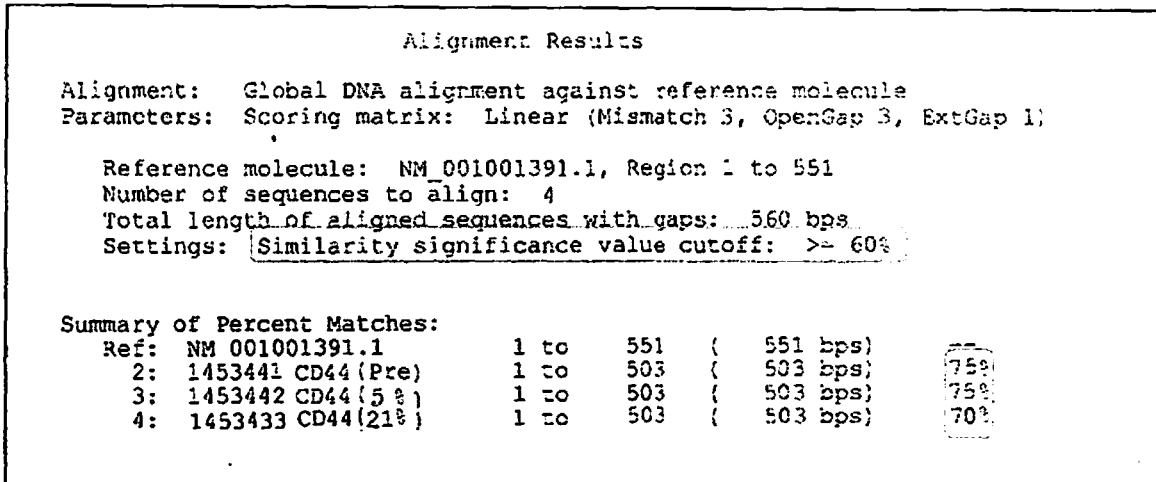

Gambar 11. Analisis penyejajaran didapatkan 3 data kecocokan hasil sekuens gen pengkode CD44 sampel dengan whole genom yang ada di gene bank ( $\geq 60\%$ )

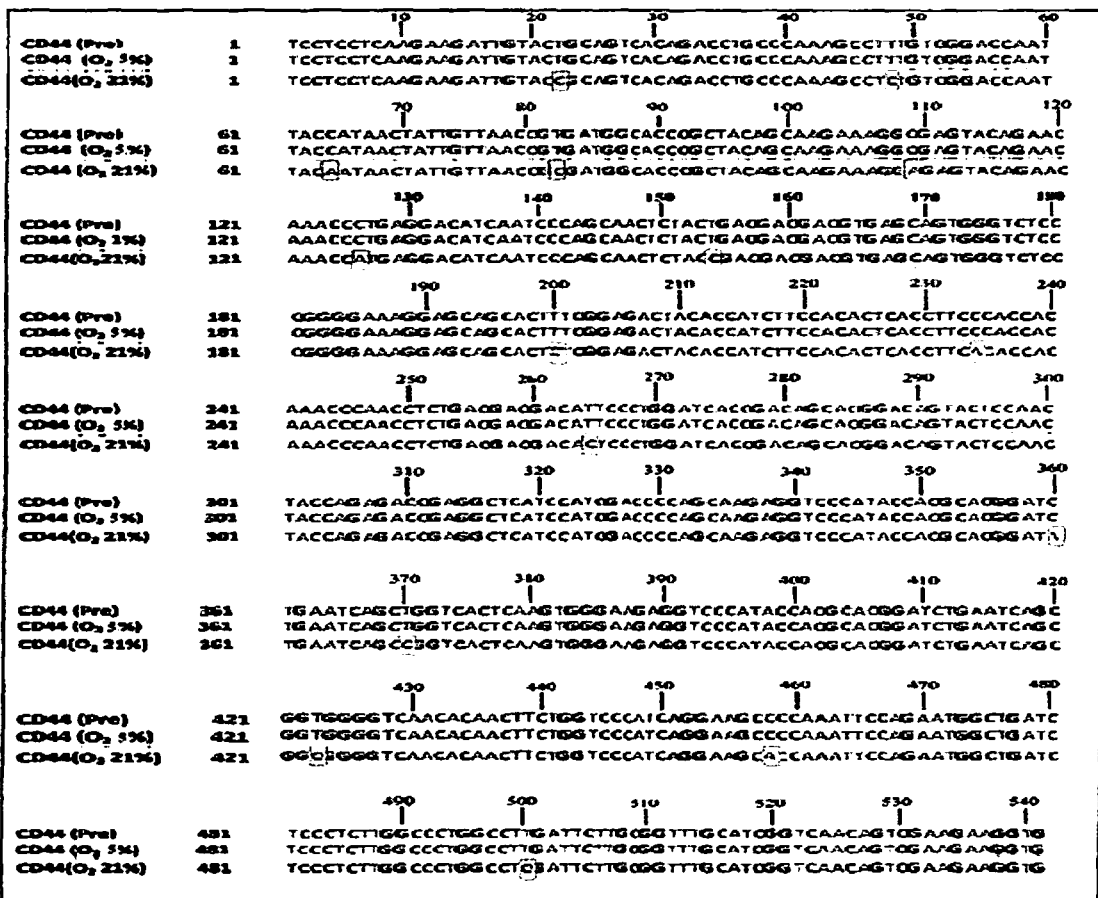

Gambar 12. Hasil analisis sekuensing CD 44 dengan menggunakan *multiple alignment* setelah perlakuan low oksigen tension.

```

TCCCAGTATGACACATATTGCTTCAATGCTTCAGCTCCACCTGAAGAAGATTGTACATCA
GTCACAGACCTGCCCAATGCCTTTGAT GGACCAATTACCATAACTATTGTAAACCGTGAT
GGCACCCGCTATGTCCAGAAAGGAGAATACAGAACGAATCCTGAAGACATCTACCCCAGC
AACCTACTGATGATGACGTGAGCAGCGGCTCCTCCAGTGAAAGGAGCAGCACTTCAGGA
GGTTACA --- TCTTTTACAC --- CTTTTCTACTGTACACCCCATCCCAGACGAAGCCAGT
CCCTGGATCACCGACAGCACAGACAGAATCCCTGCTACCAGAGACCAAGACACAT --TC
CACCCCAGTGGGGGGTCCCATAACCACTCATGGATCTGAATCAGATGGACACTCACATGGG
AGTCAAGAAGGTGGAGCAAACACAACCTCTGGTCCTATAAGGACACCCCAAATTCCAGAA
TGGCTGATCATCTTGGCATCCCTCTTGGCCTTGGCTTTGATTCTTGCAGTTTGCATTGCA
GTCAACAGTCGAAGAAGGTG

```

Gambar 13. Whole genom CD44

Berdasarkan analisis penyejajaran didapatkan 3 data kecocokan hasil sekuens gen pengkode CD44 sampel (pre, O<sub>2</sub> 5% dan O<sub>2</sub> 21%) dengan whole genom yang ada di gene bank (Gambar 13). Namun demikian, pada kultur normoksia (O<sub>2</sub> 21%) telah terjadi mutasi, yaitu T menjadi C pada nukleotida no 22, 47, 82, 154, 200, 264, 370, 423, 500 dan C menjadi A pada nukleotida no 63, 109, 126, 234, 360, 458 (Gambar 12).

Hasil analisis sekuensing, analisis penyejajaran dan whole genom OCT4 pada penelitian ini dapat dilihat pada Gambar 14 - 16.

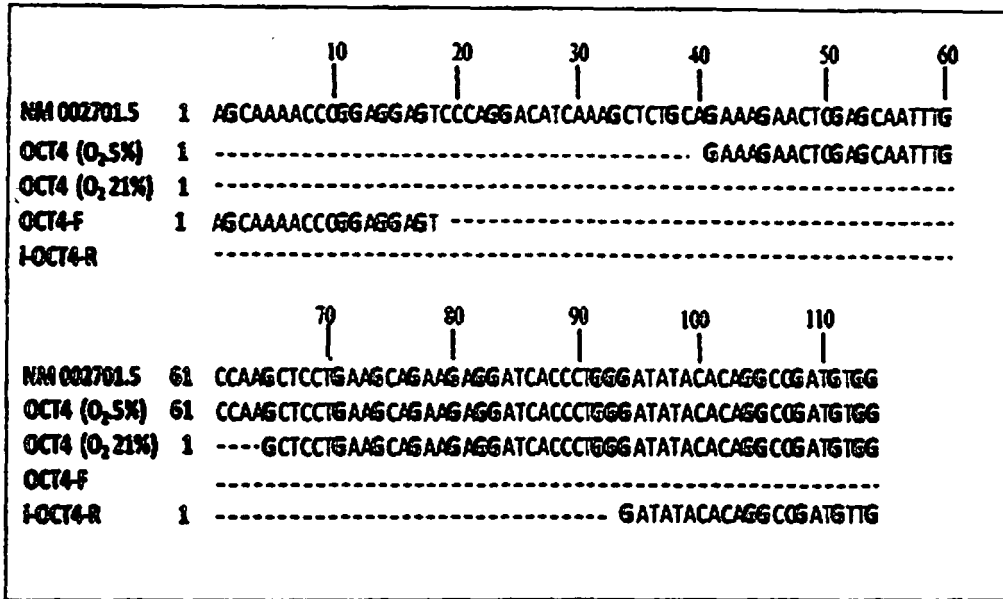

Gambar 14. Analisis sekuensing OCT4 menggunakan *multiple alignment*.

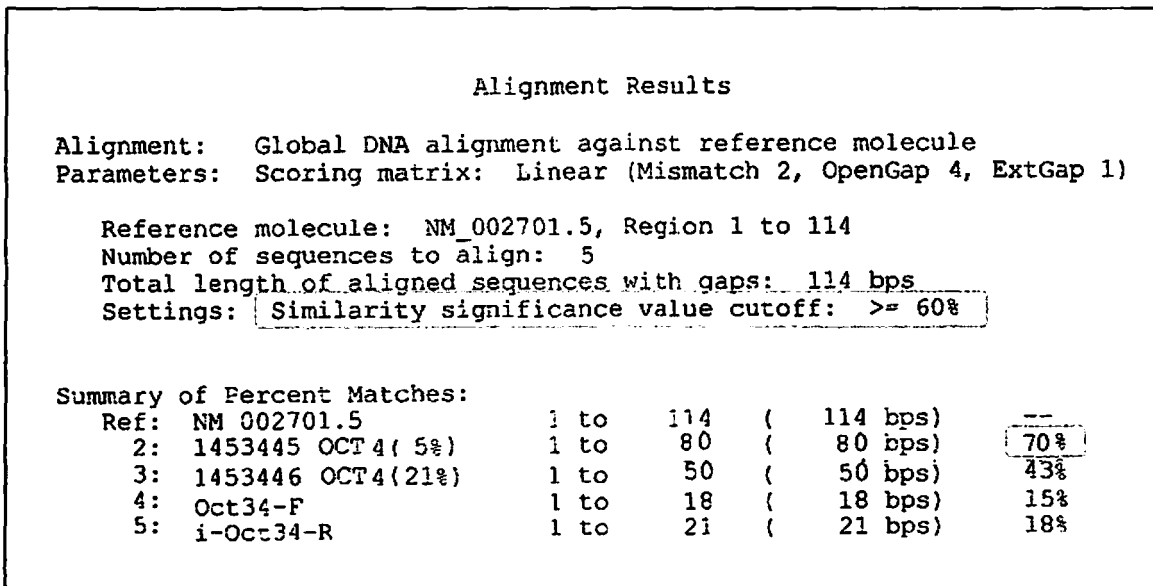

Gambar 15. Analisis penyejajaran didapatkan 1 data kecocokan hasil sekuens gen pengkode OCT4 sampel dengan perlakuan low O<sub>2</sub> tension 5% dengan whole genom di Gene Bank ( $\geq 60\%$ ).

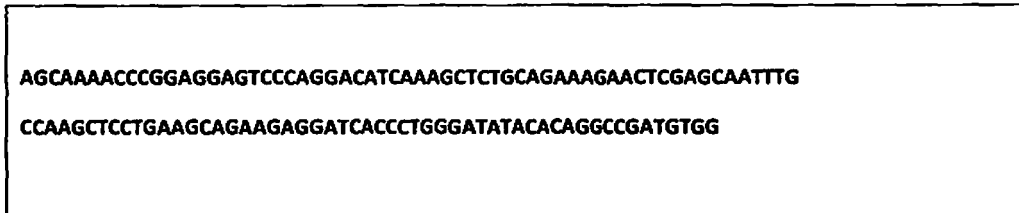

Gambar 16. Whole genom OCT4

Berdasarkan analisis gen pengkode OCT4 dengan PCR setelah perlakuan low O<sub>2</sub> tension (O<sub>2</sub> 5%) yang dibandingkan dengan normoksia (O<sub>2</sub> 21%) dan divisualisasikan secara elektroforesis pada gel agarose 2% dengan pewarnaan *ethidium bromide*, ketiga sampel menunjukkan untaian cDNA sebesar 114 bp. (Gambar 6). Namun demikian berdasarkan analisis penyejajaran hanya didapatkan 1 data kecocokan hasil sekuens gen pengkode OCT4 sampel dengan whole genom yang ada di gene bank (Gambar 16). Satu data yang cocok tersebut adalah pada sampel yang dikultur low O<sub>2</sub> tension (O<sub>2</sub> 5%). Kecocokan data didasarkan pada *similarity significance value cut of* yang harus  $\geq 60\%$  (70% pada kultur O<sub>2</sub> 5%), sedangkan pada kultur normoksia (O<sub>2</sub> 21%) *similarity significance value cut of*  $< 60\%$  (hanya 43%).

Hasil analisis sekuensing, analisis penyejajaran dan whole genom SOX2 pada penelitian ini dapat dilihat pada Gambar 17 - 19.

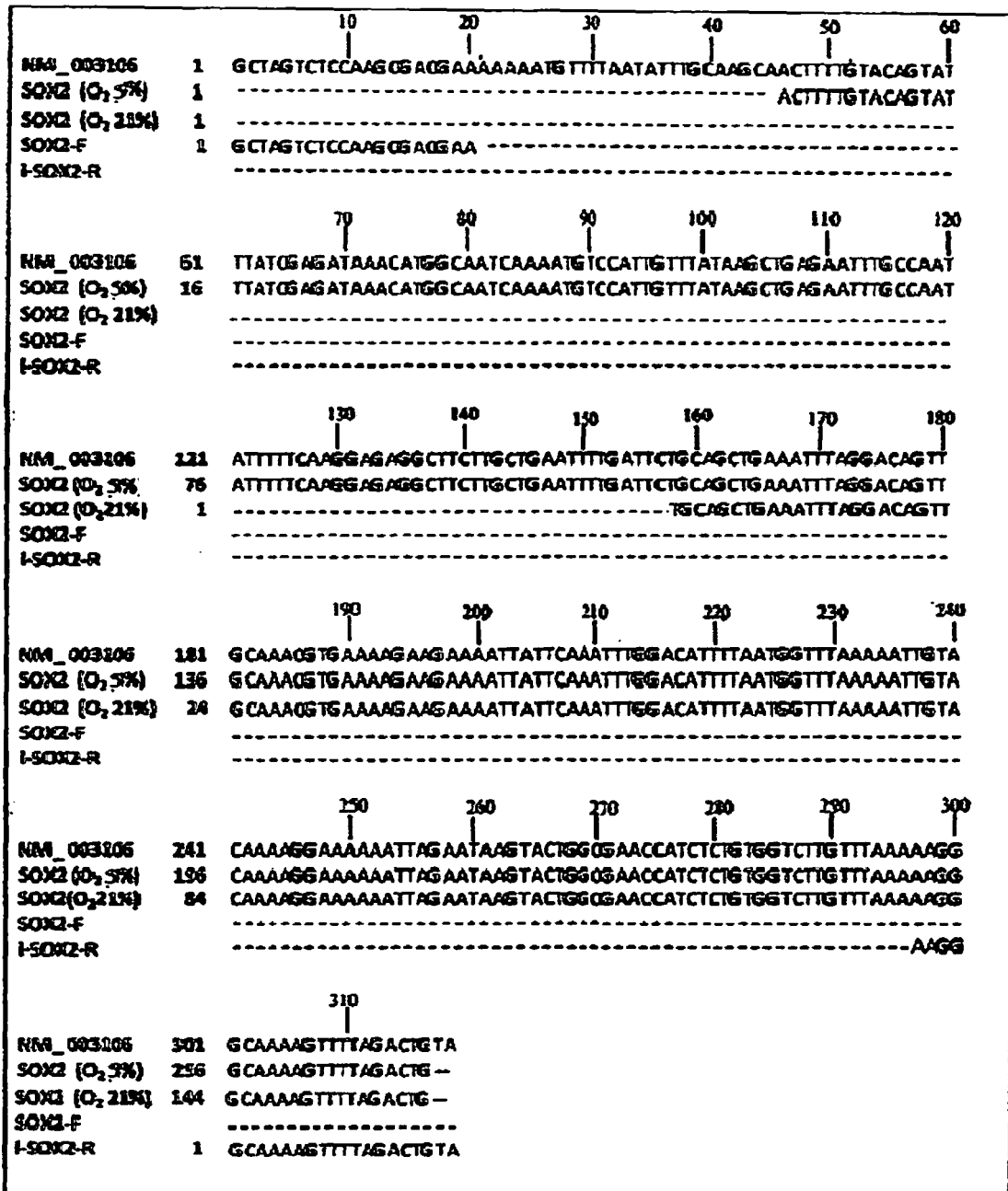

Gambar 17. Analisis sequencing SOX2 menggunakan multiple alignment.

Alignment Results				
Alignment: Global DNA alignment against reference molecule				
Parameters: Scoring matrix: Linear (Mismatch 2, OpenGap 4, ExtGap 1)				
Reference molecule: NM_003106, Region 1 to 319				
Number of sequences to align: 6				
Total length of aligned sequences with gaps: 319 bps				
Settings: Similarity significance value cutoff: $\geq 60\%$				
Summary of Percent Matches:				
Ref: NM_003106	1 to	319	( 319 bps)	--
2: SOX2 (5%)	1 to	250	( 250 bps)	78%
3: SOX2 (21%)	1 to	160	( 160 bps)	47%
4: Sox2-F	1 to	20	( 20 bps)	6%
5: i-Sox2-R	1 to	23	( 23 bps)	7%

Gambar 18. Analisis penyejajaran didapatkan 1 data kecocokan hasil sekuens gen pengkode SOX2 sampel dengan perlakuan lowOksigen tension ( $O_2=5\%$ ) dengan whole genom di Gene Bank ( $\geq 60\%$ ).

```

GCTAGTCTCCAAGCGACGAAAAAATGTTTAAATATTGCAAGCAACTTTTGTACAGTAT
TTATCGAGATAAACATGGCAATCAAATGTCCATTGTTTATAAGCTGAGAATTTGCCAAT
ATTTTTCAAGGAGAGGCTTCTTGCTGAATTTGATTCTGCAGCTGAAATTTAGGACAGTT
GCAAACGTGAAAAGAAGAAAATTATCAAATTTGGACATTTAATGGTTTAAAAATTGTA
CAAAGGAAAAAATTAGAATAAGTACTGGCGAACCATCTCTGTGGTCTTGTTTAAAAAGG
GCAAAAAGTTTTAGACTGTA

```

Gambar 19. Whole genom SOX2

Berdasarkan analisis gen pengkode SOX2 dengan PCR setelah perlakuan low oksigen tension ( $O_2 5\%$ ) yang dibandingkan dengan normoksia ( $O_2 21\%$ ) dan divisualisasikan secara elektroforesis pada gel agarose 2% dengan pewarnaan *ethidium bromide*, kedua sampel menunjukkan untaian cDNA sebesar 319 bp. (Gambar 7). Namun demikian berdasarkan analisis penyejajaran hanya didapatkan 1 data kecocokan hasil sekuens gen pengkode SOX2 sampel dengan whole genom yang ada di gene bank (Gambar 19). Satu data yang cocok tersebut adalah pada sampel yang dikultur low oksigen tension ( $O_2 5\%$ ). Kecocokan data



didasarkan pada *similarity significance value cut of* yang harus  $\geq 60\%$  (78% pada kultur  $O_2$  5%), sedangkan pada kultur normoksia ( $O_2$  21%) *similarity significance value cut of*  $< 60\%$  (= 47%).

### 5.1. Luaran Penelitian yang Dicapai

1. Mengikuti Seminar Internasional Symposium on Natural Medicine di Convention Center Bogor yang diadakan oleh Universitas IPB pada tanggal 24-25 Agustus 2017 sebagai pemakalah poster (Pada Tahun 1).
2. Mengikuti Seminar Internasional The 2<sup>nd</sup> Veterinary Medicine International Conference 2018 in Collaboration with ADPRC-OHCC yang diadakan oleh Faculty of Veterinary Medicine, Universitas Airlangga pada tanggal 4-5 July 2018 sebagai pemakalah Oral (Pada Tahun 2).
3. Accepted pada jurnal terindeks Scopus :
  - a. Biochemical and Cellular Archives, **ISSN : 09725075, Publisher : DR.P.R.YADAV**  
 Title : Hypoxic Precondition for Induce Pluripotency of Rabbit's Bone Marrow-Derived Mesenchymal Stem Cells
  - b. Veterinary World, **ISSN/EISSN : 0972-8988/2231-0916, Publisher : Veterinary World.**  
 Title : Quiescence cells, p63, which is regulated by hypoxia-inducible factor 2 $\alpha$ , very crucial for the function of spermatogonial stem cell to repair testicular failure and infertility
  - c. Philippine Journal of Veterinary Science  
 Title : Viability of Rabbit Adipocyte Stem Cells (r-ASCs) Cultured Under Different Oxygen Concentrations In Vitro

## BAB 6. RENCANA TAHAPAN BERIKUTNYA

Penelitian yang telah dilakukan pada tahun pertama (2017) telah terselesaikan 100%, yaitu isolasi, kultur dan karakterisasi dari Rabbit Adipocyte Mesenchymal Stem Cells (r-AMSCs) serta karakterisasi dari sifat pluripotent stem cells. Proses karakterisasi yang telah dilakukan berupa observasi terhadap marker penanda permukaan, seperti CD44+, CD90+, CD34- dan CD 45- melalui metode immunofluorescence untuk memastikan bahwa sel

NEE 16  
UNIVERSITAS AIRLANGGA  
AYAH KUN

tersebut adalah sel MSCs dan juga melalui metode fluocytometri untuk memastikan sel yang diberiperlakukan  $O_2$  5% tidak mengalami perubahan setelah diobservasi pada pasase 9. Selanjutnya karakterisasi terhadap morfologi dari Colony Forming Unit-Fibroblast (CFU-Fs) dan sifat pluripotent stem cells dilakukan setelah dikultur kondisi low  $O_2$  5% dan dibandingkan dengan kultur konvensional normoksia  $O_2$  21%. Karakterisasi pluripotensi didasarkan pada dua marker spesifik, seperti SOX2 dan OCT4 melalui metode immunofluorescence.

Demikian halnya penelitian pada tahun ke-2 ini juga sudah terselesaikan 100% berupa observasi terhadap hambatan proses mutasi gen setelah dikultur pada kondisi low oksigen tension. Hambatan mutasi gen didasarkan pada ekspresi genotype genes OCT4, SOX2 dan CD44+. Ekspresi genotype genes OCT4, SOX2 dan CD44+ berturut turut berupa untaian cDNA sebesar 114 bp, 319 bp dan 551 bp. Kecocokan data didasarkan pada similarity significance value cut off  $\geq 60\%$  berdasarkan analisis penyejajaran dan kecocokan hasil sekuens gen pengkode sampel dengan whole genom yang ada di gene bank.

Rencana tahap berikutnya (pada tahun ke-3 dan ke-4) adalah observasi hasil transplantasi stem cells yang dikultur low oksigen tension dan dibandingkan dengan kultur konvensional pada hewan coba tikus, baik jantan dan betina.

## BAB 7. KESIMPULAN DAN SARAN

### Kesimpulan

Pluripotency stem cells yang disertai hambatan terhadap mutasi gen dapat dicapai melalui pemberian low oksigen tension 5% pada saat proses kultur in vitro

Pada tahun ke-1 : Pluripotency ditandai dengan dua marker spesifik, seperti SOX2 dan OCT4 melalui metode immunofluorescence yang sebelumnya telah diamati terhadap morfologi dari Colony Forming Unit-Fibroblast (CFU-Fs) yang khas serta undifferensiasi dari stem cells melalui pemeriksaan flowcytometri terhadap CD90+ dan CD44+ baik dengan CD45- maupun CD34-.

Pada tahun ke-2: Hambatan mutasi gen didasarkan pada ekspresi genotype genes OCT4, SOX2 dan CD44+. Ekspresi genotype genes OCT4, SOX2 dan CD44+ berturut turut berupa untaian cDNA sebesar 114 bp, 319 bp dan 551 bp. Kecocokan data didasarkan pada similarity significance value cut off  $\geq 60\%$  berdasarkan analisis penyejajaran dan kecocokan hasil sekuens gen pengkode sampel dengan whole genom yang ada di gene bank



UNIVERSITAS AIRLANGGA  
FACULTY OF SCIENCE  
DEPARTMENT OF CHEMISTRY  
Jember

## Saran

Perlu dilakukan penelitian lanjutan agar hasil transplantasi stem cells yang dikultur low oksigen tension dan dibandingkan dengan kultur konvensional pada hewan coba tikus, baik jantan dan betina yang mengalami infertilitas.

## DAFTAR PUSTAKA

- Barria E, A Mikels, and M Haas. 2004. Maintenance and Self-Renewal of Long-Term Reconstituting Hematopoietic Stem Cells Supported by Amniotic Fluid. *Stem Cells Dev.* Oct. 13(5):548-62.
- Gonzales E, MB Monasterio, G Tiscornia, NM Pulido, R Vassena, IB Morera, IR Piza, JCI Belmonte. 2009. Generation of Mouse-Induced Pluripotent Stem Cells by Transient Expression of a Single Non Viral Polycistronic Vector. *Proceedings National Academy of Science.* 106 (22):8918-8922.
- Halim DH, F Murty, A Sandra, T Boediono, B Djuwantono, dan B Setiawan. 2010. *Stem Cell Dasar Teori dan Aplikasi Klinis.* Penerbit Erlangga. Jakarta.
- He S, D Nakada, and SJ Morrison. 2009a. Mechanisms of Stem Cell Self-Renewal. *Annu Rev Cell Dev Biol.* 25: 377-406.
- He A, Y Jiang, and C Gui. 2009b. The Antiapoptotic Effect of Mesenchymal Stem Cell Transplantation on Ischemic Myocardium is Enhanced by Anoxic Preconditioning. *Can J Cardiol.* 29: 1888-97.
- Jawa Pos. 2013. Yamanaka Penerima Nobel Terapi dengan Pemanfaatan Stem Cells. Halaman 3. Tanggal 3 Pebruari 2013.
- Kolf CM, E Cho, RS Tuan. 2007. Review Mesenchymal Stromal. *Biology of Adult Mesenchymal Stem Cells : Regulation of Niche, Self-Renewal and Differentiation. Arthritis Research & Therapy.* 9:204 (doi:10.1186/ar2116). Available online <http://arthritis-research.com/content/9/1/204>.
- Okita K, M Nakagawa, H Hyenjong, T Ichisaka, S Yamanaka. 2008. Generation of Mouse Induced Pluripotent Stem Cells Without Viral Vectors. *Sciences.* 322(5903):949-953
- Rantam FA, Ferdiansyah, Nasronudin and Purwati. 2009. *Stem Cell Exploration. Methods of Isolation and Culture.* First Ed. Airlangga University Press. Surabaya
- Rizino A. 2009. Sox2 and OCT3/4: A Versatile Pair of Master Regulators that Orchestrate the Self Renewal and Pluripotency of Embryonic Stem Cells by Functioning as Molecular Rheostats. NIH –PA Author Manuscript. *Wiley Interdiscip Rev Syst Biol Med.* 2009; 1(2):228-236. Doi:10.1002/wsbm.12.
- Safitri. 2014. Prekondisi Hipoksia untuk Mencapai Long Term Maintenance (LTM) dari Quiescence BMSCs. Disertasi. Prodi Ilmu Kedokteran. Fakultas Kedokteran. Universitas Airlangga. Surabaya.
- Safitri<sup>a</sup> E, C. Utama, C. Bumi, SWM Mulyani, H. Susilowati, Purwati, RH. Prasetyo, M. Hariadi, FA. Rantam. 2013. Stem Cells Through an Adaptation in Low Oxygen Tension as an Attempt to Increase Cellular Transplantation Efficacy for Spermatogenesis Process. The 3rd Annual Conference Syah Kuala University. Unsyah, Banda Aceh, 2-4 Oktober 2013.
- Safitri<sup>b</sup> E, S. Utama, C. Bumi, SWM Mulyani, H. Susilowati, E. Retnowati, Purwati, RH. Prasetyo, M. Hariadi, FA. Rantam. 2013. The Role of Adaptive MSCs an Attempt Regeneration of Spermatogenesis Process Using by Hypoxia Precondition in Vitro. *J*



UNIVERSITAS AIRLANGGA  
PERPUSTAKAAN PATIEMAYEK  
P A S A R U S

- Anim Prod Adv 2013, 3(11); 318-322. ISSN: 2251-7677. Online version is available on: [www.grjournals.com](http://www.grjournals.com). And International Seminar The Role of Veterinary Science to Support Development Goals. JW Mariot Hotel Surabaya – Indonesia, September 5th – 6th, 2013
- Safitri<sup>a</sup> E, S. Utama, C. Bumi, RH. Prasetyo, Purwati and FA. Rantam. 2014. Quiescence Cells of Mesenchymal Stem Cells (MSCs) by Hypoxic Preconditioning for Therapeutic of Testis Degeneration Cause by Protein Energy Malnutrition. 6th ACTMP 2014. Global Challenges in Tropical Diseases: Bridging Gaps and Building Partnerships. 5-7 March 2014. Intercontinental Kuala Lumpur Malaysia.
- Safitri<sup>b</sup> E, S. Utama, C. Bumi, Aulani'am and FA. Rantam. 2014. Hypoxic Preconditioning for Viable and Self Renewing Mesenchymal Stem Cells (MSCs) as The Regeneration of Spermatogenesis Process. Accepted International Journal May 2014. Advances in Natural and Applied Sciences (18 ANAS May 2014). Scientific Journal Impact Factor (SJIF 2012 = 2,698).
- Song L, NE Webb, Y Song, RS Tuan. 2006. Identification and Functional Analysis of Candidate Genes Regulating Mesenchymal Stem Cell Self-Renewal and Multipotency. Stem Cells. 24: 1707-1718.
- Song H, BW Song, MJ Cha, IG Choi, KC Hwang. 2010. Expert Opinion. Modification of Mesenchymal Stem Cells for Cardiac Regeneration. Informa healthcare. DOI 10.1517/14712590903455997 @2010 informa UK Ltd. ISSN 1471-2598. All rights reserved: reproduction in whole or in part not permitted. 309-319.
- Sun N, NJ Panetta, DM Gupta, KD Wilson, A Lee, Fm Jia, S Hu, AM Cherry, RC Robins, MT Longaker, JC Wu. 2009. Feeder-free Derivation of Induced Pluripotent Stem Cells from Adult Human Adipose Stem Cells. Proceedings National Academy of Science. 106 (37):15720-15725.
- Szablowska-Gadomska I, V Zayat, L Buzanska. 2011. Influence of Low Oxygen Tension on Expression of Pluripotency Genes in Stem Cells. Acta Neuroiol Exp. 71: 86-93
- Tsai CC, YJ Chen, TL Yew, LL Chen, JY Wang, CH Chiu, and SC Hung. 2011. Hypoxia Inhibits Senescence and Maintains Mesenchymal Stem Cell Properties Through Downregulation of E2A-p21 by HIF-TWIST. [Bloodjournal.hematologylibrary.org](http://bloodjournal.hematologylibrary.org) by guest on July 18, 2012 @ 2012 by The American Society of Hematology. Blood, 13 January 2011. 117:2: 459-469. Nature. Doi:10.1038/nature07863.
- Woltjen K, IP Michael, P Mohseni, R Desai, M Mileikovsky, R Hailainen, R Cowling, W Wang, P Liu, M Grotstein, K Kaji, HK Sung, A Nagy, piggyback. 2009. Transposition Reprograms Fibroblasts to Induced Pluripotent Stem Cells
- Wang J, TL Chen, J Jiang, H Shi, C Gui, RH Luo, XJ Xie, MX Xiang, and X Zhang 2008. Hypoxic Preconditioning Attenuates Hypoxia/ Reoxygenation-Induced Apoptosis in Mesenchymal Stem Cells. Full-length Article. Acta Pharmacol Sin 2008 @2008 CPS and SIMM. Doi : 10.1111/j.1745-7254.2008.00716.x. Jan; 29(1): 74-82.
- Yamanaka S. 2007. Strategies and New Developments in the Generation of Patient-Specific Pluripotent Stem Cells. Cell Stem Cell Review. 1 July 2007 @2007 Elsevier Inc. DOI 10.1016/j.stem.2007.05.012.

Lampiran 1 Sertifikat Internasional Conference (Oral Presentation)



The Committee of  
The 2<sup>nd</sup> Veterinary Medicine International Conference 2018  
in Collaboration with ADPRC-OHCC

*Certify*

**Erma Safitri**

As Oral Presenter

In The International Conference  
"New Wave Bio-X Veterinary Medicine"  
"Strengthen on One Health, Biomedical, Reproduction,  
Nutrition and Clinical Science"

Surabaya, July 4<sup>th</sup> - 5<sup>th</sup> 2018

Dean  
Faculty of Veterinary Medicine  
Universitas Airlangga

Prof. Dr. Puji Sianto, M.Med., DVM



Chairman,

Prof. Dr. Fedik Abdul Rantam, DVM

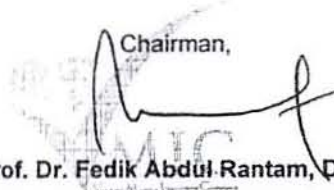

Recognized SKP:; Participant=75 ; Speaker, oral presenters/presentation posters=100





VI 1116  
KEMENTERIAN RISET  
TEKNOLOGI DAN  
TANPA BATAS  
AYAHAN

**Lampiran 2**

**Bukti Accepted Vet World & Proofread**



# VETERINARY WORLD

Open access and peer reviewed journal

Star, Gulshan Park, NH-8A, Chandrapur Road, Wankaner - 363621, Dist. Morbi (Gujarat) India,

Website: [www.veterinaryworld.org](http://www.veterinaryworld.org), Email: [editorveterinaryworld@gmail.com](mailto:editorveterinaryworld@gmail.com)

Editor-in-Chief: Anjum V. Sherasiya, Publisher: Veterinary World, EISSN: 2231-0916

NAAS (National Academy of Agricultural Sciences - India) 5.77

SCOPUS (Crossref) Q1, Q4, Q3, Q2, Q5

## By E-mail

Ref No. VW/Accept/159/2018

19-07-2018

To,  
R. Heru Prasetyo  
Department of Parasitology,  
Faculty of Medicine,  
Universitas Airlangga,  
Indonesia.  
E-mail: [rheru\\_prasetyo@yahoo.co.id](mailto:rheru_prasetyo@yahoo.co.id)

### Acceptance of article for publication in Veterinary World

Dear Dr.

I am pleased to inform you that your manuscript titled as -

**Quiescence cells, p63, which is regulated by hypoxia inducible factor 2, is crucial for spermatogonial stem cells (SSCs) function to improve testis failure and infertility** - Erma Safitri, Mas'ud Hariadi, Fedik Abdul Rantam and R. Heru Prasetyo

is accepted for publication in *Veterinary World*.

We have received the payment for publication (bill no. 97 dated 19-07-2018). So, you will receive the galley proof within 4-5 weeks. You must have to solve the query, if we point out any in galley proof.

After correction of galley proof, your article will be published online at [www.veterinaryworld.org](http://www.veterinaryworld.org) in chronological order.

Thanking You.

Yours Sincerely,

Dr. Anjum V. Sherasiya  
Editor-in-Chief  
Veterinary World



Indexed and Abstracted in Academic Journals Database, AGORA, AGRICOLA, AGRIS, CABI, CAS, DOAJ, EBSCO, ESCI-Thomson Reuters, Gale, Google Scholar, HINARI, Index Scholar, Indian Animal Science Abstracts, Indian Science Abstracts, JournalSeek, Open J-gate, ProQuest, PubMed, PubMed Central, SCOPUS, TEEAL

Dear Corresponding author/co-authors,

**PLEASE READ BELOW MESSAGE CAREFULLY BEFORE PROOF CORRECTION.**

- **Please collaborate with the corresponding author and send the correction to the corresponding author and he/she have to email corrected proof to us within 5 days. We will provide pdf proof after correction of copyedited proof. We will not allow the corrections in pdf proof (except our designer forget to do the corrections as per your suggestions). So, we suggest to be careful in corrections and read the proof repeatedly and do the corrections as per below suggestions. If there is no correction then reply accordingly**
- **The corresponding author has to put all co-authors in cc email when he/she send the reply to us.**
- **Please use Word 2010 (without compatibility mode i.e. save as Word document) to read and correct the proof with track changes and please save the file as Word document in Word 2010, please do not save in compatibility mode otherwise it may cause the spacing problem in the file. Another version of the Word may cause the spacing problem in the proof.**
- **Please do the changes in this word file with track changes only or reply in the comment box if any. Please do not add/delete anything without track changes. Also, send the corrections in a separate file with page no., line no. etc.**

- **WE USE US ENGLISH SO, PLEASE DO NOT CONVERT SPELLINGS TO UK ENGLISH (i.e. estrus to oestrus, hematological to haematological etc.). However, convert words of UK English to US English if we forget to convert**
- **WE HAVE COPYEDITED AT MANY SENTENCES. We have not provided the article with track changed corrections as many authors get confused. SO, PLEASE CHECK EACH SENTENCE CAREFULLY.**
- **Please refer latest articles from [www.veterinaryworld.org](http://www.veterinaryworld.org) for a format of the manuscript i.e. Authors name, affiliation, emails, text part, Authors' contribution, Acknowledgement, references etc.**
- **Introduction must be divided into 3 paragraphs i.e. 1. introduction 2. significance of the study and 3. aim of the study.**
- **Ethical approval must be included as per the format of Veterinary World in Materials and Methods section.**
- **Check the highlighted words if any in your manuscript.**
- **Please do not delete <H1>, <H2> etc from the manuscript as these are heading suggestion for the designer.**
- **Check whole manuscript carefully for any mistake in author name (first name, second**

ame (optional) and last name), affiliation, emails, how to cite (reverse sequence of author  
ame), text of article, abbreviation, full forms, figures (if any - figures will be formatted in  
xact size in the PDF), tables (if any). etc. Please check that all figures/tables are cited in the  
ext part or not? Correct the manuscript as per comments given in right column if any. Please  
e careful in correction as we will create the PDF directly from this file. We will provide the  
PDF as final proof before publication.

PLEASE CHECK THAT ALL REFERENCES ARE IN CONTINUOUS NO. OR NOT  
and also as per the format of Veterinary World or not? If you amend any reference no. in the  
text then arrange the remaining reference no. in continuous no. in the text as well as in  
reference section.

Please include authors' contribution section, acknowledgment along with the source of  
the fund for the study, competing interests statement etc if you have not included. Source of  
the fund is necessary for a research article. Include grant/project/fund etc no. in  
Acknowledgement section if you have not included.

Technical/Copyediting by Sinjore – 21/08/2018

## RESEARCH ARTICLE

~~Quiescence cells, p63, which is regulated by hypoxia-inducible factor 2 $\alpha$ , is crucial for  
spermatogonial stem cell function to improve testis failure and infertility~~ (1, 2)

Erma Safitri<sup>1,2</sup>, Mas'ud Hariadi<sup>1</sup>, Fedik Abdul Rantam<sup>2,3</sup> and R. Heru Prasetyo<sup>4</sup>

1. Department of Veterinary Reproduction, Faculty of Veterinary Medicine, Universitas Airlangga, Indonesia; 2. Division of Stem Cells Research, Institute Tropical Disease (ITD), Universitas Airlangga, Indonesia; 3. Department of Microbiology, Faculty of Veterinary Medicine, Universitas Airlangga, Indonesia; 4. Department of Parasitology, Faculty of Veterinary Medicine, Universitas Airlangga, Indonesia.

**Corresponding author:** R. Heru Prasetyo, RHP: rheru\_prasetyo@yahoo.co.id

**Co-authors:** ES: rma\_fispro@yahoo.com/erma-s@fkh.unair.ac.id, MH: masudhariadi@yahoo.co.id,

FAR: fedik.ar@gmail.com

**Received:** 16-03-2018, **Accepted:** 19-07-2018, **Published online:** \*\*\*

**doi:** \*\*\* **How to cite this article:** Safitri E, Hariadi M, Rantam FA, Prasetyo RH (2018)

~~Quiescence cells, p63, which is regulated by hypoxia inducible factor 2 $\alpha$ , is crucial for spermatogonial stem cell function to improve testis failure and infertility~~, *Veterinary World*, 11(8):0-0.

## **Abstract**

**Aim:** The aim of this research was to examine the quiescence cells, p63, which is regulated by hypoxia-inducible factor 2 $\alpha$  (HIF2 $\alpha$ ) is crucial for spermatogonial stem cell (SSC)

unction to improve testis failure and infertility.

**Materials and Methods:** Stem cells were transplanted into male rat which testicular failure has been induced infertile, compared with negative and positive control. In the first treatment (T1) group, 10 male infertile rats were transplanted with stem cells from normoxia culture (O<sub>2</sub> 21% concentration) for 4 days with a dose of 200 million cells/rat; in the second treatment (T2) group: 10 male infertile rats were transplanted with stem cells from hypoxia culture (O<sub>2</sub> 1% concentration) for 4 days with a dose of 200 million cells/rat; in the negative control (T0-) group, 10 normal male rats (fertile rat) were injected with 0.1 cc phosphate buffer saline (PBS); and in the positive control (T0+) group, 10 male infertile rats were injected with 0.1 cc PBS.

**Results :** The stem cells from hypoxia precondition culture (O<sub>2</sub> 1% concentration) for 4 days with a dose of 200 million cells/rat (T2 group) were transplanted, is effective as a treatment for testis failure and infertile male of rat based on the quiescence cells (p63) and SSCs expression, which is regulated by HIF2 $\alpha$ . Furthermore, the tubulus seminiferous tubule of testis also occurs improvement, including Sertoli, Leydig, spermatogonium, spermatocyte primary-secondary, and spermatid cells.

**Conclusion:** The quiescence cells, p63, which is regulated by HIF2 $\alpha$  from hypoxic precondition culture with 1% O<sub>2</sub> concentration for 4 days with a dose of 200 million cells/rat is crucial for SSC function and effectively as a treatment for testis failure and infertility in



male rats.

**Keywords:** hypoxia, infertility, p63, quiescence cells, spermatogonial stem cells.

## **H1>Introduction**

Stem cell transplantation renders promising results for testicular tissue regeneration of male infertility with testis failure [1,2]. However, ~~the treatment has limited efficacy due to low of stem cells viability was transplanted [3-5]~~ [3-5]. The low viability of the stem cells is allegedly due to the normoxia culture with high oxygen tension ( $O_2 \geq 20\%$ ). The normoxia culture can cause the cell senescence [6], cell apoptosis [7], and mutation of gene [8]. Furthermore, after transplantation, this cell transplantation therapy is limited by its poor viability. Apoptosis is thought to be the major factor that affects the efficiency of mesenchymal stem cell transplantation [9-14]. Therefore, high doses are required to achieve therapeutic effectiveness. It takes effort to create compliance with the dosage through several times of transplantation (booster [10,11]), so it will cost very much for stem cell transplant program, although the effectiveness of therapy remains in doubt.

Stem cells were cultured in hypoxia precondition ( $O_2$  1-3%) and maintain viable and adaptive conditions when transplanted [2]. This condition was caused by long-term maintenance [15,16] and called as quiescence stem cells [17-19]. The quiescence cells, p63, which is allegedly regulated by hypoxia-inducible factor  $2\alpha$  (HIF $2\alpha$ ), is crucial for the function of progenitor stem cells. The quiescence cells occur when the stem cells reside in Gap zero (G0)

and do not go into the cycling state (Gap1/Sintesis/Gap2/Mitosis) [20] and undifferentiated state [21] but are still in the proliferation [22].

In the testicular tissue, hypoxic conditions (1-3% O<sub>2</sub> concentration) are crucial for spermatogonial stem cell (SSC) function through spermatogenesis process [23]. The aim of this research was to examine the quiescence cells, p63, which is regulated by HIF2 $\alpha$ , is crucial for SSC function to improve testis failure and infertility.

## **<H1>Materials and Methods**

### **<H2>Ethical approval**

All the experiments including animal works were approved by Ethical Committee vide Ethical Clearance KE (Komisi Etik Penelitian), No: 239-KE, Animal Care and Use Committee (ACUC), Veterinary Medicine Faculty, Universitas Airlangga, Surabaya, Indonesia, and were performed based on the committee guideline.

### **<H2>Procedure of stem cell isolation**

Stem cells were harvested from bone marrow by aspiration at the middle femur below the condylus of the rabbit (New Zealand strain). The aspirate was put in heparinized tubes and stored and maintained at 4°C for transportation to the laboratorium [24].

### **<H2>Procedure of stem cell culture**

The aspirate from bone marrow was transferred into sterile 15 ml tubes, then rinsed twice with sterile phosphate buffer saline (PBS) 5 ml, and filled up to a total volume of 10 ml. The diluted sample was loaded over the same volume of Ficoll (Biowest) in a separate 15 ml tube. Centrifugation was performed for 15 min at room temperature at 1600 rpm. After centrifugation, the cells were collected from Ficoll-PBS interface using Sterile Pasteur Pipette and transferred into a 15-ml tube. The cells were resuspended in PBS up to a total volume of 15 ml. The tube was inverted gently 5 times to homogenize the suspension.

The suspension was centrifuged again for 10 min, supernatant and floating cells were discarded, and cell pellet was resuspended in 6 ml of alpha-modified essential medium ( $\alpha$  MEM) (Sigma E121P13). Mononucleated cells were plated in 10 cm<sup>2</sup> with approximately  $2 \times 10^7$  cell number and incubated at 37 °C in a humidified atmosphere containing 5% CO<sub>2</sub> for 24 h to let the cells adhere. After 24 h, media and non-adherent cells were discarded. Adherent cells were rinsed twice using 5 ml of PBS. About 10 ml of fresh  $\alpha$ -MEM media was then added into the dish, and the dish was returned into the incubator. Culture was observed daily under an inverted microscope. Every 4 days, medium was changed and preceded by a rinse using 10-ml PBS, after which 10 ml of fresh  $\alpha$ -MEM media was added. Culture was continued until approximately 75-80% confluence was attained. After confluence, cells were passaged into several dishes for subculture [24]. Passage was conducted 3 times, and then, cells were divided into two hypoxia precondition treatments of 1% in hypoxia chamber inside a 5% CO<sub>2</sub> incubator, while another treatment was the use of 21% oxygen concentration

normoxia) during 4 days.

## <H2>Infertile rat model

Rat model with testicular failure in this research was using male rats which are available through food fasting 5 days long, but drinking water is still administered [25,26]. ~~The animals model was used in this study are male rats (*Rattus norvegicus*), Wistar strain and 250-300 g body weight each, 8-10 week old and healthy condition [15].~~ The rats were placed in a plastic cage individually in animal laboratory experimental at the Faculty of Veterinary Medicine, Universitas Airlangga.

## <H2>Stem cell transplantation methods

~~Stem cells were transplanted into male rat which testicular failure has been induced infertile, compared with negative and positive control [16] [17].~~ In the first treatment (T1) group, 10 male infertile rats were transplanted with stem cells from normoxia culture (O<sub>2</sub> 21% concentration) for 4 days with a dose of 200 million cells/rat; in the second treatment (T2) group, 10 male infertile rats were transplanted with stem cells from hypoxia culture (O<sub>2</sub> 1% concentration) for 4 days with a dose of 200 million cells/rat; in the negative control (T0-) group, 10 normal male rats (fertile rat) were injected with 0.1 cc PBS; and in the positive control (T0+) group, 10 male infertile rats were injected with 0.1 cc PBS.

~~After 35 days, male rats were excised to collect testicle tissue [18] [19].~~ The testicular tissue

improvement was observed by histopathological preparations with hematoxylin eosin (HE) stain. Immunohistochemical (IHC) observation was performed to determine the expression of p63 as quiescence cell marker (L20)(P21), HIF2- $\alpha$  as crucial factor for SSCs, and SSCs as progenitor function to improve testis failure and infertility. Fertility observation from male rats was performed through *in vitro* fertilization between ovum and sperm.

## <H2>Testicular tissue improvement

Testicular tissue improvement was identified by spermatogonia, Sertoli, Leydig cells, and seminiferous tubule of the testes through histopathological examination (L22)(P23). Rats' testicular fixation in 10% formalin (P24) and one hour later, in mid-testis was injected with formalin 10% (L25). After that, rats' testes dehydrated in alcohol solution with a higher concentration gradually, i.e., from 70%, 80%, 90%, and 96%. Then, the testes of rats were cleared with xylol solution. Furthermore, embedding was done using paraffin liquid and rats' testes were put into molds containing paraffin liquid. Before staining and sectioning, an incision using a microtome was made and mounted on glass objects (L26). Furthermore, the staining was done by removing paraffin with xylol, then put into a solution of alcohol with decreased concentration, from 96%, 90%, 80%, and 70%, and then put it into HE staining procedure. The last stage after staining was mounting and put into alcohol to remove excess stain. Then, it was put into a solution of alcohol with increasing concentration, from 70%, 80%, 90%, and 96%, and then put into xylol. Preparations were then covered with a cover

The media M16 and PBS are manufactured in accordance with the procedure of making the two mediums. Before the use for *in vitro* fertilization, a droplet medium was prepared in a Petri dish with a volume of 50  $\mu\text{L}$  as a washing medium and 25  $\mu\text{L}$  as an *in vitro* culture medium. The droplet medium was then incubated for 3 h in a 5%  $\text{CO}_2$  incubator at 37°C before being used for *in vitro* fertilization [30].

In male rats, sperm collection was taken after the rats were killed by cervical dislocation of the fourth cervical spine and disinfected with 70% alcohol. Make an incision that resembles the letter Y in the abdomen, the stomach contents are removed, and the left testicle is pulled. The fats are separated, and then, the part of the cauda epididymis which is the mature sperm shelter is taken. The obtained cauda epididymis was washed with PBS 2 times and cut into small pieces to free the spermatozoa, then placed on M16, and incubated in an incubator with 5%  $\text{CO}_2$  at 37°C [31].

Before oocyte collection, hormone of pregnant mares' serum gonadotropin (PMSG) and human chorionic gonadotropin (hCG) was injected intra subcutaneously to stimulate superovulation with sequence as follows: On the 1<sup>st</sup> day of the 0<sup>th</sup> h, female rats injected PMSG 5 IU 0.1 cc to stimulate the process of folliculogenesis and left for 48 h. After 48 h PMSG injection, female rats were injected with 5 IU of 0.1 cc hCG and mated single directly with a vasectomy male to snapping ovulation. [17 h later vaginal plug examination to find out positive females mating and done flushing of oocyte] [31] [32]. The female rats were killed by cervical dislocation of the fourth cervical spine, and then, the Y incision was made on the

abdomen, taken by the uterus, and separated from the fallopian tube section, after which the M16 medium was rinsed. ~~Flushing of the oocyte on the ampoule of the fallopian tube under an inverted microscope [14,33] [34] [29].~~

### <H3>*In vitro* fertilization

The ovum and sperm were incubated using modified Pasteur pipettes transferred to Petri dishes containing M16 drops fixed with mineral oil and incubated in 5% CO<sub>2</sub> incubators at 37°C for 5 h for *in vitro* fertilization [31].

### <H2>Statistical analysis

The expression of p63, HIF2 $\alpha$ , and SSCs and fertility rate of sperm were statistically analyzed using SPSS 17 for Windows XP with the confidence level 99% ( $\alpha=0.01$ ) and the level of significance 0.05 ( $p=0.05$ ). The steps comparative of hypothesis testing are as follows: The normality data test with the Kolmogorov–Smirnov test, homogeneity of variance test, analysis of variance (ANOVA), and *post hoc* test using the Tukey HSD 5% as the least significant difference test.

### <H1>Results

Data were collected from 40 male rats which were divided into four treatment: Negative control (T0-) group is normal male rat (fertile rat); positive control (T0+) group is male infertile rat without stem cells transplantation; the first treatment (T1) group is male infertile

rats which were transplanted with stem cells from normoxia culture (O<sub>2</sub> 21% concentration) for 4 days, and the second treatment (T2) group is infertile male rats which were transplanted with stem cells from hypoxia culture (O<sub>2</sub> 1% concentration) for 4 days. In detail, the results of the study are as follows: ~~The effectiveness of stem cell therapy from hypoxia precondition culture to improve testis failure and infertility was based on the following:~~ (1) Expression of p63, (2) expression of HIF2 $\alpha$ , (3) expression of SSCs, (4) regeneration of testicular tissue (such as intact of tubulus seminiferous tissue, formation of Sertoli cells, Leydig cells, spermatogonium, spermatocyte primary-secondary, and spermatid cells), and (5) improvement of fertility rate of sperm *in vitro*.

## <H2>The expression of p63

The mean expression of p63 in T2 group is  $27.143^b \pm 1.433$  (<30%), although the percentage is lower than negative control (T0-) group with value of  $51.429^a \pm 1.711$  (>50%), but the percentage is still well higher than T1 group with value of  $4.286^c \pm 0.632$  (<5%) and the positive control (T0+) group was not expressed at all  $0^d \pm 0$  (0%) (Figure-1 and Table-1).

## <H2>The expression of HIF2- $\alpha$

The mean expression of HIF2- $\alpha$  in T2 group is  $31.15^a \pm 1.35$ , this mean is highest compared to the other, respectively, T1, T0-, and T0+ =  $14.25^b \pm 0.5$ ,  $0^c \pm 0$ , and  $0^c \pm 0$  (Figure-2 and Table-1). ~~The increase of HIF2 $\alpha$  expression, along with a decrease of the oxygen concentration~~



~~rovided, the lower of oxygen concentration is given, the higher of HIF-2 $\alpha$  expression. (p=0.1138)~~

## <H2>The expression of SSCs

The mean expression of SSCs in T2 group is  $65.714^b \pm 1.817$  (<70%), although the percentage is lower negative control (T0-) group with the value of  $88.571^a \pm 1.947$  (>80%), but the percentage is still well higher than T1 group with value of  $7.143^c \pm 0.854$  (<10%) and the positive control (T0+) group was not expressed at all  $0^d \pm 0$  (0%) (Figure-3 and Table-1).

## <H2>Regeneration of testicular tissue

The microscopic examination showed that the T2 group leads to the occurrence of testicular tissue repair. Improvements are identified based on the regeneration of Sertoli cells, Leydig cells, spermatogonium, spermatocyte primary-secondary, and spermatid cells and seminiferous tubules regenerate intact. Overview of these improvements can be compared with a negative control (T0-) group who did not experience testicular degeneration, which remains in normal condition (Figure-4d, 4a and Table-2). The T1 group does not indicate the occurrence of testicular tissue repair. ~~Not the improvement in the form of cell degeneration spermatogonia, Sertoli cells and Leydig cells and seminiferous tubules that are no longer intact. (p=0.1138)~~ Figure of the damage can be compared with positive control (T0+) group with testicular degeneration (Figure-4b, 4c and Table-2).

## <H2>Improvement of fertility rate of sperm

Sperm fertility of male rat was obtained by taking sperm from cauda epididymis. The sperm is placed in the falcon cup containing the female rat ovum that has been injected PMSG and hCG and incubated for 5 h in a 5% CO<sub>2</sub> incubator at 37°C. The fertility rate is calculated based on many zygote obtained divided by number of ovum and multiplied by 100%. The fertility rate of male rat sperm after analyzed one-way ANOVA, got the mean of fertility rate of sperm male rat standard deviation can be seen as Table 3 (L.41 | P.42).

## <H1>Discussion

The study showed that stem cells from hypoxia precondition culture are effectiveness for the therapy of male rat with testis failure and infertility was based on expression of p63, HIF2 $\alpha$ , and SSCs by IHC, regeneration of testicular tissue by HE staining, and improvement of fertility rate of sperm *in vitro*.

The identification of protein p63 as a marker of quiescence cells was done through IHC methods. The differentiation of stem cells to regeneration based on decreased of p63 as compared with the negative control (T0-) group (L.43 | P.44). This research has demonstrated that T2 group is lower (<30%) than negative control (T0-) group (>50%), but the percentage is still well higher than T1 group with value of <5% and the positive control (T0+) group which was not expressed at all 0% (Figure-1 and Table-1).

The p63 gene is a transcription factor family and has a close relationship with the tumor suppressor protein p53. ~~The p63 gene has an ability to sustain availability to regenerate epithelial stem cells and variety of cells from other tissues, is known as the ringmaster [LE43] [P46].~~ In the previous studies, the absence of p63 showed a decreased ability to proliferate, and p63 is a key function to increase the division of stem cells. [This is because p63 genes more directly genes stemness promotes and controlling the stem cell niche and undifferentiation process.] [P47] [LE48] The p63 is a key regulator of stem cells that maintain a fixed maintenance as quiescence and inhibits the differentiation [19].

The mean identification of HIF2- $\alpha$  in T2 group is highest compared to other. ~~The increase of HIF2 $\alpha$  expression, along with a decrease of the oxygen concentration provided, the lower of oxygen concentration is given, the higher of HIF2 $\alpha$  expression [LE49] [P50].~~ *In vitro* cultures, low oxygen tension (hypoxia), and cultivation time administration of oxygen induce pluripotency gene expression [32], such as OCT4, SOX2 [2,33], c-Myc [33], and Nanog [34]. Pluripotency genes are activated by HIF-2 $\alpha$  [35] after preceding initial adaptation time by HIF-1 $\alpha$  [8]. Pluripotency of these stem cells can retain quiescence cells, so the function of stem cells is maintained. The quiescence cells with p63 as marker, which is regulated by HIF2 $\alpha$  from hypoxic precondition culture with 1% O<sub>2</sub> concentration for 4 days, is crucial for the process of spermatogenesis in seminiferous tubule of testis.

Furthermore, stem cells from hypoxia precondition culture were found to be effective based

on SSC formation as a result of the differentiation of the transplanted stem cells. [151][152] The SSCs are progenitors of germline stem cells which are formed by the differentiation of stem cells. In this study, identification of SSCs can be done through IHC methods. The expression of SSCs in the T2 group is approximately 70%. Although the percentage is below the negative control (T0-) group which is greater than 80%, the percentage is still well above the T1 group with value <10% and a positive control (T+) group which is not expressed at all (0%) (Figure-3 and Table-1). The previous research showed that stem cell derived bone marrow is adult stem cells that will quickly grow and differentiate into cells that are needed in response to the presence of defect [36].

The regeneration of testicular tissue is the fourth identification of the viability of the transplanted stem cells, such as intact of tubulus seminiferous tissue, formation of Sertoli cells, Leydig cells, spermatogonium, spermatocyte primary-secondary, and spermatid cells.

The viability stem cells that differentiate into cells will be needed. ~~In infertile conditions, which are degenerative testicular tissue will regenerate if the stem cells are viable.~~ [153][154].

However, otherwise if it was not viable, then it will remain degeneration of testicular tissue.

The stem cell survival in animal model of degenerative tissue like testis failure is one factor among the factors which hurdle the therapeutic effect of stem cells treatment. The poor survival after cell transplantation is a crucial one [3]. This study showed that stem cells from hypoxia precondition culture are survival. It is based on the effectiveness for the therapy of male rat with testis failure and infertility through the regeneration of testis. The regeneration

of the testes can be observed through the method of histopathology anatomy with HE staining and then examined with light microscope [27]. The testicular tissue repair is identified based on the regeneration of seminiferous tubule cell which intact [LESS]P56][26].

In this study, the microscopic examination showed that T2 group leads to the occurrence of testicular tissue repair. The overview of the testicular tissue repair can be compared with the negative control (T0-) group who did not experience testicular degeneration, which remains in normal condition (Figure-4 and Table-2). ~~As for the T1 group does not indicate the occurrence of testicular tissue repair [LESS]P58].~~ Figure of the tissue damage can be compared with positive control (T0+) group with testicular degeneration (Figure-4 and Table-2).

## <H1>Conclusion

The quiescence cells, p63, which is regulated by HIF2 $\alpha$  from hypoxic precondition culture with 1% O<sub>2</sub> concentration for 4 days with a dose of 200 million cells/rat is crucial for SSCs function and effectively as a treatment for testis failure and infertile male of rat.

## <H1>Authors' Contributions

All the authors conceptualized the manuscript. ES and RHP drafted the manuscript preparation. ES: Research project leader, research and ethical clearance preparation, observation of IHC method, observation of fertility of the sperm *in vitro*, and coordinating research. MH: Stem cells isolation from rabbit bone marrow and observation of HE staining.

**FAR: Stem cells culture normoxia and hypoxia, stem cells transplantation. RHP: Rat infertile model, designed the study, and analyzed statistical data, and corresponding author. All the authors have read and approved the final version of the manuscript.**

## **<H1>Acknowledgments**

The study was supported by funding from the Directorate General of Higher Education (DIKTI) 2017, The National Education Ministry, Republic of Indonesia.

## **<H1>Competing Interests**

The authors declare that they have no competing interests.

## **<H1>References**

1. Cakici, C., Buyrukcu, B., Duruksu, G., Haliloglu, A.H., Aksoy, A., Isjk, A., Uludag, O., Ustun, H., Subas, C. and Karaoz, E. (2013) Recovery of fertility in azoospermia rats after injection of adipose-tissue-derived mesenchymal stem cells: Tha sperm generation. *Bio. Med. Res. Inter.*, 10: 1-18.
2. Safitri, E., Utama, S., Bumi, C., Mulyani, S.W.M., Retnowati, E., Purwati, P.R.H., Hariadi, M., Aulani'am, M.F. and Rantam, F.A. (2014) Hypoxic preconditioning for viable and self renewing mesenchymal stem cells (MSCs) as the regeneration of spermatogenesis process. *Adv. Nat. Appl. Sci.*, 8(8): 42-46.
3. Li, L., Chen, X., Wang, W.E. and Zeng, C. (2016) Review article: How to

improve the survival of transplanted mesenchymal stem cell in ischemic heart? *Stem Cells Inter.*, 10: 1-14.

4. ~~???~~[Anbu63][P64]

5. Safitri, E., Utama, S., Bumi, C., Mulyani, S.W.M., Susilowati, H., Retnowati, E., Purwati, P.R.H., Hariadi, M. and Rantam, F.A. (2013) The role of adaptive MSCs an attempt regeneration of spermatogenesis process using by hypoxia precondition *in vitro*. *J. Anim. Prod. Adv.*, 3(11): 318-322.

6. Tsai, C.C., Chen, Y.J., Yew, T.L., Chen, L.L., Wang, J.Y., Chiu, C.H. and Hung, S.C. (2011) Hypoxia inhibits senescence and maintains mesenchymal stem cell properties though down-regulation of E2A-p21 by HIF-TWIST. *Blood J. Hematol.*, 117(2): 459-469.

7. Mulyani, S.W.M., Setiawati, E.M., Safitri, E. and Astuti, E.R. (2014) The role of heat shock protein 27(HSP 27) as inhibitor apoptosis in hypoxic conditions of bone marrow stem cell culture. *Dent. J. (Maj. Ked. Gigi)*, 47(1): 41-44.

8. Szablowska-Gadomska, I., Zayat, V. and Buzanska, L. (2011) Influence of low oxygen tension on expression of pluripotency genes en stem cells. *Acta Neuroiol. Exp.*, 71: 86-93.

9. ~~Foma, C., Pittenger, M.F. and Cahill, K.S. (2002) Human mesenchymal stem cells differentiate to a cardiomyocyte phenotype in the adult murine heart. *Circulation*, 105: 93-98.~~ Cai, B., Li, X., Wang, L.Y., Yang, F., Chen, H., Yin, K., Tan, X., Zhu, J.,

*Adv Hemato Stem Cell Res.*, 2011, 133-146.

16. Yue, F., Bil, P., Wang, C., Shan, T., Nie, Y., Ratliff, T.L., Timothy, P. Gavin, T.P. and Kuang, S.(2017) Pten is necessary for the quiescence and maintenance of adult muscle stem cells. *Nature Comm.*, 10: 1-13.

~~Eliason, P., Rehn, M., Hammar, P.,~~

~~Larsson, P., Sirenko, O., Flippin, L.A., Cammenga, J. and Johnson, J.I. (2010)~~

~~Hypoxia mediates low cell cycle activity and increases the proportion of long-term~~

~~reconstituting hematopoietic stem cells during *in vitro* culture. *Exp Hematol.*, 38: 301-~~

~~310.[S71]~~

17. Nakamura-Ishizu, A., Takizawa, H. and Suda, T. (2014) Reviews: The analysis, roles and regulation of quiescence in hematopoietic stem cells. *Development*,

141: 4656-4666. Mohyeldin, A., Muvidi, T.G. and Hiojosa, A.Q. (2010) Cell stem cell

review- oxygen in stem cell biology: A ceitical component of the stem cell niche. *Cell*

*Stem Cell*, 7: 150-161.[S72]

18. Suda, T., Takubo, K. and Semenza, G.L. (2011) Cell stem cell review.

Metabolic regulation of ematopoietic stem cells in hypoxic niche. *Cell Stem Cell*, 9:

296-310.

19. Safitri, E., Utama, S., Prasetyo, R.H., Hariadi, M., Rantam, F.A. (2014)

Quiescence stem cells (QSCs) for the treatment of infertility in male mice. *Asian*

*Acad. Res. J. Multidisc.*, 1(28): 187-199.

20. [??][Anbu73][P74]



21. Rumman, M., Dhawan, J. and Kassem, M. (2015) Concise review: Quiescence in adult stem cells: biological significance and relevance to tissue regeneration. *Stem Cells*, 33: 2903-12. Lanneau, D., de Thonel, A., Maurel, S., Didelot, C. and Garrido, C. (2007) Apoptosis versus cell differentiation role of heat shock proteins HSP 90, HSP70 and HSP27. *Prion*, 1(1): 53-60.[S75]
22. Daignan-Fornier, B. and Sagot, I. (2011) Proliferation/quiescence: When to start? Where to stop? What to stock? *Cell Division*, 6(20): 1-5. Arai, F. and Suda T. (2008) Quiescent stem cells in the niche. *Stembook.ed. The Stem Cell Research Community. StemBook. Available from: <http://www.stembook.org>*[S76][S77]
23. Helsel, A.R., Oatley, M.J. and Oatley, J.M. (2017) Glycolysis-optimized conditions enhance maintenance of regenerative integrity in mouse spermatogonial stem cells during long-term culture. *Stem Cells Rep.*, 8(9): 1430-1441. Wenger, R.H. and D.M. Katschinski. (2005) The hypoxic testis and post-meiotic expression of pas domain proteins a review. *Cell Develop. Biol.*, 3(8): 547-553.[S78]
24. Eleotério, R.B., Sepúlveda, R.V., Reis, E.C.C., Valente, F.L. and Borges, A.P.B. (2016) Isolation, expansion and differentiation of mesenchymal stromal cells from rabbits' bone marrow. *Pesq. Vet. Bras.*, 36(5):423-430. Rantam, F.A., Ferdiansyah, N. and Purwati, T. (2009) Stem cell exploration. Methods of isolation and culture. 1<sup>st</sup> edition. Surabaya, Indonesia: Airlangga University Press. p53-65.[S79]

25. Prasetyo, R.H. (2015) Infeksi Parasit usus Oportunistik. 1<sup>st</sup> ed. Surabaya, Indonesia: Airlangga University Press. p7. ~~Prasetyo, R.H. (2010) Perubahan ekspresi CD4, IgA, PGE2 dan Hsp70 mukosa usus Mus musculus Balb C kurang energy protein yang diinfeksi cryptosporidium. 1<sup>st</sup> ed. Surabaya, Indonesia: Airlangga University Press. p1-10. [S80]~~
26. Safitri, E., Utama, S., Widiyatno, T.V., Sandhika, W and Prasetyo, R.H. (2016) Auto-regeneration of mice testicle seminiferous tubules due to malnutrition based on stem cells mobilization using honey. *Asian Pac. J. Reprod.*, 5(1): 31-35.
27. Razi, M., Najafi, G., Feyzi, S., Karimi, A., Shahmohamad, S. and Nejati V. (2012) Histological and histochemical effects of Gly-phosate on testicular tissue and function. *Iran J. Reprod. Med.*, 10(3): 181-192. ~~Eekmann, L. (2007) Animal models of inflammatory bowel disease, lesson from enteric infections. *Ann NY Acad. Sci.*, 1072: 28-38. [S81]~~
28. Safitri, E., Widiyatno, T.V. and Prasetyo, R.H. (2016) Honeybee product therapeutic as stem cells homing for ovary failure. *Vet. World*, 9(11): 1324-1330.
29. Widjiati, P.S.E. and Arifin, MZ. (2012) Perbandingan angka fertilitas dan hambatan perkembangan embrio mecit yang dikultur dalam medium M16 dan Human Tubal Fluid. *J. Vet.*, 13(3): 227-234.
30. Widjiati, R.A., Sosiawati, S.M. and dan Lukiswanto, B.S. (2012) Identifikasi protein epidermal growth fator (EGF) 46 kDa hasil maturasi oosit sapi secra *in vitro*.

*J. Kedokteran Hewan*, 6(1): 32-35.

31. Nabavi, N., Todehdeghan, F. and Shiravi, A. (2013) Effect of caffeine on motility and vitality of sperm and *in vitro* fertilization of outbreed mouse in T6 and M16 media. *Iran J. Reprod. Med.*, 11(9): 741-746. ~~Widjiati, R.A.W. and dan Arifin, M.Z. (2008) Pengaruh berbagai konsentrasi krioprotektan propanadiol pada proses vitrifikasi terhadap viavilitas embrio moneit pasca thawing. *Veterinaria*, 4(2): 17-23. [P83]~~
32. ~~Youssef, A. and Han, V.K.M. (2016) Low oxygen tension modulates the insulin-like growth factor-1 or -2 signaling via both insulin-like growth factor-1 receptor and insulin receptor to maintain stem cell identity in placental mesenchymal stem cells. *Endocrinology*, 157: 1163-1174. Grskovic, M. and Santos, M.R. (2008) The pluripotent Transcriptome. The Stem Cell Research Community. Available from <http://www.stembook.org>. [S83]. Lavagnoli, T., Gupta, P., Hermanseder, E., Mira-Bontenbal, H., Dharmalingam, G., Carroll, T., Gurdon, J.B., Fisher, A.G. and Merckenschlager, M. (2014) Initiation and maintenance of pluripotency gene expression in the absence of cohesion. *Genes. Develop.*, 29: 23-38. Yamanaka, S. (2007) Strategies and new developments in the generation of patient-specific pluripotent stem cells. *Cell Stem Cell Review*. 12: 79-87. [S84]~~
33. ~~???~~ [Anbu85] [P86]
34. Festuccia, N., Osomo, R., Wilson, V. and Chambers I. (2013) The role of

pluripotency gene regulatory network components in mediating transitions between pluripotent cell states. *Curr. Op. Genetics Develop.*, 23(5): 504-511. Kelf, C.M., Cho,

E. and Tuan, R.S. (2007) Review mesenchymal stromal. Biology of adult mesenchymal stem cells: Regulation of niche, self-renewal and differentiation. *Arthritis Res. Ther.*, 9: 204.[S87]

35. Dengler, V.L., Galbraith, M. and Espinosa, J.M. (2014) Transcriptional regulation by hypoxia inducible factors. *Crit. Rev Biochem Mol. Biol.*, 49(1):1-15.

Forristal, C.E., Wright, K.L., Hanley, N.A., Oreffo, O. and Houghton, F.D. (2010) Hypoxia inducible factor regulate pluripotency and proliferation in human embryonic stem cells cultured at reduced oxygen tensions. *Reprod.*, 139: 85-97.[S88]

36. Li, L. and Bhatia, R. (2011) Stem cell quiescence. Clin cancer res published online. *Clin Cancer Res.*, 17(15): 57-69.

## Tables

**Table-1:** The mean expression of p63, HIF2 $\alpha$ , and SSCs in some treatments by immunohistochemical method.

Treatments	p63	HIF2- $\alpha$	SSCs
Negative control (T0-) group: Normal male rat (fertile rat) was injected with 0.1 cc PBS	51.429 <sup>a</sup> ±1.711	2.858 <sup>c</sup> ±0.5	88.571 <sup>a</sup> ±1.947

Positive control (T0+) group: Male infertile rats were injected with 0.1 cc PBS	1.429 <sup>d</sup> ±0.4	2.858 <sup>c</sup> ±0.5	1.429 <sup>d</sup> ±0.4
First treatment (T1) group: Male infertile rats were transplanted with stem cells from normoxia culture (O <sub>2</sub> 21% concentration) for 4 days with a dose of 200 million cells/rat	4.286 <sup>c</sup> ±0.632	14.25 <sup>b</sup> ±0.5	7.143 <sup>c</sup> ±0.854
Second treatment (T2) group: Male infertile rats were transplanted with stem cells from hypoxia culture (O <sub>2</sub> 1% concentration) for 4 days with a dose of 200 million cells/rat	27.143 <sup>b</sup> ±1.433	31.15 <sup>a</sup> ±1.35	65.714 <sup>b</sup> ±1.817
<sup>a,b,c,d</sup> Different superscripts in the same column was significantly different (p<0.005). HIF2 $\alpha$ =Hypoxia-inducible factor 2 $\alpha$ , SSC=Spermatogonial stem cells, PBS=Phosphate buffer saline			

**Table-2: The mean number of Sertoli cells, Leydig cells, spermatogonium, spermatocyte primary-secondary, and spermatid cells in some treatments.**

Treatments	Mean number Sertoli cells $\pm$ SD	Mean number Leydig cells $\pm$ SD	Mean number spermatogonium cells $\pm$ SD	Mean number spermatocyte primary-secondary cells $\pm$ SD	Mean number spermatid cells $\pm$ SD
Negative control (T0-) group: Normal male rats (fertile rat) were injected with 0.1 cc PBS	30.65 <sup>d</sup> $\pm$ 1.70	39.56 <sup>d</sup> $\pm$ 1.85	53.25 <sup>d</sup> $\pm$ 2.45	74.25 <sup>d</sup> $\pm$ 1.65	125.55 <sup>d</sup> $\pm$ 1.50
Positive control (T0+) group: Male infertile rats were injected with 0.1 cc PBS	5.35 <sup>a</sup> $\pm$ 1.75	7.15 <sup>a</sup> $\pm$ 1.75	14.35 <sup>a</sup> $\pm$ 1.55	30.15 <sup>a</sup> $\pm$ 1.70	12.25 <sup>a</sup> $\pm$ 1.75
First treatment (T1) group: Male infertile rats were transplanted with stem cells from normoxia culture (O <sub>2</sub>	12.95 <sup>b</sup> $\pm$ 1.60	19.35 <sup>b</sup> $\pm$ 1.65	28.35 <sup>b</sup> $\pm$ 1.45	43.45 <sup>b</sup> $\pm$ 1.45	30.50 <sup>b</sup> $\pm$ 1.30

21% concentration) for 4 days with a dose of 200 million cells/rat					
Second treatment (T2) group: Male infertile rats were transplanted with stem cells from hypoxia culture (O <sub>2</sub> 1% concentration) for 4 days with a dose of 200 million cells/rat	20.75 <sup>e</sup> ±1.80	27.85 <sup>c</sup> ±1.75	49.95 <sup>cd</sup> ±1.75	69.85 <sup>cd</sup> ±1.50	85.25 <sup>c</sup> ±1.25
<sup>a,b,c,d</sup> Different superscripts in the same column was significantly different (p<0.005). PBS=Phosphate buffer saline, SD: Standard deviation					

**Table-3: Mean fertility rate of male rat sperm±standard deviation.**

No	Treatment	Mean fertility rate (%)±SD
----	-----------	-------------------------------

1.	Negative control (T0-) group: Normal male rats (fertile rat) were injected with 0.1 cc PBS	85.25 <sup>d</sup> ±0.130
2.	Positive control (T0+) group: Male were injected with 0.1 cc PBS	0.35 <sup>a</sup> ±0.135
3.	First treatment (T1) group: Male infertile rats were transplanted with stem cells from normoxia culture (O <sub>2</sub> 21% concentration) for 4 days with a dose of 200 million cells/rat	18.30 <sup>b</sup> ±1.40
4.	Second treatment (T2) group: Male infertile rats were transplanted with stem cells from hypoxia culture (O <sub>2</sub> 1% concentration) for 4 days with a dose of 200 million cells/rat	60.10 <sup>c</sup> ±1.80
<sup>a,b,c,d</sup> Different superscripts in the same column was significantly different (p<0.005).		
PBS=Phosphate buffer saline, SD: Standard deviation		

## Figure Legends



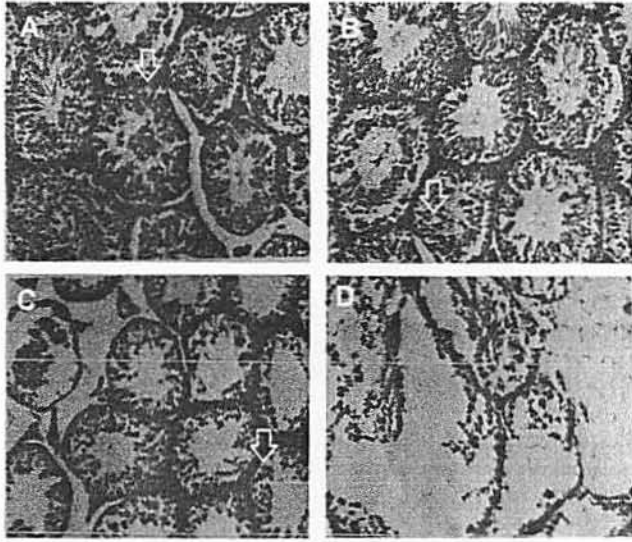

**Figure-1:** (A) P63 expression (brown) >50% in negative control (T0-) group: Normal male rats (fertile rat) were injected with 0.1 cc phosphate buffer saline (PBS); (B) p63 expression (brown) <30% in second treatment (T2) group: Male infertile rats were transplanted with stem cells from hypoxia culture (O<sub>2</sub> 1% concentration) for 4 days with a dose of 200 million cells/ rat; (C) p63 expression (brown) p63 5% in first treatment (T1) group: Male infertile rats were transplanted with stem cells from normoxia culture (O<sub>2</sub> 21% concentration) for 4 days with a dose of 200 million cells/rat; (D) The expression of p63 is zero (0%) in positive control (T0+) group: Male infertile rats were injected with 0.1 cc PBS, testis tissue was degenerate if. (A-D) Magnification 200× with the immunohistochemical method.

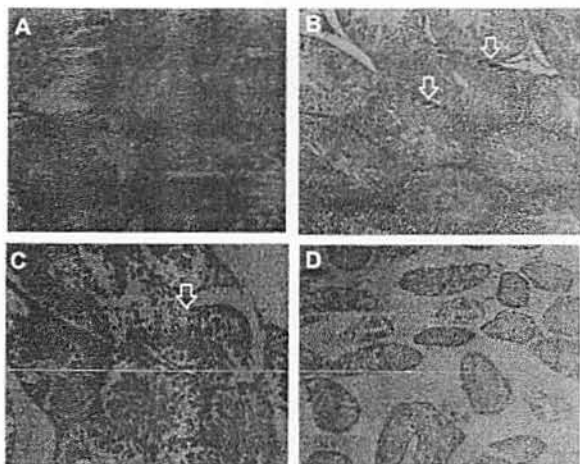

**Figure-2:** (A) No expression of hypoxia-inducible factor 2 alpha (HIF2 $\alpha$ ) (0%) in negative control (T0-) group: Normal male rats (fertile rat) were injected with 0.1 cc phosphate buffer saline; (B) HIF2 $\alpha$  expression (brown) >30% in the second treatment (T2) group: Male infertile rats were transplanted with stem cells from hypoxia culture (O<sub>2</sub> 1% concentration) for 4 days with a dose of 200 million cells/ rat; (C) HIF2 $\alpha$  expression (brown) <15% in the first treatment (T1) group: Male infertile rats were transplanted with stem cells from normoxia culture (O<sub>2</sub> 21% concentration) for 4 days with a dose of 200 million cells/rat; (D) No expression of HIF2 $\alpha$  (0%) in positive control (T0+) group: Male infertile rats were injected with 0.1 cc phosphate buffer saline. (A-D) Magnification 200 $\times$  with the immunohistochemical method.

**Lampiran 3**

**Bukti Accepted Archive Biochem & Proofread**



## Biochemical and Cellular Archives

[www.connectjournals.com/bca](http://www.connectjournals.com/bca)

Dr. P. R. Yadav  
Chief Editor

Department of Zoology  
D.A.V. (P.G.) College  
Muzaffarnagar - 251 001, India

---

Dr. Erma Safitri,  
Reproduction Veterinary Departement,  
Veterinary Medicine Faculty and  
Stem Cells Research Division of Institute Tropical Disease (ITD)  
of Universitas Airlangga  
Surabaya-Indonesia

Dated: 3 July 2018

Ref: BCA / 1078

Dear Madam,

I am pleased to inform you that your paper on "Hypotoxic precondition for induce pluripotency of rabbit's bone marrow - derived mesenchymal stem cells" by Erma Safitri, R Heru Prasetya, Mas'ud Hariadi and Fedik A Rantam has been accepted for publication in *Biochem. Cell Arch.* Your paper will appear in Vol. 18, No. 2, October 2018.

Thanking you

Sincerely yours;

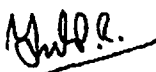
  
(P R Yadav)

---

Editorial Office : 606/8, South Civil Lines (D.A.V. College Campus), Muzaffarnagar - 251 001, India  
Ph.: 0131 - 2623278; Mobile : 09412867987 e-mail : yadavpry@rediffmail.com; submissionbca@gmail.com

## HYPOXIC PRECONDITION FOR INDUCE PLURIPOTENCY OF RABBIT'S BONE MARROW-DERIVED MESENCHYMAL STEM CELLS

Erma Safitri<sup>1,2\*</sup>, R. Heru Prasetyo<sup>3</sup>, Mas'ud Hariadi<sup>1</sup> and Fedik A. Rantam<sup>2,4</sup>

<sup>1</sup>Department of Veterinary Reproduction, Faculty of Veterinary Medicine, Universitas Airlangga, Indonesia.

<sup>2</sup>Stem Cells Research Division of Institute Tropical Disease (ITD), Universitas Airlangga, Indonesia.

<sup>3</sup>Department of Parasitology, Faculty of Medicine, Universitas Airlangga, Indonesia.

<sup>4</sup>Department of Veterinary Microbiology, Faculty of Veterinary Medicine, Universitas Airlangga, Indonesia.

\*e-mail: rma\_fispro@yahoo.com, erma-s@fkh.unair.ac.id

(Accepted 23 June 2018)

**ABSTRACT :** Hypoxic precondition *in vitro* culture can be induced of pluripotency from MSCs like hypoxia niche 1-3% in rabbit's bone marrow reside. This study was done in two phases: First phase, hypoxia precondition treatment on the stem cells culture with several O<sub>2</sub> concentration (21, 1 and 3%) and several cultivation time (1, 2, 4, 8 days); Second phase, analysis of pluripotency based on genotype expression of OCT4 and SOX2 genes after hypoxia precondition treatment. The analysis of pluripotency: expression of genotype OCT4 and SOX2 genes from the third groups sample, revealed cDNA chain at 114 bp (OCT4) and 319 bp (SOX2). But based on analyses in the same line, only 2 groups sample was found result gene sequenz of OCT4 and SOX2 code similarity with whole genom that found in gene bank was on sample that cultured with hypoxia (1% and 3% O<sub>2</sub>). The matching of OCT4 gene sequenz with the data based on similarity significance value cut off that must ≥ 60% (73% in culture 1% O<sub>2</sub> and 65% in culture 3% O<sub>2</sub>), eventhough in normoxia culture (21% O<sub>2</sub>) similarity significance value cut off < 60% (only 43%). The matching of SOX2 gene sequenz with the data based on similarity significance value cut-off ≥ 60% (85% in cultur 1% O<sub>2</sub> and 3% O<sub>2</sub>), eventhough in normoxia culture (21% O<sub>2</sub>) similarity significance value cut off < 60% (only 50%). Conclusions of this study : Hypoxic precondition (1% and 3% O<sub>2</sub>) and cultivation time (2, 4, 8 days) *in vitro* culture can be induced of pluripotency from rabbit's MSCs based on genotype expression of OCT4 and SOX2 genes with similarity significance value cut off that must ≥ 60%.

**Key words :** Hypoxia precondition, induce pluripotency, rabbit's BMSCs, genotype OCT4 & SOX2.

### INTRODUCTION

Several studies have reported that *in vitro* conventional culture of rabbit's bone marrow mesenchymal stem cells (BMSCs) with high oxygen (O<sub>2</sub>) tension (>20%), which have been considered as normoxia, frequently leads to the formation of senescence cells (Tsai *et al*, 2011), apoptosis (Wang *et al*, 2008) and a gene mutation (G: C to T: A) (Szablowska-Gadomska *et al*, 2011). This causes loss of stem cells viability before transplantation. After being transplanted, stem cells die between 93-99% on day 3 to 7 post-transplantation (Toma *et al*, 2002; Geng, 2003; Suzuki *et al*, 2004; Freyman *et al*, 2006; Sadek *et al*, 2009), even death may reach 99% on the first day post-transplantation (Wang *et al*, 2008).

Therefore, low O<sub>2</sub> tension (hypoxia) is required to support conducive microenvironment during *in vitro* culture so that the stem cells remain viable during transplantation, even may become pluripotent. In this study, hypoxia was adjusted to normal physiological

conditions needed in the place of the stem cells inside the body. The mesenchymal stem cells physiology requires integral components in the form of low O<sub>2</sub> tension of 1-3% in bone marrow (Chow *et al*, 2001), 10-15% in adipose tissue (Bizzari *et al*, 2006) and 2-9% in almost all tissues (Gruber *et al*, 2010). Therefore, we need a conducive environment for stem cells during culture process through the provision of hypoxic precondition in order to keep its form as pluripoten cells. However, until now concentration and the duration of optimal hypoxia preconditions that can be applied to BMSCs *in vitro* culture to make pluripotential cells have not been defined.

Studies on hypoxic conditioning to support *in vitro* microenvironment (niche) in several sources of stem cells have been done, such as hematopoietic stem cells (HSCs) with O<sub>2</sub> concentration of 0-5% (Arai and Suda, 2017; Suda *et al*, 2011; Simsek *et al*, 2011), later in adipose stem cells (ASCs) by 5% (Mantymaa, 2010), neural stem cells (NSCs) of 1-5% (Mantymaa, 2010) and Human

Erma Safitri *et al*

Cord Blood (HCB) of 3% for 7 days (Ivanovic *et al*, 2004). At mesenchymal stem cells (MSCs), it is done in O<sub>2</sub> concentration of 0.5-3% (Tsai *et al*, 2011; Wang *et al*, 2008; Rosova *et al*, 2008; Hu *et al*, 2008). Until now, studies are still being conducted in the search for absolute factor of *in vitro* niche that is able to control stem cells proliferation to remain viable and undifferentiated (Halim *et al*, 2010), in addition to prevent apoptosis process, the formation of senescence cells or gene mutations. If it can be materialized, even with *in vitro* pluripotency, the availability of stem cells may be produced easily by researchers and clinicians as a key ingredient in cell transplantation therapy (Masarani *et al*, 2006; Kilani, 2009).

However, the lack of viability in the form of short term maintenance conditions (Takubo, 2011) of the stem cells to be transplanted to patients with degenerative disease or injury causes the effectiveness of this therapy be limited (Masarani *et al*, 2006). This can be explained as follows: physiological environment of stem cells in the body requires low O<sub>2</sub> levels (hypoxia), whereas *in vitro* culture has been carried out under normoxia. Therefore, a hypoxic environment needs to be created during *in vitro* culture of the stem cells to adjust to the physiological microenvironment where the stem cells stay.

Target genes *in vitro* culture are expected to lead to the expression of pluripotency genes (Grskovic and Santos, 2008), such as OCT4, SOX2, NANOG (Szablowska-Gadomska *et al*, 2011; Neganova *et al*, 2016), REX-1 (Kolf *et al*, 2007), KLF-4 and c-MYC (Neganova *et al*, 2016; Takahashi *et al*, 2007). However, it remains unclear how to create pluripotency cells *in vitro* hypoxic precondition culture before the stem cells are transplanted. Therefore, this study was conducted to determine O<sub>2</sub> concentration (whether 21, 1, or 3%) and time (whether 1, 2, 4 or 8 days) of hypoxic preconditioning needed to achieve pluripotency stem cells.

## MATERIALS AND METHODS

### Hypoxic preconditioning in Rabbit's BMSCs culture

Isolated cells from Rabbit's BMSCs (Rabbit strain New Zealand) have been isolated, grown up to the third passage. The cells were taken aseptically and then placed on a culture disk with a density of  $2 \times 10^7$  cells/cm<sup>2</sup> at 10 dishes with a diameter of 5 cm<sup>2</sup>. The medium culture with IMDM, this medium was containing 15% FBS, BMSCs simulator supplements and antibiotics (100 U penicillin/100 ug/mL streptomycin) at a temperature of 37°C, 5% CO<sub>2</sub> and 95% air (Rantam and Ferdiansyah, 2014). Treatment at BMSCs cells was done by providing

hypoxic conditions in several doses of O<sub>2</sub> (21, 1 and 3%) concentrations by integrating culture flask into a specialized incubator for hypoxic conditions (Modular Incubator Chamber) cultured for 1, 2, 4, 8 days (cultivation time).

At this stage the samples MSCs were divided into three treatment groups each of 10 replications, namely: T0 group (Control): The third passage of MSCs, in normoxia precondition (O<sub>2</sub> = 21%) for 1, 2, 4, and 8 days; Treatment group 1 (T1): the third passage of MSCs were given hypoxia precondition (O<sub>2</sub> = 1%) for 1, 2, 4, and 8 days; and the treatment group 2 (T2): the third passage of MSCs were given hypoxia precondition (O<sub>2</sub> = 3%) for 1, 2, 4, and 8 days

### Analyses of pluripotency induction

Analysis of pluripotency induction was based on the expression of genes such as OCT4 and SOX2 genotypically by PCR and DNA sequencing.

### OCT4 & SOX2 coding gene expression using PCR and DNA sequencing

#### Polymerase Chain Reaction (PCR) of OCT4 dan SOX2

After hypoxic precondition treatment, PCR stages of OCT4 and SOX2 was done through several procedures, such as RNA extraction, spectrophotometer, cDNA, PCR, PCR product analysis through electrophoresis process and DNA visualization (Rantam and Ferdiansyah, 2014; Martin *et al*, 2013).

RNA extraction of from cultured cells. Cultured cells as many as 10<sup>3</sup> cells in Eppendorf stored in minus 20°C were removed and left at room temperature until the condition was not frozen. Centrifugation was done at 12,000 rpm for 10 minutes, then the supernatant was discarded. Furthermore, pellet resuspension was made with 200 PBS and 400 µL of lysis buffer was added and vortexed for 15 seconds. Then, samples were transferred to the filter by pipetting, then centrifugated 8000 g for 1 minute. The next process, 90 µL DNase was taken with a pipette and the buffer was incubated in sterile Eppendorf, then 10 µL DNase was added, mixed and put in the filter, and then incubated for 15 minutes at room temperature and added with 500 mL wash buffer I and centrifuged 8000 g for 15 seconds. Then, 500 mL wash buffer II was added again and centrifuged 8000 g for 15 seconds as well. As much as 200 mL wash buffer II was added again but centrifuged 13,000 g for 2 minutes. The next stage, the filter was transferred to a new Eppendorf tube and RNA elution was carried out with 50-100 elution buffer. Furthermore, it was centrifuged 8000 g for 1 minute and the RNA was stored at -80°C (Rantam and

### Hypoxic precondition for induced pluripotency of rabbit's bone marrow-derived mesenchymal stem cells

Ferdiansyah, 2014).

Spectrophotometer was done to observe RNA purity and RNA levels to be amplified by PCR. A total of 10 mL samples, which have been added with 690 mL distilled water, was prepared and then vortexed. Subsequently the samples were transferred to the corresponding cuvettes of the spectrophotometer and the results were observed at wavelengths  $\lambda = 260$  and  $\lambda = 280$  (Martin *et al.*, 2013).

cDNA is DNA synthesis stage that must be passed before PCR amplification. At this stage the obtained RNA was included in 0.5 ml eppendorf tube and stored in a heating block 65°C for 10 minutes to denature the RNA. The next process to obtain cDNA was that each sample was added with 10  $\mu$ l MMX, which consists of tube 1 = 4.4  $\mu$ l tubes; tube 1 = 4  $\mu$ l; tube 2 = 0.2  $\mu$ l; tube 3 = 0.4  $\mu$ l; tube 4 = 0.4  $\mu$ l; tube 5 = 0.6  $\mu$ l, mixed up down, not vortexed (Rantam and Ferdiansyah, 2014).

**PCR amplification :** PCR principle consists of three phases, denaturation of double-stranded DNA, primer annealing to DNA targets and primer extension by the presence of DNA polymerase. Resulted DNA is the exponential accumulation of specific target DNA. Three stages in the amplification are: 1. cDNA denaturation stage, performed by incubating on a heating block at 37°C for 60 minutes, followed by 65°C for 10 minutes and keeping in the fridge overnight for further PCR process. Synthesized cDNA results were added with PCR mix each 12.5  $\mu$ l. PCR mix consists of tag polymerase, ion buffers MgCl<sub>2</sub>+ and dNTP; 2. Annealing stage is the attachment of the primer to the template, primers OCT4 (Oligo-Macrogen) with 5'-AGC OCT4f = AAA ACC CGG AGG AGT-3' (18mer) and OCT4r = 5'-CCA CAT TAT GTG CGG CCT ATC-3' (21mer) and SOX2 primer (Oligo-Macrogen) with SOX2f = 5'-TTG CTG CCT CTT GAC TAA TAG GA-3' (23mer) and SOX2r = 5'-CTG GGG AAA CTT CTC CTC TC-3' (20mer) respectively of 2.5  $\mu$ l; 3. The final stage is the primer extension, the lengthening process of nucleotide base strand. This process is done by adding annealing results on phase 2 with a sample of OCT-4 and SOX2 each 7.5  $\mu$ l. This process is carried out at a temperature of 65°C in a heating block for 2 hours with the aim to form two new DNA double strands. The amplification process can be seen in Table 1 (Safitri *et al.*, 2014).

**Analysis of PCR products.** cDNA PCR products that have been amplified through several phases above were then visualized using UV rays to obtain cDNA strand at specific base pair. To obtain the base pair, we previously performed electrophoresis on 2% agarose gel + 0.5 TBE

using ethidium bromide staining. Furthermore, the PCR product is undergoing sequencing a process to obtain nucleotide sequences.

#### DNA sequencing

Stages of DNA sequencing of OCT4 and SOX2 after hypoxic preconditioning is done through several procedures, *ie.* PCR product purification, labeling, precipitation and sequencing as well as software analysis of the sequencing results.

In the purification of PCR products, one volume produced by PCR was added with 5 volumes of PBS, then added with 10 v of sodium acetate 3 M pH 5. Furthermore, as DNA binding, the sample was put on QIA quick column and centrifuged at 13,000 rpm for 1 minute. Supernatant resulting from centrifugation was then discarded. Thereafter, it was added with 75  $\mu$ l PE buffer and centrifuged at 13,000 rpm for 1 minute. The supernatant was discarded and then centrifuged again for 1 minute at a speed of 14,000 rpm. QIA quick column was placed in 1.5 ml Eppendorf tube, then added with 30  $\mu$ l EB buffer right in the middle of the column and centrifuged for 1 minute. The supernatant was then removed and transferred to a new tube.

In labeling, we made reagents mixture consisting of 4 ml of Ampli Tag RNA polymerase, sequencing buffer, dNTPs, dye labeled terminators, 21 mL of purified PCR product, 1.5 mL primers and coupled with ddH<sub>2</sub>O up to volume 15  $\mu$ l, then vortexed.

During precipitation, sequencing product of 15  $\mu$ l each was added with 1.5 mL EDTA, 125 Mm pH 8, 1.5  $\mu$ l of 3M sodium acetate pH 2.5 and 37.5 mL of absolute ethanol then vortexed and incubated at 4°C. Samples were wrapped in aluminum foil to avoid light and stored in a refrigerator at a temperature of -20°C.

**Sequencing :** DNA base sequence can be determined by sorting appearing fragments starting from the bottom (the shortest). The instrument used was ABI 3110 Capillary Sequencer XI. DNA fragments can be visualized as primers labeled with fluorescence. The result of such sequencing is in the form of electropherogram.

Sequencing results were analyzed using software Bioedit and BLAST (Basic Local Alignment Search Tool). Analysis of Bioedit results used Sequence Alignment Editor program that aims to analyze bioinformatics sequence of DNA, RNA and protein. One of the stages is the procedures for doing sequence alignment with readings in both directions (forward-reverse) to sequence a DNA (Schwartz and Pachter, 2007).

Erma Safitri *et al*

The sequence obtained from this study can be analyzed by comparing available data with the already published data in Gene Bank database. One form of analysis is the sequence alignment. Sequence alignment may be used to compare two or more sequences to assist in differentiating bases. The program used for sequence alignment is Bioedit and BLAST. The function of the programs is to analyze sequence data, comparing the sequence studied with databases of various different strains from various countries and to see the matches of a sample from its base sequence (query confidence) (Thomsen *et al*, 2017).

#### Data analysis

Genotype expression results were analyzed by PCR and DNA sequencing, which in this study was observed descriptively. Phenotype expressions analyzed were those on OCT4 and SOX2 as two markers of pluripotency induction of stem cells, whereas genotype observations was done on the OCT4 and SOX2.

### RESULTS

#### Genotype expression of genes OCT4 and SOX2 (PCR and DNA sequencing)

After cultured with hypoxic preconditioning treatment, OCT4 and SOX2 genotype characterization of BMSCs underwent PCR-DNA sequencing method. The aim of this characterization was to obtain the expression of OCT4 and SOX2-encoding genes, which were expressed in immunofluorescence at 48 hours of treatment (1% and 3% O<sub>2</sub>), but were not expressed at 21% O<sub>2</sub>. In this study the expression of OCT4 and SOX2 appeared after 2 days of treatment of hypoxic preconditioning. This indicated that the cultivation time of hypoxia preconditioning was capable of causing the expression of OCT4 and SOX2 as a transcription factor and that MSCs were pluripotent and self-renewal. PCR results of OCT4 with PCR product was 114 base pair (bp) (Fig. 1) and SOX2 was up to 319 base pair (bp) (Fig. 2).

cDNA strand shown in both figures indicate MSCs cell count concentration sufficient to express the OCT4 and SOX2 encoding gene. Subsequently, we performed purification of PCR products, then labelled and sequenced to obtain the nucleotide composition of the OCT4 and SOX2 encoding gene.

#### Characterization OCT4 and SOX2 by DNA Sequencing

Sequencing DNA will produce DNA sequence as described through a string of letters symbolizing nucleotides as DNA elements, such as ACGT. This sequencing technique uses a method known as the Sanger

method, a method that uses the termination or end of the DNA synthesis reactions that are specific to particular sequences by using nucleotides. DNA chain elongation at the Sanger method begins in a specific area of DNA template by using primers. The primer will be complementary to the DNA from the sample as the target of observation. Sequencing is done for the characterization of MSCs genotypically after MSCs culture with hypoxic preconditioning with the aim of obtaining OCT4 and SOX2 coding genes nucleotide base arrangement expressed by MSCs.

The results of the visualization of raw sequencing electropherogram results of sequencing using the primer OCT4 (Oligo-Macrogen) with 5'-AGC OCT4f = AAA ACC CGG AGG AGT-3 '(18mer) and OCT4r = ' 5-CCA GTG CCT TAT CAT CGG ATC-3 '(21mer) and SOX2 primer (Oligo-Macrogen) with 5'-GCT SOX2f = CTC CAA AGT GCG ACG AA-3' (20mer) and SOX2r = '5-AAG AAA AGT GGC TTT CTG AGA TA-3' (23mer).

Nucleotide bases arrangement shown in electropherogram of sequencing results of the samples after hypoxic preconditioning revealed that the primary base encoded by OCT4 and SOX2 shows the amplified DNA had a good purity. Based on the results of the amplification, analysis of the sequencing results can be followed with Bioedit using Sequence Alignment Editor for analyzing bioinformatics of DNA sequence, RNA and protein.

The series of sequencing analysis was carried out in several stages, beginning with a sequence alignment (alignment analysis) in order to compare two or more sequences that different bases can be easily seen. This alignment analysis phase uses special program that the Bioedit and BLAST (Basic Local Alignment Search Tool). The program analyzes data from sequences, comparing studied sequences with database of various types of different transcription factors and to find matches sample a from its base sequence (query confidence). The results of sequencing analysis, alignment analysis and OCT4 whole genome in this study can be seen in Fig. 3.

Based on the analysis of OCT4 encoding gene by PCR after hypoxic preconditioning (1% and 3% O<sub>2</sub>), which was compared to normoxia (21% O<sub>2</sub>) and visualized using electrophoresis on 2% agarose gel by with ethidium bromide, three samples showed cDNA strand of 114 bp (Fig. 1). However, alignment analysis showed only 2 matches between the results of OCT4 encoding gene sequences with whole genome samples in gene banks (Fig. 3). Both matched data were on samples cultured with hypoxia (1% O<sub>2</sub> and 3% O<sub>2</sub>).



Hypoxic precondition for induced pluripotency of rabbit's bone marrow-derived mesenchymal stem cells

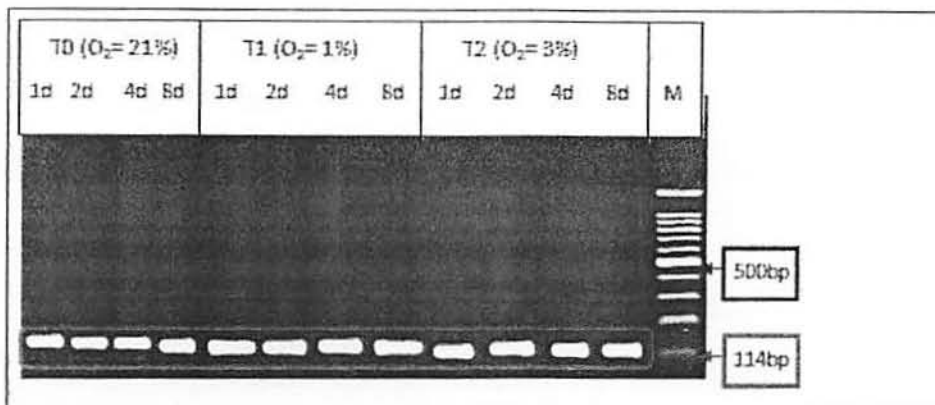

Fig. 1 : OCT4 encoding gene analysis with PCR after hypoxic preconditioning treatment (1% and 3% O<sub>2</sub>) compared with normoxia (21% O<sub>2</sub>) visualized electrophoresically in 2% agarose gel with ethidium bromide staining. The result reveals cDNA strand of 114 bp. M = marker.

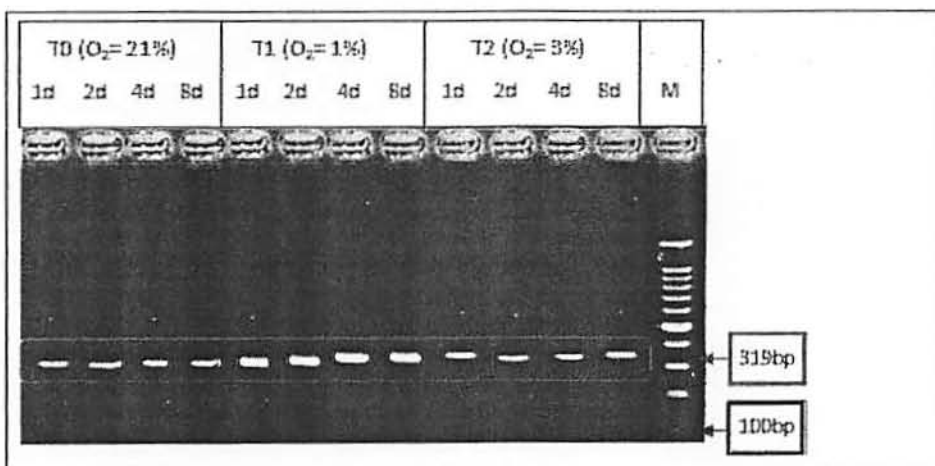

Fig. 2 : SOX2 encoding gene analysis with PCR after hypoxic preconditioning treatment (1% and 3% O<sub>2</sub>) compared with normoxia (21% O<sub>2</sub>) visualized electrophoresically in 2% agarose gel with ethidium bromide staining. The result reveals cDNA strand of 319 bp. M = marker.

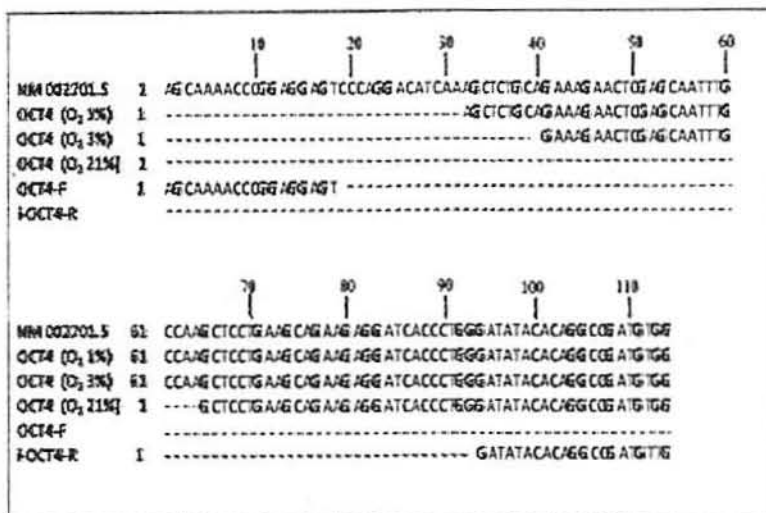

Fig. 3 : OCT4 sequencing analysis using multiple alignment. NM 002701.5 → OCT4 whole genome.

Compatibility data was based on similarity significance of the cut-off value that should be  $\geq 60\%$  (73% in cultures of 1% O<sub>2</sub> and 65% at 3% O<sub>2</sub> culture), whereas in normoxia culture (21% O<sub>2</sub>) similarity significance cut-off value  $< 60\%$  (only 43%). The results of sequencing analysis, alignment analysis, and whole genome OCT4 in this study can be seen in Fig. 3.

Based on the analysis of SOX2 encoding gene by PCR after hypoxic preconditioning (1% and 3% O<sub>2</sub>), compared to normoxia (21% O<sub>2</sub>) and visualized in electrophoresically on 2% agarose gel by ethidium bromide staining, three samples showed cDNA strand of 319 bp (Fig. 2). However, based on the analysis of the data alignment there were 2 data resulting from the sample's SOX2 encoding gene sequences that match with the whole genome in the gene bank (figure 4). Both data were on hypoxic cultured samples (1% O<sub>2</sub> and 3% O<sub>2</sub>). Data matching was based on similarity significance cut-off value that should be  $\geq 60\%$  (85% in cultures of 1% O<sub>2</sub> and 85% at 3% O<sub>2</sub> culture), whereas in normoxic culture (21% O<sub>2</sub>) similarity significance cut-off value was  $< 60\%$  (only 50%) (Fig. 4).

In this study, the expression of OCT4 and SOX2 in hypoxic preconditioning 1% and 3% O<sub>2</sub>, respectively occurred on day 2 and 4, while that in normoxia did not appear. This indicated that the cultivation time (number of days) of hypoxic preconditioning may cause the expression of OCT4 and SOX2 as a transcription factor so that MSCs became pluripotential. PCR result of OCT4 revealed 114 base pair (bp) (Fig. 1) and SOX2 as many as 319 base pair (bp) (Fig. 2).

Based on the analysis of the OCT4 and SOX2 encoding gene by PCR after hypoxic preconditioning (1% and 3% O<sub>2</sub>) compared to normoxia (21% O<sub>2</sub>) and visualized in electrophoresis on 2% agarose gel with ethidium bromide staining, three samples showed the cDNA strand of 114 bp (Fig. 1) and 319 bp (Fig. 2). However, based on the analysis of the data alignment revealed only 2 results of OCT4 and SOX2 encoding gene sequences samples matched with whole genome in the gene bank (Fig. 3). Both matches are on samples with hypoxic culture (1% O<sub>2</sub> and 3% O<sub>2</sub>). Compatibility data was based on significance value similarity that must have cut-off value  $\geq 60\%$ . In OCT4 sample, 73% in 1% O<sub>2</sub> culture and 65% at 3% O<sub>2</sub> culture, in normoxia culture (21% O<sub>2</sub>) similarity significance cut off value was  $< 60\%$  (only 43%). In SOX2 sample, 85% in 1% O<sub>2</sub> culture and 3% O<sub>2</sub>, whereas in normoxia culture (21% O<sub>2</sub>) similarity significance cut-off value was  $< 60\%$  (only 50%).

## DISCUSSION AND CONCLUSION

The results of pluripotency analysis based on genotype expression of OCT4 and SOX2 genes by PCR and DNA sequencing and phenotypically with immunofluorescence in this study were in line with the results of the study of Covello *et al* (2006) and Forristal *et al* (2010), who found that after 48 hours of hypoxic administration in cultured stem cells HIF2- $\alpha$  expression will be produced directly to become upstream regulator of OCT4 transcription factors, which is essential for maintaining pluripotency. Likewise, another transcription factor, such as SOX2 and Nanog, are also regulated by HIF2- $\alpha$  (Forristal *et al*, 2010). Furthermore, Yu *et al* (2007) wrote that these three transcription factors, OCT4, SOX2 and Nanog, maintain stemness and suppress genes that cause differentiation. OCT4 and SOX2, two of the four transcription factors introduced by Takahashi *et al* (2006), were firstly found in iPS (induced Pluripotent Stem) cells program.

According to Yoshida *et al* (2009), the relationship between hypoxia, HIF2- $\alpha$  and pluripotency genes such as OCT4, SOX and Nanog are crucial to induce pluripotent stem cells, because it has been proved that hypoxia increases efficiency and reprogramming. The study by Zadori *et al* (2009) in NSCs transplantation indicates that preconditioning of hypoxic environment was also necessary for the process of *in vitro* culture. Replacement therapeutic effectiveness of stem cells requires knowledge on the mechanisms that affect stem cells early development, such as migration, proliferation and stem cells commitment (Wu *et al*, 2008) and the dependence on oxygen levels in the appropriate environmental conditions. There is a clear functional relationship between hypoxia inducible factor and stemness with transcription factors altogether *in vivo*. The niche of NSCs is hypoxic conditions that create high reliance on early development process at oxygen level.

The results of this study, that pluripotency activity after hypoxic treatment on days 2 and 4 through OCT4 and SOX2 expression, genetically support one of the main focuses in the research of adult stem cells *in vitro*. This is because *in vivo* we need balance between differentiation, apoptosis and self renewal of stem cells. The balance is regulated by one of microenvironment niche where stem cells are located. According to Barria *et al* (2004) in feeder-free *in vitro* culture, the fate of stem cells in influencing balance between self-renewal, differentiation and apoptosis, in addition of being affected by growth factor, interleukins or serum, also influenced by the conditions given during the culture process, which in this study was hypoxic conditions 1 and 3%.

Hypoxic precondition for induced pluripotency of rabbit's bone marrow-derived mesenchymal stem cells

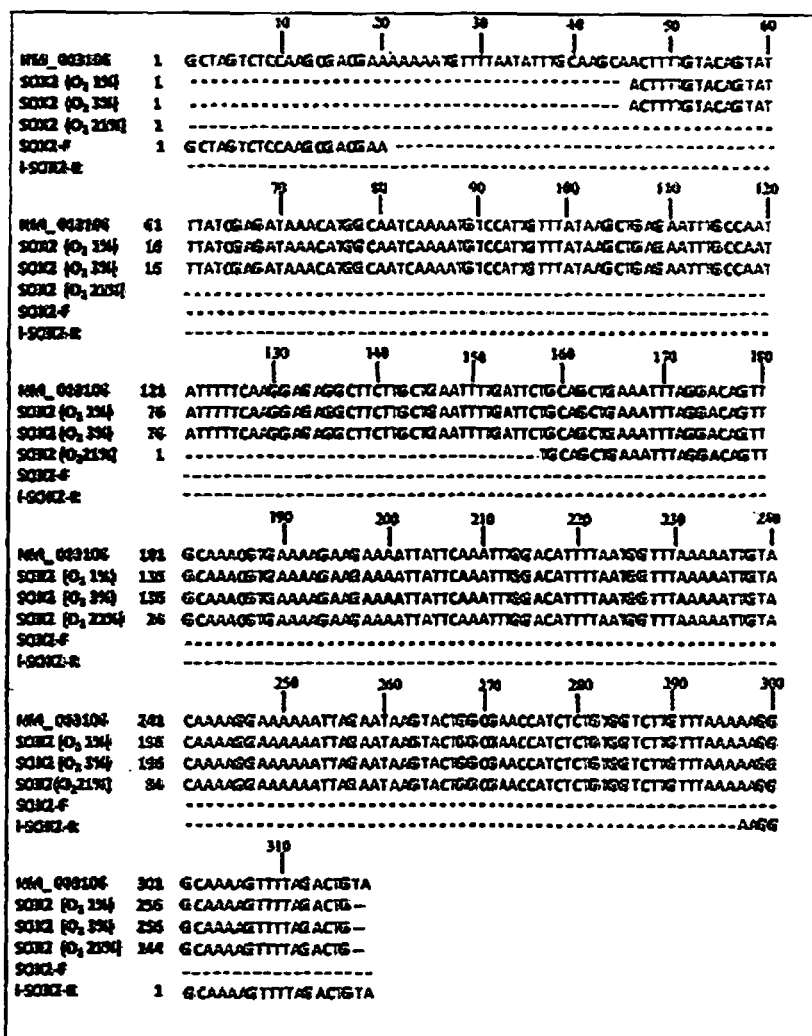

Fig. 4 : SOX2 sequencing analysis using multiple alignment. NM 003106 → SOX2 whole genome.

Table 1 : BMSCs PCR cycle in the heating block (Safitri *et al.*, 2014).

No	Temperature	Time	Notes
1.	Room	15 minutes	RNA Predenaturation
2.	65°C	10 minutes	RNA Denaturation
3.	37°C	60 minutes	DNA Denaturation
4.	65°C	10 minutes	Advanced DNA Denaturation
5.	65°C	2 hours	Extension
6.	4°C (refrigerator)	10 minutes	Soaking

Pluripotency is the potential to differentiate into any cell of the body of the three embryonic layers (ectoderm, mesoderm and endoderm). Potential to become these three embryonic layers is in general are characteristics possessed by embryonal stem cells (ESCs) (Szabłowska-Gadomska, 2011). According to Halim *et al.* (2010), compared to progenitor cells that have unipotent properties,

stem cells, in particular ESCs, has potential far greater differentiation. ESCs, derived from the inner cell mass (ICM) in blastocyst are pluripotent, so as to differentiate into various types of cells making up the body of the three embryonic layers, including nerve cells, blood cells, the cells making up the heart and immune system cells. In this study, MSCs, which are adult stem cells that are generally well characterized as multipotent, can express OCT4 and SOX2 genes, both genetically and phenotypically (Safitri *et al.*, 2016; Prasetyo and Safitri, 2016) after being treated as hypoxic during *in vitro* culture. Therefore, in the future it is suspected that MSCs with hypoxic preconditioning have pluripotent potential. This suspicion is confirmed by the opinion of some studies (Takahashi *et al.*, 2007; Yu *et al.*, 2007; Takahashi and Yamanaka, 2006; Moheyldin *et al.*, 2010), that the efficiency of reprogramming in iPS cells in hypoxic conditions is very high.

## SUMMARY

Hypoxic precondition *in vitro* culture can be induced of pluripotency from MSCs like hypoxia niche 1-3% in rabbit's bone marrow reside. The matching of OCT4 gene sequenz with the data based on similarity significance value cut off 73% in culture 1% O<sub>2</sub> and 65% in culture 3% O<sub>2</sub>, eventhough in normoxia culture 21% O<sub>2</sub> similarity significance value cut off only 43%. The matching of SOX2 gene sequenz with the data based on similarity significance value cut-off 85% in cultur 1% O<sub>2</sub> and 3% O<sub>2</sub>, eventhough in normoxia culture 21% O<sub>2</sub> similarity significance value cut off only 50%. Conclusions of this study : Hypoxic precondition 1% and 3% O<sub>2</sub> and cultivation time 2, 4, 8 days *in vitro* culture can be induced of pluripotency from rabbit's MSCs based on genotype expression of OCT4 and SOX2 genes with similarity significance value cut off that must ≥ 60%.

## REFERENCES

- Tsai C C, Chen Y J, Yew T L, Chen L L, Wang J Y and Chiu (2011) Hypoxia inhibits senescence and maintains mesenchymal stem cell properties though down-regulation of E2A-p21 by HIF-TWIST. *Blood* 117, 4679-4692.
- Wang J, Chen T L, Jiang J Shi H, Gui C, Luo R H (2008) Hypoxic preconditioning attenuates hypoxia/ reoxygenation-induced apoptosis in mesenchymal stem cells. *Acta Pharmacologica Sinica* 29, 74-782.
- Szablowska-Gadomska I, Zayat V and Buzanska L(2011) Influence of low oxygen tension on expression of pluripotency genes in stem cells. *Acta Neurobiologiae Experimentalis* 71, 86-93.
- Toma C, Pittenger M F and Cahill K S (2002) Human mesenchymal stem cells differentiate to a cardiomyocyte phenotype in the adult murine heart. *Circulation* 105, 93-98.
- Geng Y J (2003) Molecular mechanisms for cardiovascular stem cell apoptosis and growth in the hearts with atherosclerotic coronary isease and ischemic heart failure. *Annals of the New York Academy of Sciences* 1010, 687-697, 2003.
- Suzuki K and Murtuza B and Beauchamp J R (2004) Dynamics and mediators of acute graft attrition after myoblast transplantation to the heart. *The FASEB Journal* 18, 1153-1155.
- Freyman T Polin G and Osman H (2006) A quantitative, randomized study evaluating three methods of mesenchymal stem cell delivery following myocardial infarction. *European Heart J.* 27, 1114-1118.
- Sadek H A, Martin C M and Latif S S (2009) Bone marrow derived side population cells for myocardial regeneration. *J. Cardiovascular Translational Res.* 2, 173-181.
- Chow D C, Wenning L A, Miller W M and Papoutsakis E T (2001) Modelling pO<sub>2</sub> distributions in the bone marrow hematopoietic compartment. II. Modified Kroghian models. *Biophysical J.* 81, 685-896.
- Bizzari A, Koehler H, Cajlakovic M, Pasic A, Schaupp L and Klimant I (2006) Continuous oxygen monitoring in subcutaneous adipose tissue using microdialysis. *Analytica Chimica Acta* 573, 48-56.
- Gruber M, Mathew L K, Runge A C, Garcia J A and Simon C (2010) Epas is required for spermatogenesis in the postnatal mouse testis. *Biology of Reproduction* 82, 1227-1236.
- Arai F and Suda T (2017) Quiescent stem cells in the niche. *Stembook* (Ed), 2006. The Stem Cell Research Community. StemBook, doi/10.3824/stembook.1.6.1. <http://www.stembook.org>. Access on: 19 Dec. 2017.
- Suda T, Takubo K and Semenza G L (2011) Cell Stem Cell Review. Metabolic regulation of hematopoietic stem cells in hypoxic niche. *Cell Stem* 9, 296-310.
- Simsek T, Kocabas F, Zhen G J, De-Beraedinins R, Mahmoud A I and Olson E N (2011) The distinct metabolic profile of hematopoietic stem cells reflects their location ina hypoxic niche. *Cell Stem Cell* 7, 380-390.
- Mantymaa A (2010) The effects of hypoxic conditions on the chondrogenic differentiation of adipose stem cells. Master's Thesis. Institute of Medical Technology, University of Tampere.
- Mannello F, Medda V and Toni G A (2011) Hypoxia and neural stem cells : from invertebrates to brain cancersystem cells. *Int. J. Develop. Biol.* 55, 569-581.
- Ivanovic Z, Hermite F, De La Grange P B, Dazey B, Belloc F and Lacombe F (2004) Simultaneous maintenance of human cord blood scid-repopulating cells and expansion of committed progenitors at low O<sub>2</sub> concentration (3%). *Stem Cells* 22, 716-724.
- Rosova I, Dia A O M, Cappocia B, Link D, Nolta J A (2008) Hypoxic preconditioning results in increased motility and improved therapeutic potential of human mesenchymal stem cell. *Stem Cells* 26, 2173-2182.
- Hu X, Yu S P, Fraser J L, Lu Z, Mc-Ogie and Wang J A (2008) Transplantation of hypoxia-preconditioned mesenchymal stem cells improves infarcted heart function via enhanced survival of implanted cells and angiogenesis. *The J. Thoracic. Cardiovascular Surgery* 135, 799-808.
- Halim D H, Murty F, Sandra A, Boediono T, Djuwantono B and Setiawan B (2010) *Stem Cell Dasar Teori dan Aplikasi Klinis*. 1<sup>st</sup> Ed. Jakarta, Indonesia: Penerbit Erlangga, 2010
- Masarani M, Wazait H and Dinneen M (2006) Mumps ocrchitis. *J.e Royal Social Medicine* 99, 573-575.
- Kilani Z (2009) Stem cell transplantation in human testis for the treatment of male infertility, 2009. ISRCTN75604065. <http://www.farah-hospital.com>. Acces on: Dec 2017 2009.
- Takubo K (2011) The hypoxia regulatory system in hematopoietic stem cells. *Adv.Hematopoetik Stem Cell Res.* 11, 133-146.
- Grskovic M and Santos M R (2008) The pluripotent transcriptome. The Stem Cell Research Com. StemBook. doi:10.3824/stembook.1.24.1, 2008
- Yamanaka S (2007) Strategies and new developments in the generation of patient-specific pluripotent stem cells. *Cell Stem Cell Review. Journal Stem* 05, 12.
- Kolf C M, Cho E and Tuan R S (2007) Review Mesenchymal Stromal. Biology of adult mesenchymal stem cells : regulation of niche, self-renewal and differentiation. *Arthritis Res. Therapy* 9, 204.
- Neganova I, Shmeleva E, Munkley J, Chichagova V, Anyfantis G and Anderson R (2016) JNK/SAPK signaling is essential for efficient reprogramming of human fibroblasts to induced pluripotent stem cells. *Stem Cells* 34, 1198-1212.
- Takahashi K, Tanabe K and Ohnuki M (2007) Induction of pluripotent stem cells from adult human fibroblasts by defined factors. *Cell* 131, 861-872.

## Hypoxic precondition for induced pluripotency of rabbit's bone marrow-derived mesenchymal stem cells

- Rantam F A, Ferdiansyah, Purwati (2014) Stem cells mesenchymal hematopoetik dan model aplikasi. 2<sup>nd</sup> (Ed). Surabaya, Indonesia: Airlangga University Press.
- Marti N I, Garcı'AT, Fajardo V, Lo'Pez-Calleja I, Rojas M and PAVON M A (2013) Technical note: Detection of chicken, turkey, duck, and goose tissues in feedstuffs using species-specific polymerase chain reaction. *J. Animal Sci.* 85, 452-458.
- Safitri E, Utama S, Bumi C, Aulani'AM and Rantam F A (2014) Hypoxic preconditioning for viable and self renewing mesenchymal stem cells (MSCs) as the regeneration of spermatogenesis process. *Adv. Natural and Appl.Sci.* 8, 42-46.
- Schwartz A S and Pachter L (2007) Multiple alignment by sequence anneling. *Bioinformatics* 23(2), e24-e29.
- Thomsen R, Gary B, Fogel T and Krink H (2002) A clustal alignment improver ing evolutionary algorituhms. 0-7803-7282-4/02/IEEE. Access on: 23 Sep. 2017.
- Covello K L, Kehler J, Yu H, Gordan J D, Arsham A H andHu C J (2006) HIF2 regulates Oct4: effect of hypoxia on stem cell function, embryonic development, and tumor growth. *Genes Develop.* 20, 557-570.
- Forristal C E, Wright K L, Hanley N A, Oreffo O and Houghton F D (2010) Hypoxia inducible factor regulate pluripotency and proliferation in human embryonic stem cells cultured at reduced oxygen tensions. *Reproduction* 139, 85-97.
- Yu J, Vodyanik M A, Smugo-Otto K, Antosiewicz-Bourget J, Frane J and Tians S (2007) Induced pluripotent stem cells line derived from human somatic cells. *Science* 1011, 1-4.
- Yoshida Y, Takahash K, Okita K, Ichisaka T, Yamanak S (2009) Hypoxia enhances the generation of induced pluripotent stem cells. *Cell Stem Cell* 5, 237-241.
- Zadori A, Agoston V A, Demeter K, Hadinger N, Varady L and Kohidi (2011) Stem cells properties at different oxygen levels. *Experimentalis Neurology* 227, 136-148.
- Wu J, Sun Z and Sun S (2008) Intravenously administered bone marrow cells migrate damaged brain tissue and improve neural function in ischemic rats. *Cell Transplantation.* 16, 993-1005.
- Barria E, Mikels A and Haas M (2004) Maintenance and self-renewal of long-term reconstituting hematopoietic stem cells supported by amniotic fluid. *Stem Cells Develop.* 13, 548-562.
- Safitri E, Utama S, Widiyatno T V, Sandhika W, Prasetyo R H (2016) Autoregeneration of mice testicle seminiferous tubules due to malnutrition based on stem cells mobilization using bee honey. *Asian Pacific J. Reprod.* 5 30-34.
- Prasetyo R H and Safitri E (2016) Effect of Honey to Mobilize Endogenous Stem Cells in Effort Intestinal and Ovarian Tissue Regeneration in Rats with Protein Energy Malnutrition. *Asian Pacific J. Reprod.* 5, 198-203.
- Takahashi K and Yamanaka S (2006) Induction of pluripotent stem cells from mouse embryonic and adult fibroblast cultures by defined factors. *Cell* 126, 663-676.
- Mohyeldin A, Muvdi T G and Hiojosa A Q (2010) Cell Stem Cell Review. oxygen in stem cell biology: a critical component of the stem cell niche. *Cell Stem Cell* 7, 150-161.

**Lampiran 3**

**Bukti Accepted Philippine Journal of Veterinary Science**

**ORIGINAL ARTICLE****VIABILITY OF RABBIT ADIPOCYTE STEM CELLS CULTURED UNDER DIFFERENT OXYGEN CONCENTRATIONS *IN VITRO***

Erma Safitri<sup>1</sup>, Pudji Srianto<sup>1</sup>, Thomas Valentinus Widiyatno<sup>1</sup>,  
Willy Sandhika<sup>2</sup> and R. Heru Prasetyo<sup>\*2</sup>

<sup>1</sup>*Faculty of Veterinary Medicine; <sup>2</sup>Faculty of Medicine, Universitas Airlangga, Surabaya, East Java, Indonesia*

**ABSTRACT**

The aim of this research was to determine if rabbit adipocyte stem cells (r-ASCs) can still be viable before transplantation when these are cultured *in vitro* under hypoxic preconditioning (3% O<sub>2</sub> concentration). Samples were divided into two groups, one under hypoxic preconditioning and the other in hyperoxia (20% O<sub>2</sub> concentration). Observations were made through flow cytometry, immunofluorescence and immunocytochemical analyses. Flow cytometric analysis showed that in r-ASCs hypoxic culture, the levels of CD90+, CD44+ and CD45- were unaltered, but changed under hyperoxic culture, indicated by the down-regulation of CD90+ and CD44+, and up-regulation of CD45-. Meanwhile, immunocytochemical and immunofluorescence analysis showed that under hypoxic preconditioning, r-ASCs culture expressed quiescent cells with p63 as marker, but the latter remained unexpressed in hyperoxic culture. In conclusion, hypoxic preconditioning with 3% O<sub>2</sub> concentration supported r-ASCs in sustaining viability before transplantation in rabbit.

**Key words:** hyperoxia, hypoxic preconditioning, rabbit, r-ASCs, viability

*Philipp. J. Vet. Med., 55(SI): 1-8, 2018*

**INTRODUCTION**

Sustaining the viability of stem cells is necessary before transplantation for use in several diseases, especially in cases involving degenerative tissues. This viability is what makes stem cells become adaptive and useful in achieving successful transplantation therapies.

The results of the study by Geng (2003) showed that the viability of mesenchymal stem cells (MSCs) injected in rats was very low, 99% of the injected MSCs were already undergoing apoptosis after day 4. This remarkably low viability may be associated with the damaged microenvironment of the tissue or organ,

failing to confer resilience to the stem cells. Increasing the viability, then, of transplanted stem cells is essential in improving the success rate in stem cell therapy.

The adaptability and viability of MSCs from bone marrow can be achieved by subjecting them to hypoxic preconditioning *in vitro* culture before transplantation (Safitri *et al.*, 2013; Safitri *et al.*, 2014a). Hypoxic preconditioning has proved that MSCs from bone marrow did not only confer viability and adaptability but also allowed stem cells to express quiescence *in vitro* as observed *in vivo*. Stem cell quiescence *in vivo* is known to inhabit the system long-term (Safitri *et al.*, 2014b).

The long-term maintenance of MSCs

**\*FOR CORRESPONDENCE:**

(email: rheru\_prasetyo@yahoo.co.id)

depends on the interaction with their optimal niches, especially specific microenvironments (Arai and Suda, 2008). The specific microenvironments with optimal niches is critical to ensure lifelong tissue maintenance and to protect the stem cell pool from senescent cells (premature exhaustion) (Tsai *et al.*, 2011), and apoptosis (Wang *et al.*, 2008) under various stresses.

This study was conducted to determine the viability of rabbit adipocyte stem cells (r-ASCs) subjected to hypoxic preconditioning *in vitro* with 3% oxygen concentration. This study serves as a new approach in sustaining viability in ASCs, based on the unaltered expression of CD90+, CD44+, and CD45- and quiescent cells expression with p63 as marker.

## MATERIALS AND METHODS

Animal studies were performed in accordance with the procedures approved by the Animal Care and Ethical Clearance Committee of the Faculty of Veterinary Medicine, Universitas Airlangga. Experiments also conformed with the National Research Council's guidelines (239-KE) through an ethical seminar. The research was conducted at an experimental laboratory within the Institute of Tropical Diseases and Veterinary Medicine Faculty, Universitas Airlangga.

### Isolation and culture of r-ASCs

Adipose tissue was first aspirated from the peritoneal region of one 6-month old male rabbit (New Zealand strain). Aspirate was stored and kept at 4°C and transported to the experimental laboratory at the Institute of Tropical Diseases, Universitas Airlangga for *in vitro* culture. Adipose tissue was first washed and separated from the mixture of stomach fluid, blood and fats, and further separated using a sterile separator funnel. Samples were washed with sterile saline solution and heated at 37°C repeatedly until clear. The funnel was reversed for 4-5 min then closed; its position was kept still for 3-5 min to allow for separation. For tissue digestion, the same volume as that of the sample was prepared, along with warm sterile saline

buffer containing 500 CDU/ml (equivalent to 0.5 Wunsch units/ml) of collagenase. Washed fat was poured from the separatory funnel into a sterile bottle which can hold four times the aspirate volume. Saline buffer or collagenase mixture was added, covered and placed on a warm shaker that was prewarmed at 35-38°C for 20±5 min. Frequency and amplitude of the shaking was set at a point that would allow mixing but prevent the separation of the floating adipose tissue from the collagenase liquid.

Tissue was then transferred into a sterile glass separatory funnel and allowed to settle for 5-10 min to begin phase separation. The next stage of the stopcock was opened, and the non-floating fraction, through a sterile 265 mm filter, was obtained in a sterile beaker. Aliquots of the non-floating solution were then collected in a beaker glass and placed in a 50 ml centrifuge tube and mixed at 400 g for 5 min at room temperature with low to medium speed. Supernatant aspirate (top layer) was slowly poured in a tube without pellets from the cell. Finally, the suspension was filtered in a 100 mm cell strainer and collected in a sterile tube (Rantam *et al.*, 2009).

### *In vitro* r-ASCs culture in hypoxic and hyperoxic preconditioning

Samples were centrifuged, then supernatant and cell suspension were aspirated and transferred into a 100 µl stromal inoculation of the cell medium placed in a plate. About 500 mg of adipose tissue were added with stromal medium until the container was full. Seventy-two hours after plating, aspirate was added in the medium. Next, the cell was washed with pre-warmed PBS (1% antibiotic added in solution), doing an up and down pipetting to gently clear the cells from tissue and blood cell fragments. Fresh stromal medium was added, just until well capacity of culture plate was reached. The subsequent medium was changed every 2-3 days until the cell has formed confluence of 80-90%, then the cells were harvested. This was done by removing the medium well first and storing it in a sterile tube under sterile media conditions to be used for subsequent cell culture applications. Next, 250-500 µl of cells



were added to the sterile warm PBS, letting the PBS be above the cell for 2 min. Furthermore, PBS was mixed with 500  $\mu$ l trypsin/EDTA solution (0.5%) and incubated for 5-10 min. At this point, observation under the microscope showed that 90% of the cells were removed. Five hundred  $\mu$ l stromal medium were then added to fill the serum in solution. This was used to neutralize trypsin reaction.

The medium which contains the cell suspension was transferred from the well into a sterile tube, centrifuged at 300 g for 5 min. Small amounts of aspirate of supernatant and cell suspension were mixed with stromal medium. Furthermore, a counting process was done using a cell dilution aliquot in trypan blue (for a 1:7 dilution; 12.5  $\mu$ l cell suspension was added for every 87.5  $\mu$ l trypan blue. Cells were counted using a hemocytometer. After this, cells were placed back in the appropriate culture plate cells (Rantam *et al.*, 2009). Passage was conducted thrice, then cells were subjected to two preconditioning treatments: (1) hypoxic chamber with only 3% O<sub>2</sub> placed in an incubator with 5% CO<sub>2</sub>; and (2) hyperoxic environment with 20% O<sub>2</sub> concentration.

#### Flow cytometry observation of CD90+ and CD44+ expression

Flow cytometry analysis was utilized to determine the expressions of CD90+ and CD44+. First, fat-free aspirate was centrifuged at 6000 rpm for 15 min at 4°C. The precipitate was mixed with cytoperm/cytofix two times the amount of cell number obtained. This mixture was centrifuged again and formed a supernatant and a pellet. BD wash was added to the pellet at four times the amount of cell number obtained from the first centrifugation. Mixture was centrifuged and added with lysis buffer at the amount twice that of the first obtained cell number. Subsequently, labeled antibody was added to each sample, arranging five tubes at once and processing in a similar manner. Wash tube was added with single staining with CD90 FITC and double staining with CD44 PE and CD45 PerCP. Finally, all samples were stored in 4°C in a darkroom and were analyzed with flow cytometry for 1 h (Macey, 2007).

#### Immunocytochemical analysis

Immunocytochemical (ICC) analysis was performed to determine the expression of p63 as marker of quiescent cells. Before the ICC methods were carried out, cytological preparation and further examination through immunocytochemical technique using monoclonal antibodies p63 was conducted. Observation on p63 expression was done using a light microscope. P63 expression is indicated by the number of cells with brownish chromogen discoloration (Kumar and Rudbeck, 2009).

#### Immunofluorescence analysis

Immunofluorescence analysis was performed to determine the expression of quiescent stem cells using p63 protein as marker (Safitri *et al.*, 2014b). After hypoxic preconditioning of r-ASCs, indirect immunofluorescence was done to detect p63 protein expression. The r-ASCs cell culture was harvested, placed in a 15 ml tube and fixed with methanol. After 15 min, each culture was coupled with a rabbit anti-p63 protein/P51A polyclonal antibody reagent, FITC conjugated primary antibodies (bs-0723R-FITC-Biossusa), were washed with PBS, then dropped on an object glass, and analyzed under a fluorescence microscope (Rantam *et al.*, 2014).

#### Statistical analysis

Expressions of CD90+ and CD44+ with flow cytometry and p63 with immunocytochemical method were statistically analyzed using SPSS 15 for Windows XP with the level of significance set at 0.01 and confidence level at 99%. Comparative hypothesis testing was done by testing data normality with Kolmogorov-Smirnov test, doing homogeneity of variance test, analysis of variance (ANOVA), and post-hoc test (least significant difference test) using Tukey's HSD at 5%.

Phenotype expression results were analyzed by immunofluorescence. Phenotype expressions analyzed were done on p63 expression as the marker for quiescence stem cells.

RESULTS AND DISCUSSION

The level of expressions of CD90+, CD44+, and CD45- in cells analyzed with flow cytometry showed that under hypoxic preconditioning in 3% O<sub>2</sub> concentration, r-ASCs culture were undifferentiated. Meanwhile, under 20% O<sub>2</sub> concentration, cells differentiated, as indicated

by the decreased expression of CD90+ and CD44+ (Fig. 1A-1C).

Based on Figure 1, the phenotype showed no significant differences between hypoxic treatments and control, suggesting that stem cells cultured in this study remained undifferentiated. Attaining undifferentiated cells was one of the main objectives of this

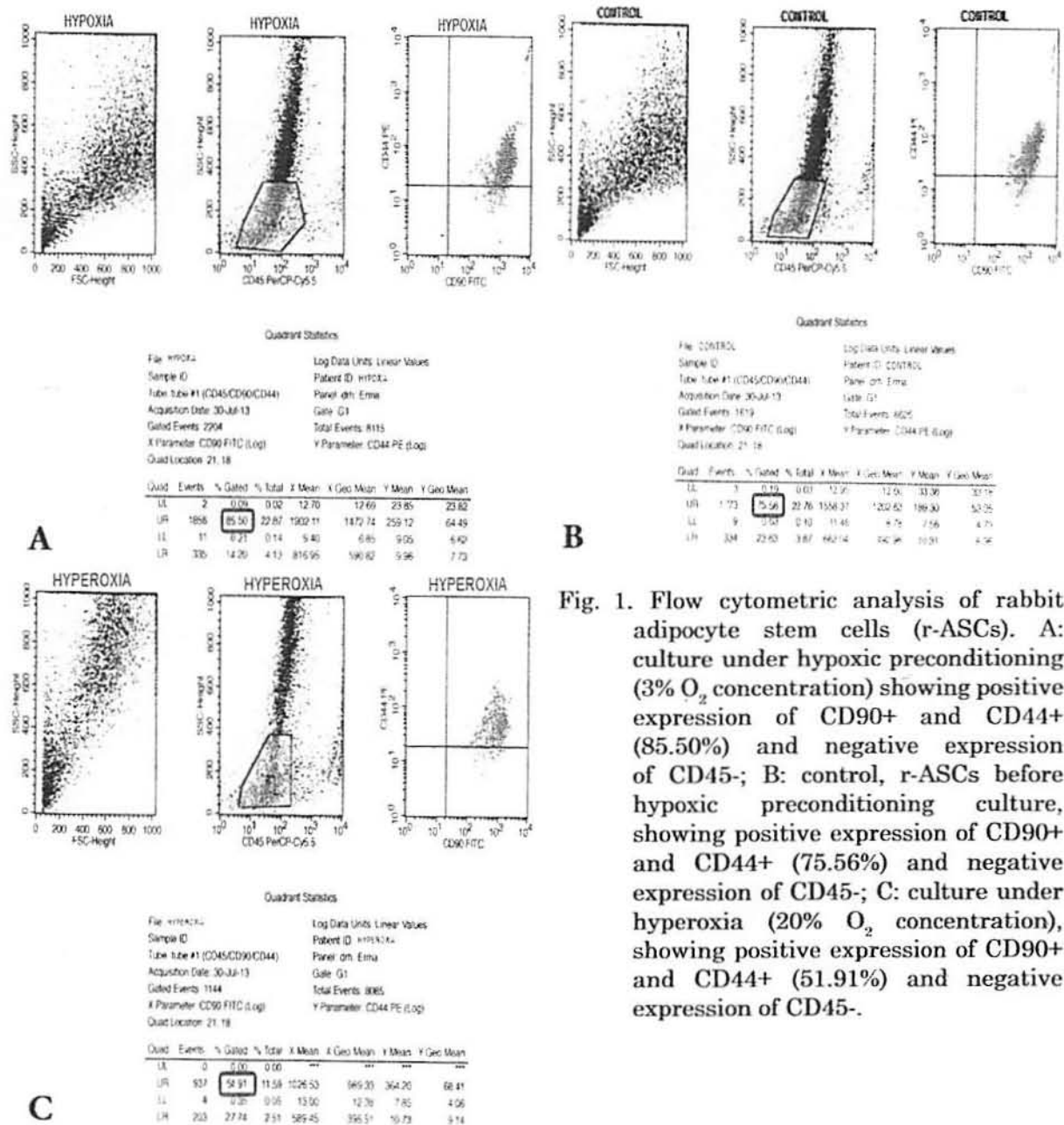

Fig. 1. Flow cytometric analysis of rabbit adipocyte stem cells (r-ASCs). A: culture under hypoxic preconditioning (3% O<sub>2</sub> concentration) showing positive expression of CD90+ and CD44+ (85.50%) and negative expression of CD45-; B: control, r-ASCs before hypoxic preconditioning culture, showing positive expression of CD90+ and CD44+ (75.56%) and negative expression of CD45-; C: culture under hyperoxia (20% O<sub>2</sub> concentration), showing positive expression of CD90+ and CD44+ (51.91%) and negative expression of CD45-.

study, since this is a key characteristic of long-term maintenance in stem cells. The results of this study is consistent with the report of Halim *et al.* (2010), which stated that undifferentiation is one of the unique characteristics of stem cells that sets it apart from other cells of the body.

The existence of this unique undifferentiated stem cells means that the *in vitro* cell culture in this study can survive much longer than the progenitor or the mature stem cells. This is based on the studies by Takubo (2012) and Elliason *et al.* (2010), where they emphasized that long-term maintenance (LTM) must be manifested by stem cell cultures to ensure the viability of transplanted stem cells. LTM, according to both researchers, can be attained when the stem cells are in the G0 phase when transplanted. G0 stage is the stage in which cultured cells are not bound to undergo the rest of the cell division (G1/S/G2/M) (Hermitte *et al.*, 2006; Arai and Suda, 2008). According to Morrison and Spradling (2008), Mohyeldin *et al.* (2010) and Suda *et al.* (2011), this stage is characterized by the presence of dormant or quiescent cells, and it is likely to occur if there is a conducive microenvironment for the stem cells.

The unique feature of stem cells is its ability to make it possible for any undifferentiated cell to become any kind of cell upon transplantation. This is the case of stem cells *in vivo*, such that, when under undifferentiated conditions, cells can differentiate into more than one cell type (multipotent/pluripotent). Thus, if undifferentiated cells' viability *in vitro* can be sustained, then cells that need to be transplanted can differentiate into any type of desired cell.

Immunocytochemical staining and immunofluorescence analysis enabled the expression of p63, the viability factor of mesenchymal stem cells. This positive expression was evident in r-ASCs cultured in hypoxic preconditioning at 3% O<sub>2</sub> concentration (Fig. 2A and 2B). Meanwhile, p63 expression was absent in cultured cells subjected to 20% O<sub>2</sub> concentration (Fig. 3A and 3B).

Hypoxic preconditioning at 3% O<sub>2</sub> concentration caused r-ASCs to remain undifferentiated and viable. This feature in

stem cells is important to ensure long-term tissue maintenance (Arai and Suda, 2008) and to protect the stem cell pool from premature exhaustion or turning into senescent cells (Tsai *et al.*, 2011) and undergoing apoptosis (Wang *et al.*, 2008). The lifelong maintenance of stem cells largely depends on the interaction with their specific microenvironment called niche (Arai and Suda, 2008).

In this study, hypoxic preconditioning with 3% O<sub>2</sub> concentration *in vitro* niche resembles the *in vivo* microenvironment. Specifically, under hypoxic preconditioning, inducible factor-1 $\alpha$  (HIF-1 $\alpha$ ), a transcription factor, is stabilized. This means that HIF-1 $\alpha$  levels are elevated in stem cells, which regulate their metabolism (Simsek *et al.*, 2010; Takubo *et al.*, 2010).

The one mechanism relating to the favorability of hypoxic conditions for stem cell maintenance is the oxygen-dependent hydroxylation of amino acids on specific a subunit of the hypoxia-inducible transcription factors (HIFs) (Watt *et al.*, 2009). The activity and stability of HIF-1 $\alpha$  protein subunits eventually allow their targeting for proteosomal degradation. In this study, as oxygen levels drop below 3%, hydroxylation becomes inhibited, stabilizing the HIF1 $\alpha$  subunits to bind with HIF1 $\beta$ , and then bind to hypoxia response element (HRE) in target genes, and, in association with transcriptional co-activators, turn these genes on.

Genes activated by HIFs include those encoding proteins involved in cell proliferation, self-renewal and survival. Self-renewal markers like SOX2 and OCT4 sustain undifferentiated state (Mohyeldin *et al.*, 2010).

Being undifferentiated is the basic characteristic of ASCs. In this study, undifferentiated state is indicated by the level of CD90+, CD44+, and CD45- expression in r-ASCs culture. Flow cytometric analysis of r-ASCs culture under hypoxic preconditioning with 3% O<sub>2</sub> concentrations showed positive expression of CD90+ and CD44+ (85.50%) (Fig. 1A), which was not significantly different ( $P > 0.05$ ) with the control (before hypoxic preconditioning). The control group showed positive expression of CD90+ and CD44+ (75.56%) (Fig. 1B). Meanwhile, under

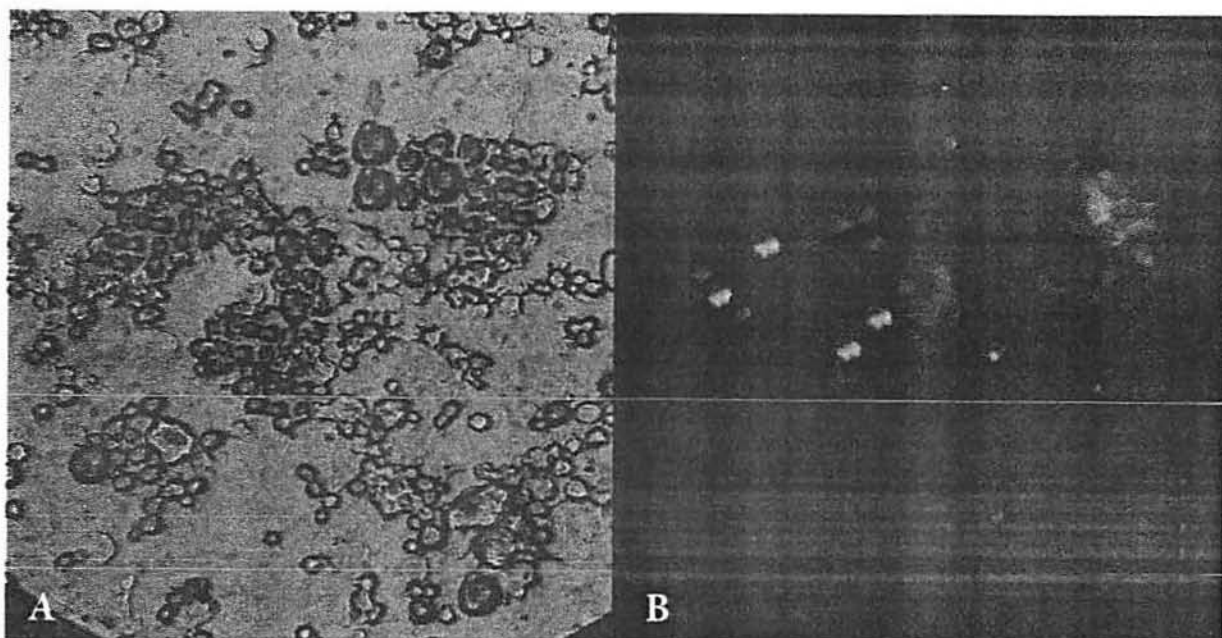

Fig. 2. Rabbit adipocyte stem cells (r-ASCs) cultured under hypoxic preconditioning (3% O<sub>2</sub> concentration). A: Immunocytochemical analysis: positive expression of p63 (red arrow head); B: Immunofluorescence analysis: positive expression of p63 (green fluorescence).

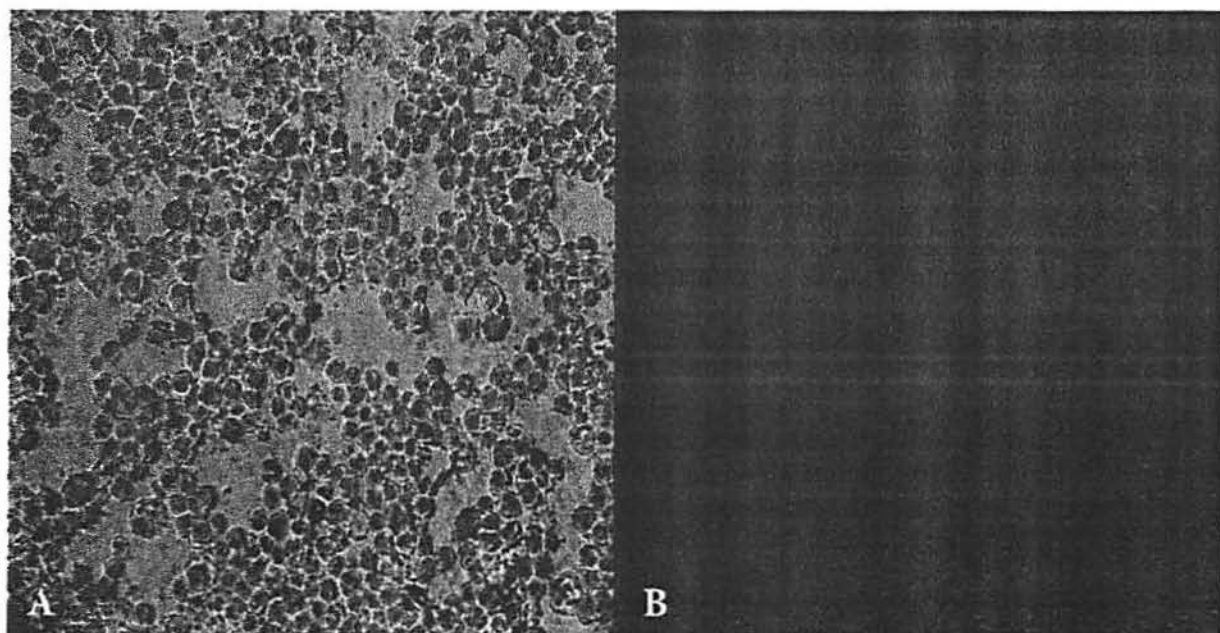

Fig. 3. Rabbit adipocyte stem cells (r-ASCs) cultured under hyperoxia (20% O<sub>2</sub> concentration). A: Immunocytochemical analysis: negative expression of p63 (red arrow head); B: Immunofluorescence analysis: negative expression of p63 (absence of green fluorescence).

hyperoxia (20% O<sub>2</sub> concentration), CD90+ and CD44+ expression was less pronounced (51.91%) (Fig. 1C).

This study shows that hypoxic preconditioning with 3% oxygen concentration enabled the maintenance of viability in r-ASCs before transplantation, as evident in the unaltered expressions of CD90+, CD44+, and CD45- and expression of quiescent cells with p63 as marker.

### ACKNOWLEDGMENT

This research was partially supported by the funding from the Directorate General of Higher Education (DIKTI) 2017, Ministry of National Education, Indonesia.

### REFERENCES

- Arai F and Suda T. 2008. *Quiescent Stem Cells in the Niche*. Stembook, ed. The Stem Cell Research Community, StemBook.
- Eliasson P, Rehn M, Hammar P, Larsson P, Sirenko O, Flippin LA, Cammenga J and Jonsson JI. 2010. Hypoxia mediates low cell-cycle activity and increases the proportion of long-term-reconstituting hematopoietic stem cells during *in vitro* culture. *Experimental Hematology* 38(4): 301-310.
- Geng YJ. 2003. Molecular mechanisms for cardiovascular stem cell apoptosis and growth in the hearts with atherosclerotic coronary disease and ischemic heart failure. *Annals of the New York Academy of Sciences* 1010(1): 687-697.
- Halim DH, Murty F, Sandra A, Boediono T, Djuwantono B and Setiawan B. 2010. *Stem Cell Basic Theory and Clinical Application*. Jakarta: Erlangga Press.
- Hermitte F, dela Grange PB, Belloc F, Praloran V and Ivanovic Z. 2006. Very low O<sub>2</sub> concentration (0.1%) favors G<sub>0</sub> return of dividing CD34+ cells. *Stem Cells* 24(1): 65-73.
- Kumar GL and Rudbeck L. 2009. *Immunohistochemical Staining Methods* (5<sup>th</sup> ed.). Carpinteria, CA: Dako North America.
- Macey MG (ed.). 2007. *Flow Cytometry: Principles and Applications* (3<sup>rd</sup> ed.). Jakarta: Humana Press.
- Mohyeldin A, Garzon-Muvdi T and Quiñones-Hinojosa A. 2010. Oxygen in stem cell biology: a critical component of the stem cell niche. *Cell Stem Cell* 7(2): 150-161.
- Morrison SJ and Spradling AC. 2008. Stem cells and niches: mechanisms that promote stem cell maintenance throughout life. *Cell* 132(4): 598-611.
- Rantam FA, Fezdiansyah N and Purwati A. 2009. *Stem Cell Exploration: Methods of Isolation and Culture* (1<sup>st</sup> ed.). Surabaya: Airlangga University Press.
- Rantam FA, Ferdiansyah X and Purwati X. 2014. *Mesenchymal and Hematopoietic Stem Cells Model Application* (2<sup>nd</sup> ed.). Surabaya: Airlangga University Press.
- Safitri E, Utama S, Bumi C, Mulyani SWM, Susilowati H, Retnowati E, Purwati, Prasetyo RH, Hariadi M and Rantam FA. 2013. The role of adaptive MSCs an attempt regeneration of spermatogenesis process using by hypoxia precondition *in vitro*. *Journal of Animal Production Advances* 3(11): 318-322.
- Safitri E, Utama S, Bumi C, Mulyani SWM, Retnowati E, Purwati, Prasetyo RH, Hariadi M, Aulani'am, Mahyudin F and Rantam FA. 2014a. Hypoxic preconditioning for viable and self renewing mesenchymal stem cells (MSCs) as the regeneration of spermatogenesis process. *Advances in Natural and Applied Sciences* 8(8): 42-46.
- Safitri E, Utama S, Prasetyo RH, Hariadi M and Rantam FA. 2014b. Quiescence stem cells (QSCs) for the treatment of infertility in male mice. *Asian Academy Research Journal of Multidisciplinary* 1(28): 187-199.
- Simsek T, Kocabas F, Zheng J, Deberardinis RJ, Mahmoud AI and Olson EN. 2010. The distinct metabolic profile of hematopoietic stem cells reflects their location in a hypoxic niche. *Cell Stem Cell* 7(3): 380-390.
- Suda T, Takubo K and Semenza GL. 2011. Metabolic regulation of hematopoietic stem cells in hypoxic niche. *Cell Stem Cell* 9(4): 298-310.
- Takubo K, Goda N, Yamada W, Iriuchishima H, Ikeda E and Kubota Y. 2010. Regulation of the HIF-1 $\alpha$  level is essential for hematopoietic stem cells. *Cell Stem Cell* 7(3): 391-402.
- Takubo K. 2012. The hypoxia regulatory system in hematopoietic stem cells. *Advances in Hematopoietic Stem Cell Research*.
- Tsai CC, Chen YJ, Yew TL, Chen LL, Wang JY, Chiu CH and Hung SC. 2011. Hypoxia inhibits senescence and maintains mesenchymal

- stem cell properties through downregulation of E2A-p21 by HIF-TWIST. *Blood Journal* 117(2): 459-469.
- Wang J, Chen TL, Jiang J, Shi H, Gui C, Luo RH, Xie XJ, Xiang MX and Zhang X. 2008. Hypoxic preconditioning attenuates hypoxia/reoxygenation-induced apoptosis in mesenchymal stem cells. *Acta Pharmacologica Sinica* 29(1): 74-82.
- Watt SM, Tsaknakis G, Forde SP and Carpenter L. 2009. Stem cells, hypoxia and hypoxia-inducible factors. In: Rajasekhar VK, Vemuri MC (eds.) *Regulatory Networks in Stem Cells. Stem Cell Biology and Regenerative Medicine*. Humana Press.



