



[Home](#) > [Journals](#) > [Optik](#) > [Editorial Board](#)

Optik

[Submit your Paper](#)[View Articles](#)

[➤ Guide for authors](#) [Track your paper](#) [▼](#) [➤ Order journal](#)

Editorial Board

40 editors and editorial board members in 19 countries/regions

CN China (9) DE Germany (5) US United States of America (5) JP Japan (3) ES Spain (3) IE Ireland (2)

FI Finland FR France IT Italy MY Malaysia MX Mexico PK Pakistan PL Poland QA Qatar

CH Switzerland TW Taiwan TH Thailand UA Ukraine GB United Kingdom

Editors-in-Chief



Prof. Dr. Jer-Shing Huang, PhD

 Leibniz Institute of Photonic Technology Research, Department of Nanooptics, Jena, Germany

 Spectroscopy, Microscopy, Physical Chemistry, Nanophotonics, Plasmonics, Analytical Chemistry, Photochemistry, Plasmonics, Nonlinear Nanooptics, Optical antennas, Metasurfaces, Chiral spectroscopy and imaging, Optical Trapping, Whispering-gallery Cavity, Optical Nanosensors

[> Contact Prof. Dr. Jer-Shing Huang, PhD](#)

Section Editors

Fibre Optics

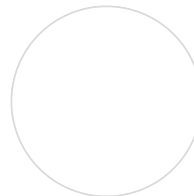

Hartmut Bartelt

 Leibniz Institute of Photonic Technology Fiber Optics Workgroup, Jena, Germany

[> Contact Hartmut Bartelt](#)

Nonlinear Dynamics in Optics and Photonics, Optical Solitons

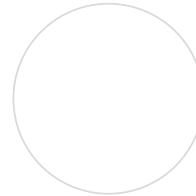

Anjan Biswas, Ph.D.

 Grambling State University, , United States of America

 Soliton perturbation; quasi-monochromatic solitons; quasi-particle theory; non-Kerr laws; conservation laws; differential group delay; DWDM systems., Optical Solitons

[> Contact Anjan Biswas, Ph.D.](#)

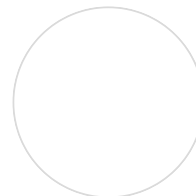

Chen-Bin Huang, PhD

 National Tsing Hua University, Hsinchu, Taiwan

 Optical solitons, nonlinear optics, fiber optics, ultrafast optics, nanophotonics, plasmonics, photonic quasiparticles, MMW photonics

[> View more](#) [> Contact Chen-Bin Huang, PhD](#)

Metamaterial Optics

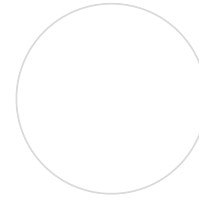

Pankaj Kumar Choudhury

 National University of Malaysia Institute of Microengineering and Nanoelectronics, Bangi, Malaysia

 Guided Wave Optics; Fiber Optics; Complex Optical Mediums; Metamaterials; Plasmonic Structures; Optical Sensors; Graphene Mediums; Photonic Crystals

[> Contact Pankaj Kumar Choudhury](#)

Thin Films and Plasmonics

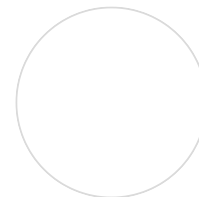

Muhammad Faryad

 Lahore University of Management Sciences, Department of Physics, Lahore, Pakistan

 Electromagnetic surface waves, Dyadic Green functions, Photonic Crystals, Optical Metamaterials

[> Contact Muhammad Faryad](#)

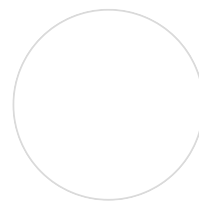

Mati Horprathum, PhD

 National Electronics and Computer Technology Center, Khlong Luang, Thailand

 Nanostructure plasmonic sensor, Optical thin film coating, Opto-chemical sensor, Glancing angle deposition technique, Optical and Photonic Materials

[> View more](#) [> Contact Mati Horprathum, PhD](#)

3D Display

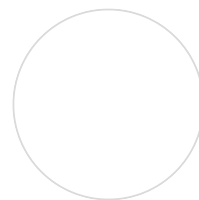

Dayan Li

 Shanghai Institute of Optics and Fine Mechanics Chinese Academy of Sciences, Jia Ding Qu, China

[> Contact Dayan Li](#)



Juan Liu

 Beijing Institute of Technology School of Optoelectronics, Hai Dian Qu, China

[> Contact Juan Liu](#)

Photovoltaic

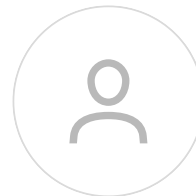

Waseem Haider

 Central Michigan University, Mount Pleasant, Michigan, United States of America

Nonlinear Optics and Matter Waves

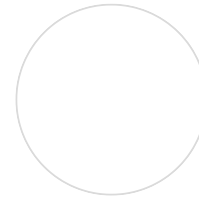

Qin Zhou

 Wuhan Textile University, , China

 Lasers and Quantum Optics

[> View more](#)

Ultrafast Optics, Photonic Materials and Nanostructures, Nanophotonics and related Applications

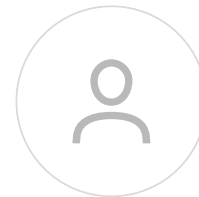

Luigi Sirleto

 Eduardo Caianiello Institute for Applied Science and Intelligent Systems National Research Council, Pozzuoli, Italy

📖 Nonlinear optics, Ultrafast optics, Nanophotonics, Photonic Materials and Nanostructures

Polymer and Glass Optical Material

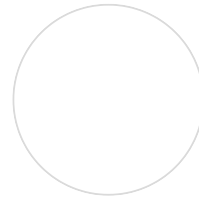

Hiroshi Yamagishi

🏛️ University of Tsukuba, Tsukuba, Japan

📖 Optics, Lasers, Supramolecular Chemistry, Organic Chemistry

Optical networks and communications

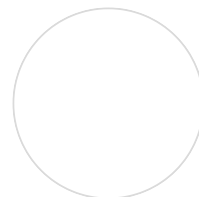

Mark Harrison

🏛️ Chapman University Fowler School of Engineering, Orange, United States of America



Nanophotonics, Plasmonics, Photonic integrated circuits, Nonlinear optics, Optical communications and information processing

[> View more](#) [> Contact Mark Harrison](#)

Optomechanics, Light-matter interaction, Metasurfaces, Near-field optics

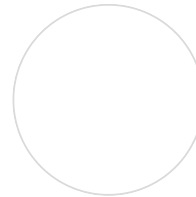

Angela Barreda, PhD

 University Carlos III of Madrid, Getafe, Spain

 Nanophotonics, Plasmonics, Dielectric Nanostructures, Optical Antennas, Metasurfaces, Sensing, Non-linear Nanooptics, Whispering-gallery modes

[> View more](#) [> Contact Angela Barreda, PhD](#)

Board

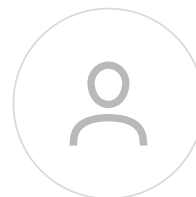

Dr. Milivoj Belic

 Texas A&M University at Qatar, Doha, Qatar



Prof. Dr. Eusebio Bernabeu

 Complutense University of Madrid, Faculty of Optics and Optometry, Madrid, Spain

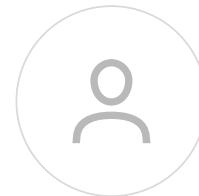

Professor Chaoqing Dai

 Zhejiang A and F University, Department of Optical Engineering, Lin'an, Zhejiang, China

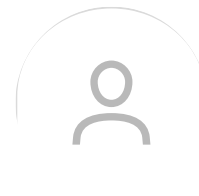

Professor Michael J. Damzen

 Imperial College London, Department of Physics, London, United Kingdom

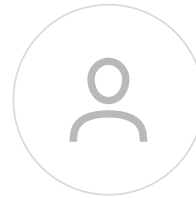

Prof. Dr. Francois Flory

 Fresnel Institute Marseille, Marseille, France

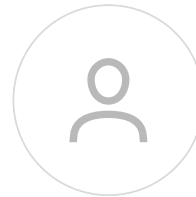

Dr. John Healy

 University College Dublin School of Electrical and Electronic Engineering, Dublin, Ireland





Prof. Dr. Henryk Kasprzak

 Wroclaw University of Technology, Faculty of Fundamental Problems of Technology, Wroclaw, Poland



Prof. Dr. Damien Peter Kelly

 Ilmenau University of Technology, Department of Mechanical Engineering, Ilmenau, Germany

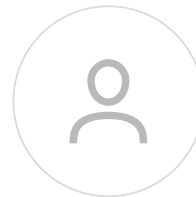

Professor Akhlesh Lakhtakia

 The Pennsylvania State University, Department of Engineering Science and Mechanics, University Park, Pennsylvania, United States of America



Professor Wenjun Liu

 Beijing University of Posts and Telecommunications School of Science, Beijing, China



Dr. Helena Lopez Aviles

 Coherent Inc, Santa Clara, California, United States of America

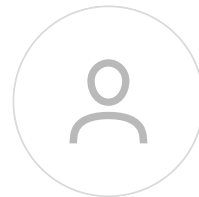

Prof. Dr. Baida Lü

 Sichuan University Institute of Laser Physics and Laser Chemistry, Chengdu, China



Prof. Dr. Kaoru Minoshima

 University of Electrocommunications, Faculty of Informatics and Engineering Graduate School of Informatics and Engineering, Chofu, Japan



Prof. Dr. Serguey Odoulov

 Institute of Physics National Academy of Sciences of Ukraine, Kyiv, Ukraine

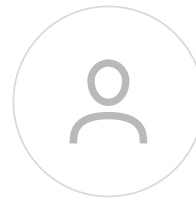

Professor Yukitoshi Otani

 Utsunomiya University Center for Optical Research and Education, Utsunomiya, Japan



Professor John Sheridan

 University College Dublin School of Electrical and Electronic Engineering, Dublin, Ireland

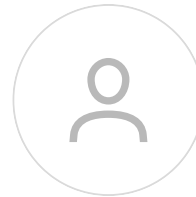

Dr. Serguej Stepanov

 Center for Scientific Research and Higher Education of Ensenada, Department of Optics,
Ensenada, Mexico

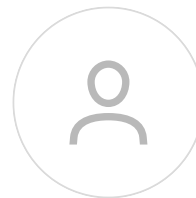

Prof. Dr. Jari Turunen

 University of Eastern Finland, Department of Physics and Mathematics, JOENSUU, Finland

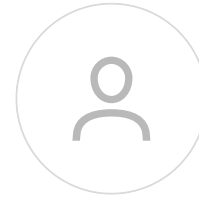

Dr. Lingli Wang

 Jos Schneider Optical Works GmbH, Bad Kreuznach, Germany

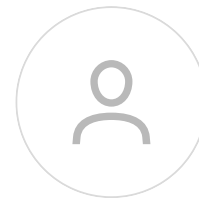

Professor Guo-Cheng Wu

 Neijiang Normal University, Neijiang, China

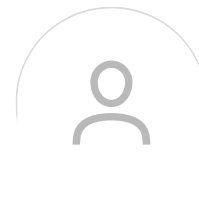

Prof. Dr. Chunming Zhang

 Xi'an Jiaotong University School of Science, Xian, China

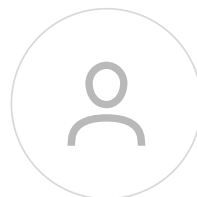

Prof. Dr. Xiao-Fei Zhang

 Shaanxi University of Science and Technology, Xi'an, China

All members of the Editorial Board have identified their affiliated institutions or organizations, along with the corresponding country or geographic region. Elsevier remains neutral with regard to any jurisdictional claims.

Optik

[Readers](#)

[View Articles](#)

[Volume/Issue Alert](#)

[Personalized
Recommendations](#)

[Authors >](#)

[Submit your Paper](#)

[Check Submitted Paper](#)

[Researcher Academy](#)

[Librarians >](#)

[Order Journal Institutional](#)

[Editors >](#)

[Publishing Ethics Resource Kit](#)

[Support Center](#)

[Rights and Permissions](#)

[Elsevier Author Services](#)

[Support Center](#)

[Track Accepted Paper](#)

[Reviewers >](#)

[Reviewer Recognition](#)

[Support Center](#)

[Societies >](#)

[German Society of Applied Optics](#)

[German Society of Electron Microscopy](#)

[optonet](#)

[European Optical Society](#)

Copyright © 2023 Elsevier, except certain content provided by third parties

Cookies are used by this site. [Cookie Settings](#)

[Terms and Conditions](#) [Privacy Policy](#) [Cookie Notice](#) [Sitemap](#)



Original research article

Detection of magnesium ion concentration using fiber coupler based displacement sensor with concave mirror target

M. Yasin^{a,*}, Samian^a, M. Khasanah^b^a Physics Department, Faculty of Science and Technology, Airlangga University, Surabaya 60115, Indonesia^b Chemistry Department, Faculty of Science and Technology, Airlangga University, Surabaya 60115, Indonesia

ARTICLE INFO

Article history:

Received 2 October 2017

Received in revised form 5 December 2017

Accepted 6 December 2017

Keywords:

Fiber coupler
 Displacement sensor
 Concave mirror
 Refraction

ABSTRACT

Detection of magnesium ion concentration was successfully demonstrated using a fiber coupler based displacement sensor probe in conjunction with a concave mirror target. Analysis of peak voltage result, which was obtained by moving a sensing port displacement from a fixed concave mirror (CM) was found to be useful to detect a magnesium ion concentration, which is filled in between the probe and target. The proposed sensor is capable for measuring magnesium ion with variation of concentration 0–5%. The resolution of the sensor can be achieved at 0.2%. It was also observed that the use of CM with a longer focal length improves the sensitivity of the sensor. The high sensitivity, the small size, the ease fabrication process, and the bio-compatibility of the proposed device are appealing characteristics that makes it ideal for practical bio-sensing applications.

© 2017 Elsevier GmbH. All rights reserved.

1. Introduction

Detections of refractive index and concentration of liquid solution have widely been reported using various fiber-optic sensors [1–5]. Owing to the intrinsic characteristics of the optical fiber, these sensors are in general simple to fabricate, compact, robust, immune to electromagnetic radiation, chemical and biological inert, and can be integrated in complex networks for real-time multiple parameter sensing. In recent years, many important advances were achieved in the fiber optic sensor technology; in terms of sensitivity, resolution, dynamic range, response time, signal to noise ratio and fabrication techniques. These advances have also promoted the development of optical fiber chemical sensors and biosensors [1,2]. For instance, the side-emitting technique was conducted using fiber optic micro-bend [3] and tapered fiber [4] to detect refractive index of chlorinated water and concentration of uric acid, respectively. Optical fibers coated with silver thin layer [5] and nanocomposite of ZnO-polypyrrol [6] were also used to detect concentration of uric acid and manganese ion based on surface plasmon resonance (SPR). Coreless fiber [7] and thin core fiber [8] connected to single mode fiber were used to detect concentration of sucrose and refractive index of solution, respectively.

A method based on displacement sensor can also be used to measure the concentration or refractive index of solution. For instance, a displacement sensor with a bundled fiber probe was capable of measuring refractive of solution [9], glucose concentration [10], calcium [11] and salinity [12]. This type of sensor works based on detection the output voltage as the displacement between sensor probe and mirror immersed in liquid of the solution sample is varied. Fiber coupler is an

* Corresponding author.

E-mail address: yasin@fst.unair.ac.id (M. Yasin).

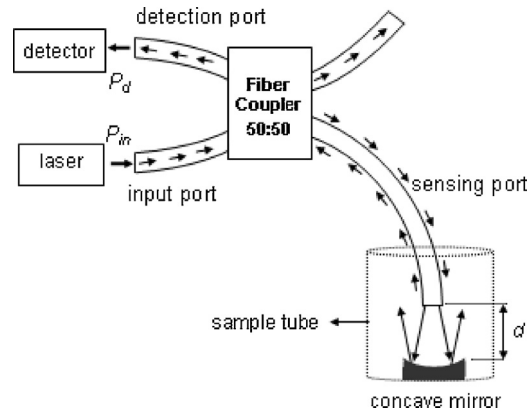

Fig. 1. Design of magnesium ion sensor using fiber coupler with concave mirror as reflector.

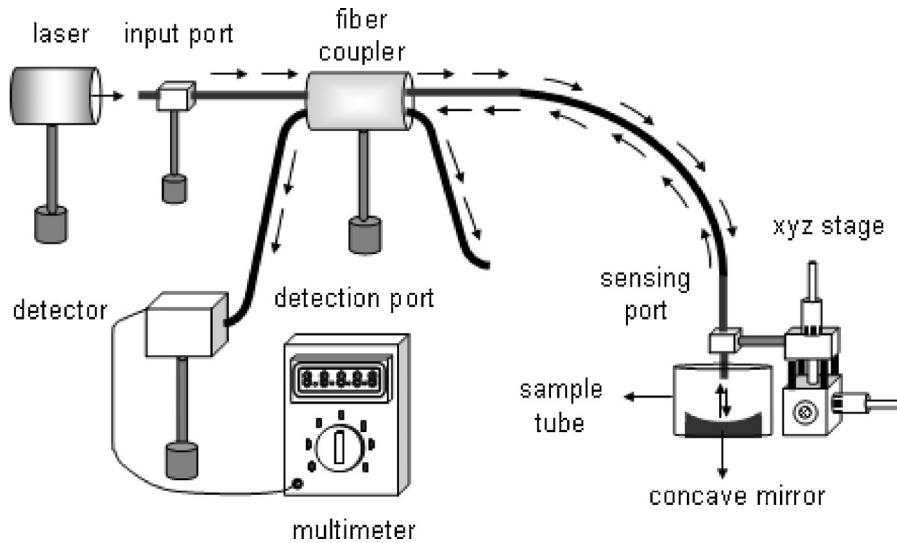

Fig. 2. Experimental setup for magnesium ion concentration sensor.

optical device that can be used to split a beam of light. It was used as a displacement sensor using a mirror as a target [13]. Based on the displacement sensor, fiber coupler was also employed as a level sensor [14] and a Rhodamine B concentration sensor [15] using a concave mirror (CM) as a target in conjunction with a green light source.

In this paper, we propose a new displacement sensor for measuring magnesium ion concentration using a fiber coupler as a probe and a concave mirror as a target. The magnesium ions detection is explored in this study since the ion is very important for the human in energy metabolism process, protein synthesis, muscle contraction, fat breakdown, DNA stability, and cell growth. Lack of magnesium ions in the body will affect health even can cause disease and cancer [16]. Therefore, the magnesium ions sensing device is becoming important especially for the food and beverage industry in order to meet the needs of magnesium ions that are perceived by the body.

2. Working principle of the sensor

Mechanism of magnesium ion detection using fiber coupler and concave mirror (CM) is shown in Fig. 1. Light source of the laser is coupled to input port of the coupler, part of the output light beam from the sensing port (P_e) enter to concave mirror. Medium between sensor port and CM is the testing sample. Partial of the reflected light beam from CM passed through a sensing port (P_b) and then transmitted to the detection port (P_d). The distance between sensing port and CM is attributed by d . If position of sensing port is changed in relation to CM, then the detected optical power as function of d is given by [15];

$$P_d = P_0 \left(1 - \exp \left(- \frac{2(d-f)^2/f^2}{\left(\frac{d^2-2df}{(d-f)a} \tan \sin^{-1} \left(\frac{NA}{n} \right) + 1 \right)^2} \right) \right) \quad (1)$$

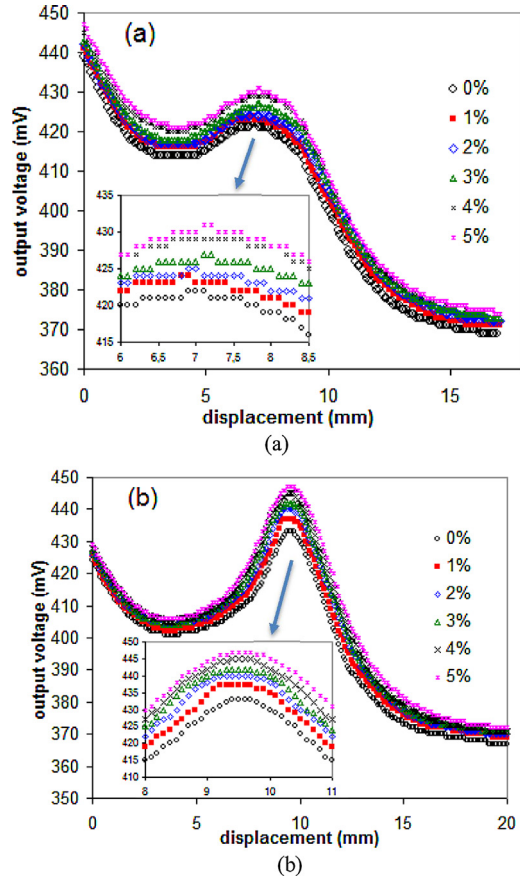

Fig. 3. Output voltage against the the displacement of sensing port as (a) CM 1 and (b) CM 2 was used as a target.

where a , NA , f and n is core of radius, numerical aperture, focal length of CM and refractive index of medium between sensing port and CM, respectively. P_0 can be written by equation as follows;

$$P_0 = 1.15cr(1 - cr) \left(10^{-0.1L_e} - 2 \times 10^{-0.1D} \right)^2 P_{in}, \quad (2)$$

where cr , L_e , and D are coupling ratio, excess loss, and directivity of fiber coupler respectively. While P_{in} optical power of the laser which is coupled to input port [13].

Optical power of laser is measured by an optical detector using digital voltmeter in term of output voltage (P_d). Output power is proportional to output voltage. When Eq. (1) is simulated, we can obtain the curve showing the relationship between output voltage (V) and d . The curve also indicates a peak voltage at a certain location. The value of V_p increase with refractive index of medium. If we assumed that refractive index is a linear function to magnesium ion concentration in solution as a medium, then the test sample of magnesium ion concentration can be read from the peak voltage. Variation of position scanning between sensing port and concave mirror is used to obtained peak voltage.

3. Experimental Setup

The schematic experimental setup for the proposed magnesium ion concentration sensor is shown in Fig. 2. It consists of a He-Ne laser (with wavelength of 632.8 nm and maximum power of 10 mW), fiber coupler and silicon detector. The fiber coupler probe was constructed from a multimode plastic fiber with structure 2×2 , diameter of 1 mm, 50/50 splitting ratio, 4 dB insertion loss and 1.6 dB excess loss. A CM with two different focal length 4.5 and 6 mm was used as reflector. CM was placed on the bottom sample tube with diameter of 4 cm and 3 cm height.

The positioning of the fiber coupler sensing port was accomplished by mounting it on a micro-displacement meter, which was rigidly attached to a vibration free table. Light from the fiber coupler input port was coupled into the sensing port. The signal from sensing port was measured by moving the probe away from the zero point, where the reflective surface of concave mirror and the probe were in close contact. The signal from the optical detector was converted into voltage and was measured by a digital voltmeter. The output intensity was measured by changing the position of the fiber coupler sensing port, which functions as probe from 0 to 15 mm in step of 100 μ m. The measurements were carried out for magnesium

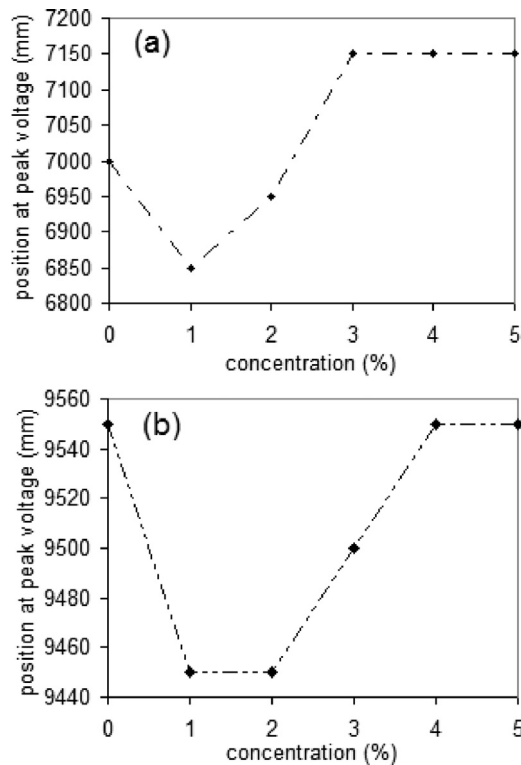

Fig. 4. Position at peak voltage versus magnesium ion concentration for (a) CM 1 and (b) CM 2.

ion with concentrations of 1, 2, 3, 4 and 5%. During the experiment, temperature was kept constant to that error due to temperature fluctuation is negligible.

4. Result and Discussion

Detection of magnesium ion concentration was obtained by monitoring the output voltage while the displacement between the sensing port and CM is varied. The initial position of the sensing port is about 2 mm above the center of the CM. The curves related to the output voltage as function of displacement sensing port was measured for two different CMs for comparison purpose. The results are analyzed and plotted as shown in Fig. 3. Figs. 3(a) and (b) shows the displacement curves with CM1 and CM2, which has a focal length 6 and 12 mm, respectively. The measurement error for both curves is obtained at around 0.6 mV. It is shown that the peak voltage position was obtained at around 7.0 mm and 9.5 mm for the displacement curves with CM1 and CM2, respectively. It is worthy to note that CM 1 and CM 2 has a diameter of 9.0 mm and 12.0 mm, respectively. In the experiment, the starting position of sensing port was at 2.0 m from surface of concave mirror. Compare to reference of 12, the main novelty of the proposed setup is applying fiber coupler probe as element sensing. In this probe, we have a first peak voltage at very close distance, therefore the sensor is suitable for a shorter distance measurement.

Figs. 4(a) and (b) show the peak voltage position at various magnesium ion concentrations for CM1 and CM2 target respectively. It is shown from both figures that peak voltage position changes irregularly with the variation of magnesium ion concentration. Therefore, it is difficult to predict magnesium ion concentration using the peak voltage position.

Correlation between peak voltage value and magnesium ion concentration is shown in Fig. 5. It indicates a linear trend relation between the peak voltage and magnesium ion concentration. The linearity is more than 99%. Therefore, we can determine value of concentration based on value of peak voltage. Slope of the curve in Fig. 5 defines sensitivity of the sensor, which indicates CM2 produces a better sensitivity than that of CM1. This is attributed to the longer focal length that allows the sensing fiber port to collect more light and increases the sensitivity. The refractive index of various magnesium ion concentrations was also measured using Abbe refractometer and the result is summarized in Fig. 6. The result shows that the refractive index is linearly correlated with the concentration. Therefore, this approach can be used for detection of magnesium ion concentration.

The stability of the sensor was then tested for 720 s for each interval 30 s and the result is presented in Fig. 7. Fig. 7 shows the sensor has a high stability with standard of deviation is 0.4 mV (0.1%) and 0.5 mV (0.11%) for CM 1 and CM 2, respectively. Resolution of the sensor is defined by ratio of standard deviation over sensitivity (slope of the linear curve). Overall, performance of the proposed magnesium ion concentration sensor using fiber cou-

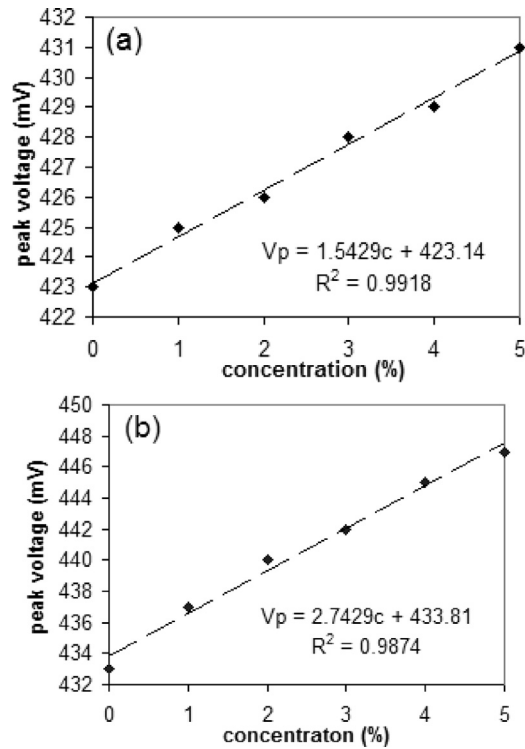

Fig. 5. Peak voltage as a function of magnesium ion concentration for (a) CM 1 and (b) CM 2.

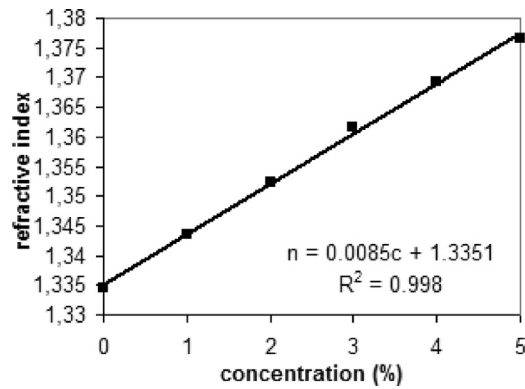

Fig. 6. Result of refractive index measurement versus a magnesium ion concentration.

Table 1

Performance of the sensor for magnesium ion detection with CM 1 and CM 2.

Parameters	Value	
	CM 1	CM 2
Sensor range (%)	0 – 5	0 – 5
Linear region (%)	0 – 5	0 – 5
Sensitivity (mV/%)	1.54	2.75
Resolution (%)	0.3	0.2

pler probe for CM 1 and CM 2 is summarized in Table 1. Table 1 shows that sensitivity of the sensor with CM 1 is higher than sensor with CM 2, therefore the sensor resolution with CM 2 is lower than CM 1 (1/1.5 times). The results indicate that fiber coupler based displacement sensor can be used for detection of magnesium ion concentration. During the experiment, the error due to this temperature variation is negligible as the temperature is kept constant at 25°C.

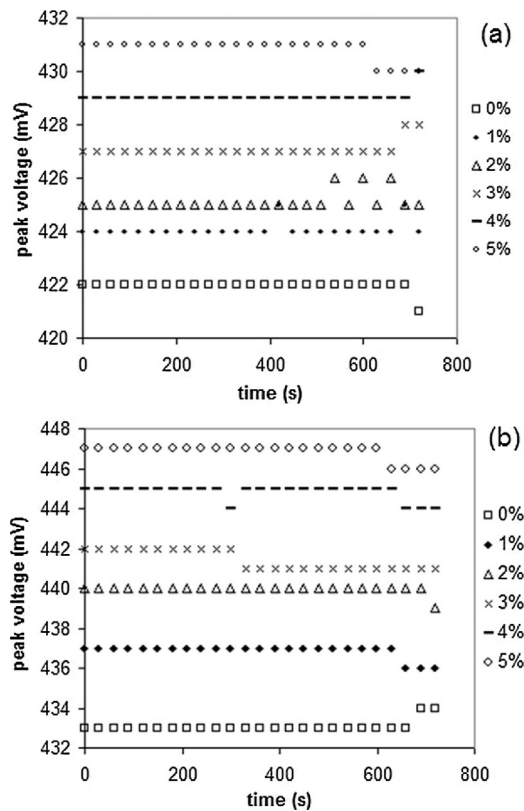

Fig. 7. Stability of the sensor for (a) CM 1 and (b) CM 2.

Based on a simple calculation, a response time or bandwidth of optical detector is used in this experiment can be found at 0.175 kHz.

5. Conclusion

Fiber optic coupler based displacement sensor configured with CM was proposed and demonstrated for detection of magnesium ion concentration. The results shows that a peak voltage of the sensor is linear to the concentration with the best resolution is obtained at 0.2% and range of 0–5%. The use of CM with a longer focal length improves the sensitivity of the sensor. The simplicity and low cost of the sensor make it suitable for various industrial applications.

Acknowledgement

This work was supported by the Airlangga University through “Mandat Grant” No: 569/UN3/2017.

References

- [1] Xu-dong Wang, Otto S. Wolfbeis, Fiber-optic chemical sensors and biosensors (2013–2015), *Anal. Chem.* 88 (2016) 203–227.
- [2] Christophe Caucheteur, Tuan Guo, Jacques Albert, Review of Plasmonic Fiber optic biochemical sensors: improving the limit of detection, *Anal. Bioanal. Chem.* 407 (2015) 3883–3897.
- [3] NibuA. George, AnuMaria Paul, M.S. Saranya, Microbend Fiber optic detection of continuously varying refractive index of chlorinated water, *Optik* 125 (2014) 301–303.
- [4] H.R.A. Rahim, N. Irawati, H.A. Rafea, H. Ahmad, S.W. Harun, R.M. Nor, detection Of different concentrations Of uric acid using tapered silica optical sensor coated with zinc oxide (Zno), *Jurnal Teknologi* 74 (8) (2015) 55–58.
- [5] Ravi Kant, Rana Tabassum, BanshiD. Gupta, Fiber optic SPR based uric acid biosensor using uricase entrapped polyacrylamide gel, *IEEE* 28 (19) (2016) 2050–2053.
- [6] Rana Tabassum, BanshiD. Gupta, Fiber optic manganese ion using SPR nanocomposite of ZnO-polypyrrol, *Sens. Actuators B* 220 (2015) 903–909.
- [7] WuroodAbdulkhaleq Khaleel, AbdulHadiM. Al-Janabi, High-sensitivity sucrose erbium-doped fiber ring laser sensor, *Opt. Eng.* 56 (2) (2017) 026116.
- [8] Jiangtao Zhou, Yiping Wang, Changrui Liao, Sun Bing, Jun He, Guolu Yin, Shen Liu, Zhengyong Li, Guanjun Wang, Xiaoyong Zhong, Jing Zhao, Intensity modulated refractive index sensor based on optical fiberMichelson Interferometer, *Sens. Actuators B* 208 (2015) 315–319.
- [9] Gobi Govindan, Dillibabu Srinivasan Gokul Raj, Sastikumar, Measurement of refractive index of liquids using fiber optic displacement Sensors, *J. Am. Sci.* 5 (2) (2009) 13–17.
- [10] S. Binu, V.P. Mahadevan Pillai, V. Pradeepkumar, B.B. Padhy, C.S. Joseph, N. Chandrasekaran, Fibre optic glucose sensor, *Mater. Sci. Eng. C* 29 (2009) 183–186.

- [11] M. Yasin, S. Soelistiono, Y.G. Yhun Yhuwana, M. Khasanah, H. Arof, N. Irawati, S.W. Harun, Intensity based optical fiber sensors for calcium detection, *J. Optoelectron. Adv. Mater.* 9 (9–10) (2015) 1185–1189.
- [12] HusnaAbdul Rahman, SulaimanWadi Harun, M. Yasin, Harith Ahmad, fiber-optic salinity sensor using fiber-optic displacement measurement with flat and concave mirror, *IEEE J. Sel. Top. Quant. Electron.* 18 (5) (2012) 1529–1533.
- [13] Samian, Y.H. Pramono, A.Y. Rohedi, F. Rusydi, A.H. Zaidan, Theoretical and experimental study of fiber-optic displacement sensor using multimode fiber coupler, *J. Optoelectron. Adv. Mater. Rapid Commun.* 3 (5) (2009) 411–414.
- [14] Samian, G.Y.Y. Yhosep, A.H. Zaidan, Herlik Wibowo, Gasoline level sensor based on displacement sensor using fiber coupler, *Measurement* 58 (2014) 342–348.
- [15] Samian, A.H. Zaidan, Moh. Yasin, Detection of Rhodamine B levels in distilled water based on displacement sensor using fiber coupler and concave mirror, *J. Optoelectron. Adv. Mater.* 18 (11–12) (2016) 988–992.
- [16] K.P. Schlingmann, M. Konrad, H.W. Seyberth, Genetics of hereditary disorders of magnesium Homeostatus, *Pediatr. Nephrol.* 19 (1) (2004) 13–15.



Complexity Open Access Journal

High Quality Open Access Original Research In Complexity. Publish Your Research With Us

Hindawi

Open

Optik

COUNTRY

Germany

Universities and research institutions in Germany

Media Ranking in Germany

SUBJECT AREA AND CATEGORY

Engineering
Electrical and Electronic Engineering

Materials Science
Electronic, Optical and Magnetic Materials

Physics and Astronomy
Atomic and Molecular Physics, and Optics

PUBLISHER

Urban und Fischer Verlag Jena

H-INDEX

79

Advances in Civi Eng. Papers

Open

PUBLICATION TYPE

Journals

ISSN

00304026, 16181336

COVERAGE

1946, 1968-1988, 1993-2021

INFORMATION

[Homepage](#)

[How to publish in this journal](#)

[Contact](#)



SCOPE

Optik publishes articles on all subjects related to light and electron optics and offers a survey on the state of research and technical development within the following fields: Optics - Optics design, geometrical and beam optics, wave optics- Optical and micro-optical components, diffractive optics, devices and systems- Photoelectric and optoelectronic devices-

Optical properties of materials, nonlinear optics, wave propagation and transmission in homogeneous and inhomogeneous materials- Information optics, image formation and processing, holographic techniques, microscopes and spectrometer techniques, and image analysis- Optical testing and measuring techniques- Optical communication and computing- Physiological optics- As well as other related topics.

 Join the conversation about this journal



Free expo pass

Asia Pacific Rail 2023 | 31 May 2023 - 1 June 2023

Asia Pacific Rail 2023



 Quartiles



FIND SIMILAR JOURNALS 

options 



Semua Kerusakan Ditanggung Asura
 ALL RISK dari ~~Rp3.050.000/tahun~~ **Rp1.982.500/t**
 Cuma di **lifepal** **CEK SEKARANG →**

1
Optical and Quantum Electronics
 USA
70%
 similarity

2
Journal of Optics (India)
 IND
62%
 similarity

3
Journal of Optoelectronics and Advanced Materials
 ROU
59%
 similarity

4
Optoelectronics and Advanced Materials, Rapid
 ROU
54%
 similarity

5
Opto-electronics Review
 NLD
47%
 similarity

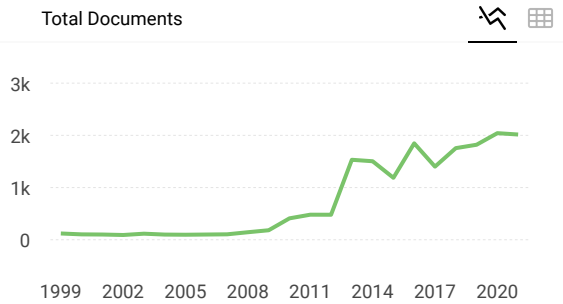
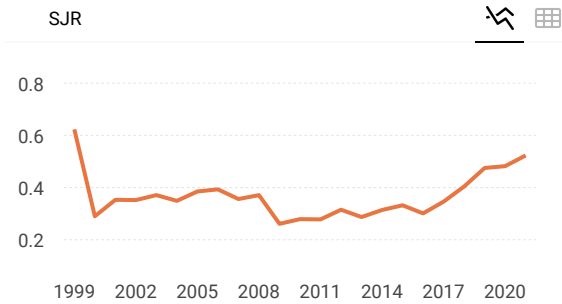

Citations per document

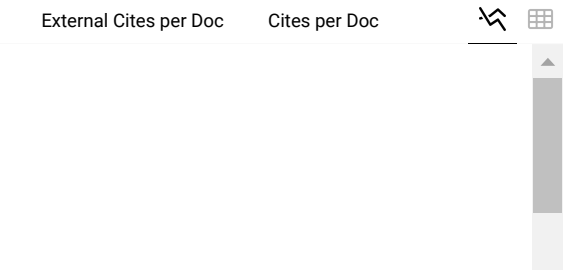
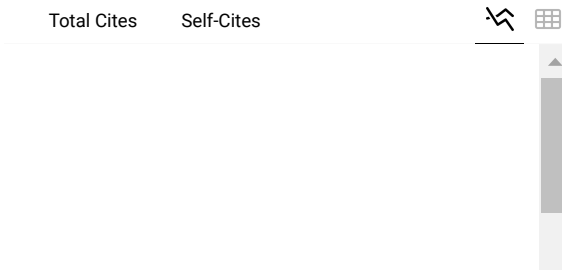

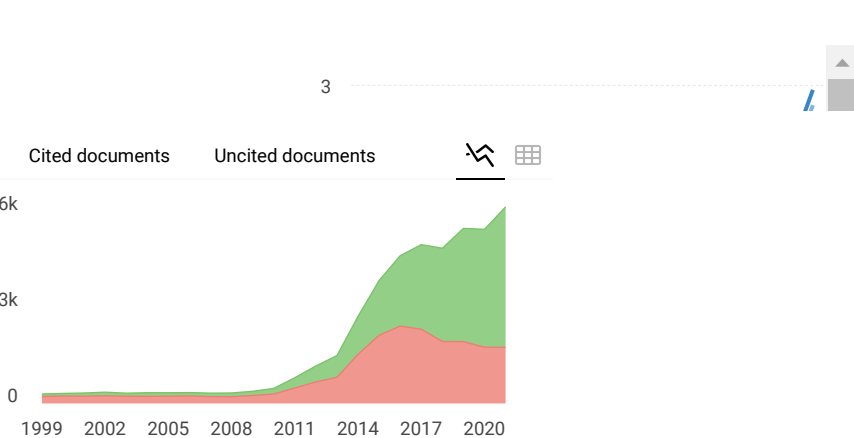
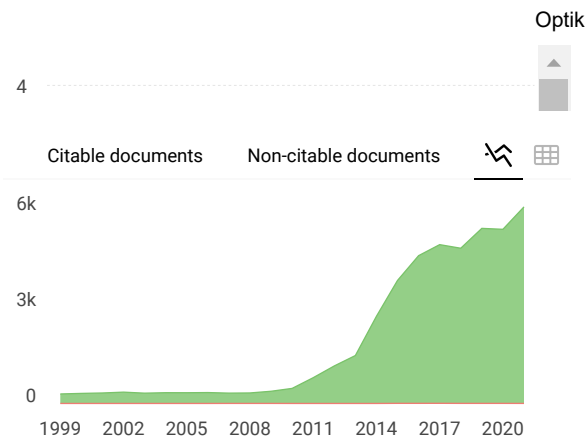
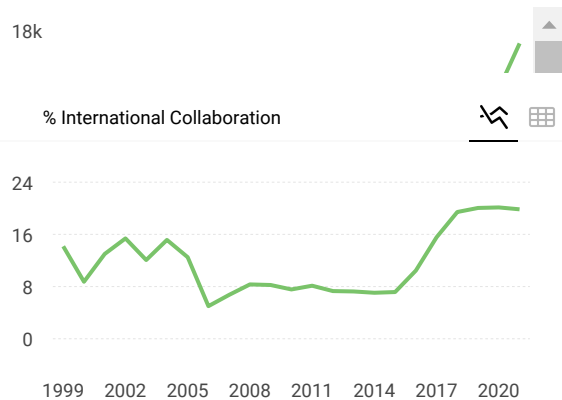

Optik

Q2 Atomic and Molecular Physics, and Optics
best quartile

SJR 2021
0.52

powered by scimagojr.com

← Show this widget in your own website

Just copy the code below and paste within your html code:

```
<a href="https://www.scima
```

SCImago Graphica

Explore, visually communicate and make sense of data with our **new data visualization tool.**

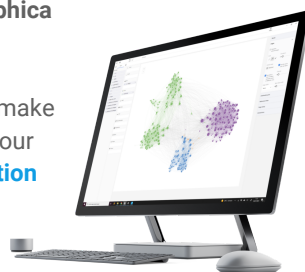

Strengthen Your Writing Tone

Ensure your message comes across as personable, constructive, and confident every time.

Grammarly

[Learn M](#)

Metrics based on Scopus® data as of April 2022

M **Mariam M Abud** 1 year ago

I want to Know the journal (optik) is classify within scopus
thank you

reply



Melanie Ortiz 1 year ago

SCImago Team

Dear Mariam,

Thank you very much for your comment.

All the metadata have been provided by Scopus /Elsevier in their last update sent to SCImago, including the Coverage's period data. The SJR for 2020 was released on 17 May 2021. We suggest you consult the Scopus database directly to see the current index status as SJR is a static image of Scopus, which is changing every day.

Best Regards, SCImago Team

Leave a comment

Name

Email

(will not be published)

Saya bukan robot reCAPTCHA
Privasi - Persyaratan

Submit

The users of Scimago Journal & Country Rank have the possibility to dialogue through comments linked to a specific journal. The purpose is to have a forum in which general doubts about the processes of publication in the journal, experiences and other issues derived from the publication of papers are resolved. For topics on particular articles, maintain the dialogue through the usual channels with your editor.

Developed by:



Powered by:



Follow us on @ScimagoJR

Scimago Lab, Copyright 2007-2022. Data Source: Scopus®

EST MODUS IN REBUS

Horatio (Satire 1,1,106)

[Cookie settings](#)

[Cookie policy](#)