

VOL. 2

NO. 9 - APRIL 2023

JRSSEM

Journal Research of Social Science,
Economics, and Management

E-ISSN: 2807-6311 | P-ISSN: 2807-6494

jrsem.publikasiindonesia.id



Focus and Scope

Journal Research of Social Science, Economics, and Management is a double-blind peer-reviewed academic journal and has open access to social science, economics, management, law, and education. The journal is published monthly once by CV. Publikasi Indonesia. Journal Research of Social Science, Economics, and Management provides a means for ongoing discussion of relevant issues that fall within the focus and scope of the journal that can be empirically examined. This journal publishes research articles covering social science, economics, management, law, and education.

Editorial Team

Chief Editor

Abdurokhim, Politeknik Siber, Cerdika, International, Indonesia [Scopus] [Scholar]

Journal Manager

Nayera Mohamed Shousha, (Cairo University, Mesir) [Scopus] [Scholar]

Editorial Board

Ashot Gevorgyan, Yerevan State University, Armenia [Scopus] [Scholar]

Bhavna Sharma, JIMS Engineering Management Technical Campus, India [Scopus] [Scholar]

Rene Faruk Garzozi-Pincay, Universidad Estatal Península de Santa Elena, Ecuador [Scopus] [Scholar]

Md. Isahaque Ali, Universiti Sains Malaysia, Malaysia [Scopus] [Scholar]

Mohd Norazmi Bin Nordin, Universiti Tun Hussein Onn, Malaysia [Scopus] [Scholar]

Johanuddin Lahap, Universitas Teknologi Mara, Malaysia [Scopus] [Scholar]

Dada Ab Rouf Bhat, University of Jammu, India [Scopus] [Scholar]

Fidya Arie Pratama, Institut Agama Islam Bunga Bangsa Cirebon, Indonesia [Scopus] [Scholar]

Riesti Triyanti, Research Center for Marine and Fisheries Socio Economics, Jakarta, Indonesia [Scopus]
[Scholar]

CREATIVE BEHAVIOR MEDIATES LEARNING ORIENTATION, KNOWLEDGE SHARING, MOTIVATION ON INSURANCE (STUDY ON 15 BIG INSURANCE COMPANIES IN INDONESIA)

Mochammad Isa Anshori^{1*}

Anis Eliana²

Falih Suaedi³

^{1,2,3}Universitas Airlangga

e-mail: isa.anshori@trunojoyo.ac.id¹, anis.eliyana.febunair@gmail.com², suaedifalih@gmail.com³

*Correspondence: isa.anshori@trunojoyo.ac.id

Submitted: 28 April 2022,

Revised: 07 May 2022,

Accepted: 18 May 2022

Abstract. The purpose of this research is to test and analyze the factors that affect the performance of insurance agents in this case insurance agents who are members of the Indonesian Life Insurance Association (AAJI) which are included in the 15 (fifteen) major insurance companies in Indonesia. This type of research is fundamental research or basic research, aiming to participate in the development of science. The method used is quantitative method with a total sample of 220 insurance agents. The analytical technique used in this research is SEM AMOS. The results showed that learning orientation had a significant effect on creative behavior, learning orientation had a significant effect on insurance agent performance, knowledge sharing had a significant effect on creative behavior, knowledge sharing had a significant effect on insurance agent performance, motivation had a significant effect on creative behavior, motivation had a significant effect on performance insurance agents, and creative behavior has a significant effect on the performance of insurance agents.

Keywords: creative behaviour; agency performance.

INTRODUCTION

The insurance industry, which is a member of the Indonesian Life Insurance Association (AAIJ), has developed various methods of digital-based financial services aimed at convenience, security, and customer convenience in transactions. However, these services still require regulatory policies from the Financial Services Authority (OJK).

OJK has been closely monitoring the development of digitalization in insurance transactions, including the trend of fintech. Until now, OJK still hints that applying digitalization rules in insurance will continue to refer to existing conventional rules. Until now, the e-policy has not yet been implemented.

Meanwhile, in the life insurance industry, the total premium income throughout 2020 was IDR 168.19 trillion compared to 2019's gain of IDR trillion. In line with that, the premium income of 15 life insurance companies with the largest premium income (life insurance market leaders) recorded a premium income growth of 4.06 percent to Rp. 139.79 trillion in 2020 compared to 2019's gain of Rp. 134.33 trillion. (business.com)

The performance of insurance agents has the most important role in an insurance business in running or marketing insurance products in the company concerned, not only marketing the product, but also providing education and building public awareness of the importance of insurance, including providing information or explain claim procedures. The agent's performance will have an impact on competitive advantage in the insurance business and

become the spearhead to achieve company goals ([Humaemah & Fauziah](#), 2020).

An insurance agent has good performance if they are able to get premiums as targeted by the company within a certain period. Meanwhile, indications of poor performance include low sales volume from premiums earned by agents so that they are not in line with company expectations ([Roussignol et al.](#), 2012). There are 5 aspects of performance, namely quality, quantity, timeliness, effectiveness and independence. employees who have high performance at work are in terms of quality, quantity, and effectiveness while employees who have low performance at work are in terms of punctuality and independence ([Venkatesan et al.](#), 2010).

The results of research conducted by the Insurance Media Research Institute (LRMA) 2019 on the insurance industry shows the life insurance performance as follows, LRMA shows, the achievement of the performance results of life insurance companies during 2019, the highest achievement in investment returns which shot up to 250 percent, from Rp. 8.75 trillion in 2018 to Rp30.62 trillion in 2019. The indicators for cash and banks grew by 41 percent from Rp11.46 trillion at the end of 2018, an increase of Rp16.19 trillion.

Several indicators that increased slightly, such as equity, rose 16.7 percent from Rp. 95.62 trillion in 2018 to Rp. 111.60 trillion at the end of 2019. Investment grew 8.8 percent, from Rp. 439.46 trillion in 2018 to Rp. 478.26 trillion. in the following year. Assets grew 9.6 percent, in 2018 it was at IDR 480.68trillion, increasing to IDR 526.63trillion in 2019. Likewise, premium

income rose only 4 percent from IDR167.97

trillion in 2018 growing to IDR 174.8 trillion in 2019.

LRMA noted that general insurance gross premiums grew 15.05 percent, from IDRtrillion as December 2018 to IDRtrillion as December 2019. Meanwhile, net premium growth was recorded at 15.78 percent, from IDR 32.58 trillion as of December 2018 to Rp37.72 trillion as of December 2019. This is the second year in a row that the results of the LRMA show that insurance premium growth has doubled digits.

As an illustration above, the performance of obtaining life insurance premiums from 2018 to 2019, has increased, given current trends and increasingly fierce competition, whether local insurance companies will be eliminated, of course, depends on how successful the company is in the midst of competition.

Based above that have been discussed in the previous section, the researchers are

interested in conducting research on the

performance of insurance agents through learning orientation variables, knowledge sharing, work motivation on the performance of insurance agents, through creative behavior as a mediating.

A. Variable

1. Human

Development of human resources in an organization is important. Investments in human resource development are expenditures aimed at improving the productive capacity of human beings. With good human resources, business organizations

will have competitive strength.

There are several definitions of human resource development as follows:

Human Resources Development (HRD) is a process to develop skills with a view to improving the performance of individuals, teams, work processes, and organizational work systems ([Dirani et al., 2020](#)).

Define human resource development as a series of systematic and planned activities designed by an organization to provide opportunities for its members to learn the skills needed to meet current and future job requirements ([McFadden, 2015](#)).

Human resource development is a planned and sustainable effort carried out by organizations in improving employee competence and organizational performance through training, education, and development programs ([Swart et al., 2012](#)).

2. View Theory (RBV)

Resources are defined as all assets, capabilities, organizational processes, company attributes, information, knowledge, and others that are controlled by the company and enable the company to understand and implement strategies that can improve the efficiency and effectiveness of the company ([Day, 2014](#)).

The resources in question can be tangible and intangible. Tangible resources are assets that can be seen and measured, such as

financial, organizational, physical and technological resources, while intangible resources are assets that are embedded in the history of the company and have accumulated over time, such as human resources, innovation and technology

reputation ([De Saa - Perez & Díaz](#)

[Díaz](#), 2010); ([Barney et al.](#), 2011); ([Glavas & Mathews](#), 2014).

3. Theory

Organizational Learning Theory

was popularized by ([Senge](#) 2017)

through his book about learning organizations entitled The Fifth Discipline. Senge's view states that humans can increase organizational capacity through a learning process. ([Hung et al.](#), 2010) states that the term organizational learning is often used interchangeably with the term organizational learning, because the two concepts have different meanings.

Organizational learning is a type of activity in an organization, namely an organization that learns; while learning organization is a form of organization ([Alerasoul et al.](#), 2021). The point is that an organization becomes a learning organization through the implementation of organizational learning ([Liao & Wu](#), 2010).v. However, the difference between organizational learning and organizational learning will be difficult to make.

4. Learning Orientation Learning

Attractiveness intrinsic at work, a preference for work challenges, an agent's view of becoming more understanding, or the search for opportunities that independently allow expertise to emerge ([McClver](#)

[et al.](#) 2013). In learning orientation,

it is also shown that there is a skill orientation ([Ames, Archer](#), 1998), salespeople (agents) enjoy an overview of the process how they

sell to be effective. They are

attracted by challenging sales situations and not by mistakes. The learning orientation of internationalized companies, including INVs, has been recognized as critical to their internationalization and their subsequent capability development and evolution ([Gerschewski, S., Lew,](#)

[YK, Khan, Z., & Park, BI](#) (2018))

5. (Knowledge Sharing).

The understanding of knowledge is widely associated with the terms data, information, intelligence, expertise, experience, ideas, intuition, or insight, all of which depend on the context in which the word knowledge is used. An important difference between information and knowledge is that information becomes knowledge when individuals read, understand, interpret, and apply information to certain job functions ([Marshall](#), 1997)

Nonaka (1994) provides some differences between knowledge and information, if information is a

flow of messages, whereas knowledge is created within the organization by the flow of information, which is based on the commitments and beliefs of its owners. One of the most obvious differences is the difference given by Alavi and Leider (2001), stating that information can be converted into knowledge when the information is processed or interpreted in the minds of individuals.

Knowledge sharing has become an integral part of the organization's business strategy, along with helping organizations to grow and innovate in the market, and gain a competitive Knowledge sharing has become an integral part of the organization's business strategy, along with helping organizations to grow and innovate in the market, and gain competitive advantage. Ganguly, A., Talukdar, A., & Chatterjee, D. (2019).

6. Work Motivation

Abraham Maslow (1943) suggests that basically all humans have basic needs. He shows it in 5 levels in the shape of a pyramid, people start pushing from the lowest level. These five levels of needs are known as Maslow's Hierarchy of Needs, ranging from basic biological needs to more complex psychological motives; which will only matter after basic needs are met. The needs at one level must be at least partially satisfied before the needs at the

next level become an important determinant of action.

Herzberg's (1966) two-factor theory separates satisfaction factors and dissatisfaction factors. The satisfaction factor (achievement; recognition; responsibility; progress; development) is obtained because the employee does the job, while the dissatisfaction factor (company policy and administration; supervision/supervision; working conditions; human relations; salary or income; status; job security; personal life) caused by environmental factors or work relations.

Intrinsic motivation is an act of maintaining and improving within the individual, while extrinsic is an active motivational act on the basis of external stimuli. (Sri, P udjjari, E. 2015).

7. Creative Behavior

The definition of creativity is divided into four dimensions; person, process, product and press, according to Taggar, (2004) in Meithiana, I. (2017) creativity as "the four p's of creativity", based on factor analysis Guilford found five traits that characterize the ability to think creatively, namely: fluency, flexibility, originality, elaboration, and reformulation. redefinition). In addition, the definition of creativity is also divided into consensual and conceptual definitions.

Martins & Martins (2002), Mokhber, M., Khairuzzaman, W., &

Vakilbashi, A. (2018) states that creativity and innovation have their own influence to change values, mindsets and behaviors that have previously been patterned which in turn will affect performance in its daily life. To create this new innovation requires the creativity of the organization or company itself. Wijaya, SV (2013) the results of his research stated that innovative nature can be seen from creativity agent in dealing with customers. there are four characteristics that stand out in insurance agents, namely the nature of flexibility in socializing, the nature of self-confidence, the nature of hard work, and the nature of self-control. In further research, researchers can adapt the items in the nine trait measurement tool due to the number of items per trait domain.

less balanced on favorable and unfavorable items. Virlia, S. (2017). it takes hard work and smart work by an insurance agent, to shape creative behavior. Hartono, R., & Anshori, MI (2019)

8. Insurance Agent Performance

In defining performance, experts use different terms. There are researchers who use the term competitive advantage, economic rent, and some use both. Barney (1991) defines competitive advantage as a unique product market strategy. Dessler (1992) defines performance as an employee's work performance, namely the comparison between actual work results and established work standards. Thus, performance focuses on the results of its work.

Research Model Development

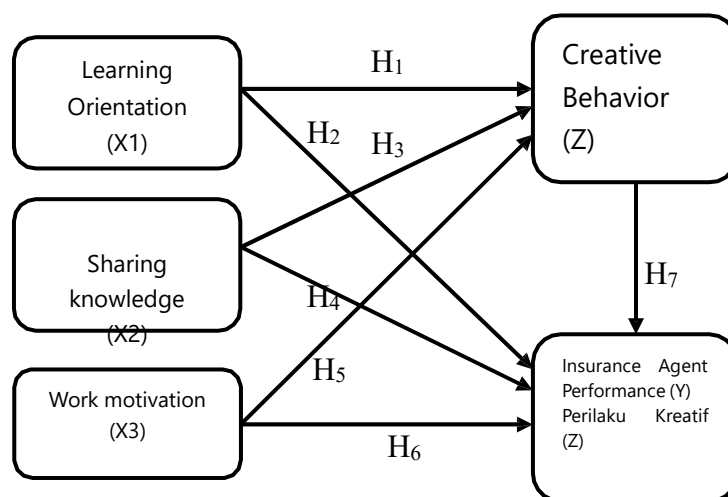

Figure 1. Model Development

METHODS

This research is included in exploratory research which aims to explore a phenomenon that is still new, and based on the time dimension is a cross sectional study, and based on data collection techniques, it is included in quantitative research with survey research. Based on data sourced from the Insurance, especially Surabaya in 2019, it was explained that the total number of permanent certified permanent agents was 882 permanent agents who were still declared uncertified, and were not included in the population of

this study because they were not said to be competent. The number of units of analysis in the research sample is determined by the rules that match the minimum number of samples according to the analytical tools used in the Structural Equation Model (SEM) of 100 to 200 or using the multiplication of the number of parameters times 5-10 sample units. The number of indicators in this study were 22 indicators multiplied by 10 parameters, so that a sample of 220 insurance agents was obtained. analysis technique uses the Structural Equation Model (SEM).

RESULTS AND DISCUSSION

A. Confirmatory Analysis of Exogenous Constructs I

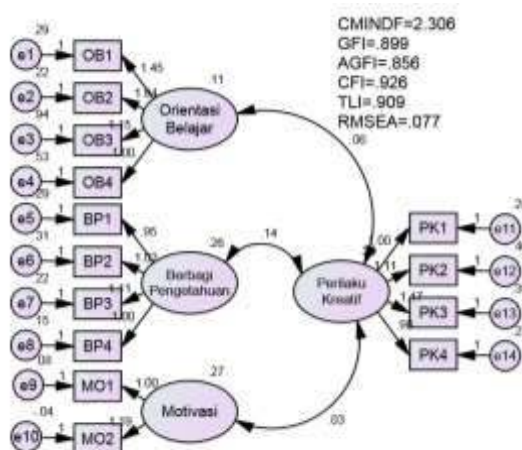

Figure 2. Exogenous Construct Analysis

Table 1. Analisis Variabel Eksogen

Indicators	Construction	Estimate	SE	CR	P	Label
OB4	Learning Orientation	1,000				
OB3	Learning Orientation	1,148	.300	part_1	***	3.834
OB2	Learning Orientation	1.936	.398	4.871	***	part_2
OB1	Learning Orientation	4.765	.304	par_3	***	1.448
BP4	Knowledge Sharing	1,000				
BP3	Knowledge Sharing	1109	.105	10,605	***	par 4

Indicators	Construction	Estimate	SE	CR	P	Label
BP2	Knowledge Sharing	1,019	***	107 9,491	par_5	BP1
Knowledge	Sharing	.950	MO1	par_6	***	9,283
.102	Motivation	1,000				
MO2	Motivation	1,185	.261	4,547	***	par_7
PK1	Creative Behavior	1,000				
PK2	Creative Behavior	1.108	.121	9,158	***	par 8
PK3	Creative Behavior	1.173	.129	9.106	***	par 9
PK4	Creative Behavior	.978 .107 9.096	***	par	10	In

The confirmatory analysis of the exogenous variables above it can be seen that the probability value of the CFA test results is 0.000. Seeing the small probability value that is smaller

than 0.05, it can be concluded that there are similarities in the value of the constructs used in the CFA.

1. Confirmatory Analysis of Endogenous I

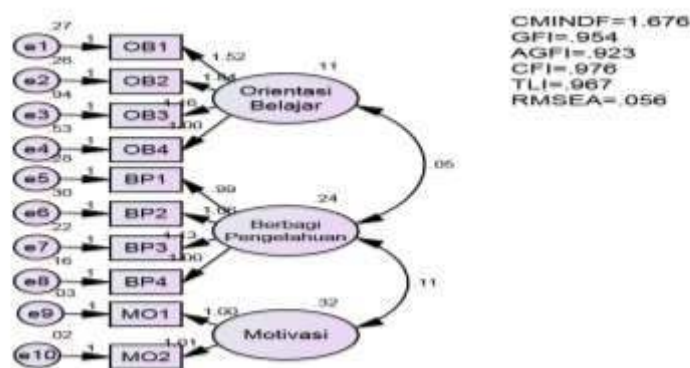

Figure 2. Endogenous I Confirmation Analysis

Table 2. Endogenous Analysis

Indicator	Construct	Estimate	SE	CR	P	Label
OB4	Learning Orientation	1,000				
OB3	Learning Orientation	1,159	.303	3,826	***	part_1
OB2	Learning Orientation	1,836	.376 4.881	***	part_2	OB1
Learning	Orientation	1,519	.336	4,515	***	par_3
BP4	Knowledge Sharing	1,000				
BP3	Knowledge Sharing	1,130	.107	10,571	***	par 4

Indicator	Construct	Estimate	SE	CR	P	Label
BP2	Knowledge Sharing	1,061	111 9,556	par_5	***	Knowledge
BP1	Sharing	9,322	.106	par_6	***	MO1
.988	Motivation	1,000				
MO2	Motivation	1,009	.071	14,114	***	par_7

In the confirmatory analysis of the endogenous variables above, it can be seen that the probability value of the CFA test results is 0.000. Seeing the small probability value that is smaller

than 0.05, it can be concluded that there are similarities in the construction values used in the CFA.

B. Confirmatory Analysis of Endogenous Constructs II

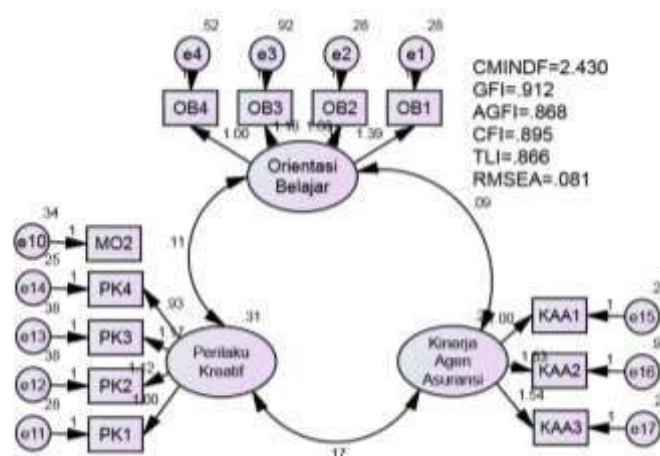

Figure 3. Confirmation of Endogenous Construct II

Table 3. Construction value in CFA

Indicator	Construct	Estimate	SE	CR	P	Label
OB4	Learning Orientation	1,000				
OB3	Learning Orientation	1,165	.279	4,174	***	part_1
OB2	Learning Orientation	1,685	.327	5145	OB1	part_2 ***
Learning	Orientation	1.393	.287	4.856	***	par_3
PK1	Creative Behavior	1,000				
PK2	Creative Behavior	1,121	.120	9,347	***	par 4
PK3	Creative Behavior	1,173	.128	9,156	***	par_5
PK4	Creative Behavior	.935	.103	9,032	***	par_6
KAA 1	Performance_Insurance Agent	1,000				

Indicator	Construct	Estimate	SE	CR	P	Label
KAA2	Performance_Insurance Agent	1,533	.233	6,577	***	par_7
KAA3	Performance_Agen Insurance	1,536	7,810	***	par_8	In

The confirmatory analysis of the endogenous variables above, it can be seen that the probability value of the CFA test results is 0.000. Seeing the small probability value that is smaller than 0.05, it can be concluded that there are similarities in the construction

values used in the CFA.

C. Model Structural (Structural Model)

In the structural model analysis of the overall model is carried out. The following shows the Goodness-of-fit from analysis model structural:

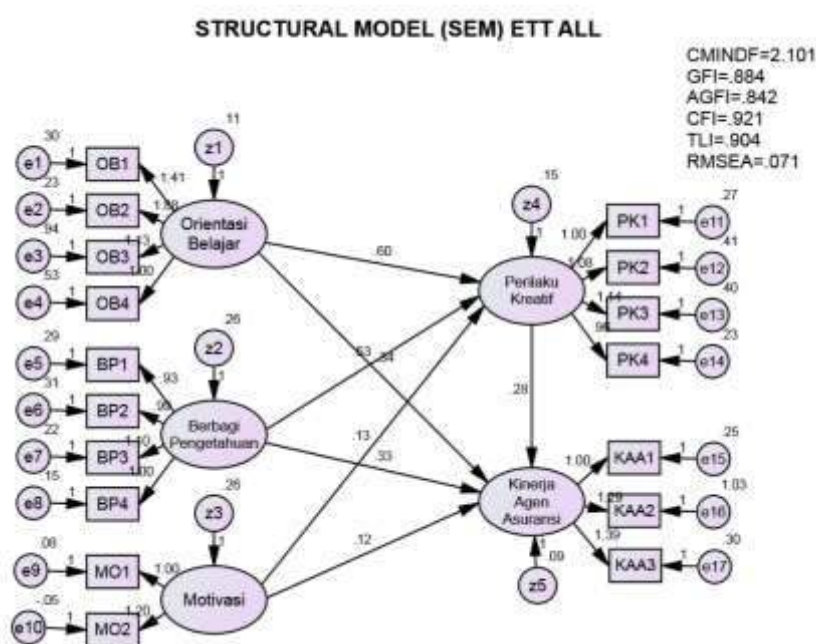

Figure 4. Structural Model (SEM) Ett All

Table 4. Overall Model Fit Test Results / Overall

No	Test	Criteria Match	Results	Description
1.	CMIN/DF	CMIN/DF 3	2.101	Good Fit
2.	RMSEA	RMSEA ≤ 0.08	0.071	Good Fit
3.	CFI	CFI 0.90	0.921	Good Fit
4.	GFI	GFI 0.90	0.884	Marginal Fit
5.	TLI	TLI 0.90	0.904	Good Fit

1645 | Creative Behavior Mediates Learning Orientation, Knowledge Sharing, Motivation on Insurance (Study on 15 Big Insurance Companies in Indonesia)

CMIN/DF or normed chi-square is an index used to develop and test whether a model fits the data, is sensitive to the number of samples. CMIN/DF shows a good level of model suitability if the value is 3. In this study, the CMIN/DF value was 2.101. These results indicate that the tested model has met the required criteria.

RMSEA is a measure of badness of fit that is used to compensate for the chi square statistic in a large sample. The smaller the RMSEA value, the better the suitability level and the acceptable RMSEA value is 0.08. This study has an RMSEA value of 0.071 (good fit).

CFI is a model feasibility test and is not sensitive to sample size and has a Cut of Index 0.90. Acceptable values are those between 0 and 1, the higher the value, the better fit. This study resulted in a CFI value of 0.21 and included in good fit.

GFI is a suitability index for calculating the weighted proportion of

variance in the sample covariance matrix described by the estimated population covariance matrix. According to (Hair et al., 2010), the closer the value to 1 or 0.90, the GFI value is considered to be better. Meanwhile, it can be said that the marginal value is if the GFI value is 0.8. In this study, the GFI value was 0.884 so that the GFI value was included in the marginal fit.

The TLI is a comparison of the chi-square for zero and the specified model, which to some degree takes into account the complexity of the model. The table above shows the value of 0.904 (good fit). The results of this value indicate that the model being tested has met the required criteria. Based on the description in the table, the structural model as a whole has met the required relative value of Goodness-of-fit so that the analysis is continued by testing the hypothesis.

Table 5. Hypothesis Testing Results

Interrelationship	Value	Estimate Ratio -			Information
		Critical	P	Value	
H1	Learning Orientation (OP) --> Creative Behavior (PK)	0,596	3,696	***	Significant
H2	Learning Orientation (OP) --> Insurance Agent Performance (KAA)	0.342	2,458	0.014	Significant
H3	Knowledge Sharing (BP) --> Creative Behavior (PK)	0.530	5,762	***	Significant
H4	Knowledge Sharing (BP) --> Insurance Agent Performance (KAA)	0.328	3,293	***	Significant
H5	Motivation (MO) --> Creative Behavior (PK)	0.130	1.975	0.048	Significant

Interrelationship	Value	Estimate Ratio -			Information
		Critical	P	Value	
H6	Motivation (MO) --> Insurance Agent	0.121	2,069	0.039	Significant
	Performance (KAA)				
H7	Creative Behavior (PK) --> Insurance Agent Performance (KAA)	0.281	2.781	0.005	Significant

Results The results showed that learning orientation had a significant effect on creative behavior, learning orientation had a significant effect on the performance of insurance agents, knowledge sharing had a significant effect on creative behavior, and knowledge sharing had a significant effect. if it affects the performance of insurance agents, motivation has a significant effect on creative behavior, motivation has a significant effect on the performance of insurance agents, and creative behavior has a significant effect on the performance of insurance agents.

CONCLUSIONS

Based on the results of research and analysis of the factors that affect the performance of insurance agents in this case insurance agents who are members of the Indonesian Life Insurance Association (AAJI) it is known that learning orientation has a significant effect on creative behavior, learning orientation has a significant effect on insurance agent performance, knowledge sharing a significant effect on creative behavior, knowledge sharing has a significant effect on the performance of insurance agents, motivation has a significant effect on creative behavior, motivation has a significant effect on the performance of insurance agents, and

creative behavior has a significant effect on the performance of insurance agents.

REFERENCES

- Alerasoul, S. A., Afeltra, G., Hakala, H., Minelli, E., & Strozzi, F. (2021). Organisational learning, learning organisation, and learning orientation: An integrative review and framework. *Human Resource Management Review*, 2(3), 100–114. <https://doi.org/10.1016/j.hrmr.2021.100854>
- Barney, J. B., Ketchen Jr, D. J., & Wright, M. (2011). The future of resource-based theory: revitalization or decline? *Journal of Management*, 3(5), 1299–1315. <https://doi.org/10.1177/0149206310391805>
- Day, G. S. (2014). An outside-in approach to resource-based theories. *Journal of the Academy of Marketing Science*, 4(2), 27–28. <https://doi.org/10.1007/s11747-013-0348-3>
- De Saa-Perez, P., & Díaz-Díaz, N. L. (2010). Human resource management and innovation in the Canary Islands: an ultra-peripheral region of the European Union. *The International Journal of Human Resource Management*, 2(10), 1649–1666. <https://doi.org/10.1080/09585192.2010.500488>

- Dirani, K. M., Abadi, M., Alizadeh, A., Barhate, B., Garza, R. C., Gunasekara, N., Ibrahim, G., & Majzun, Z. (2020). Leadership competencies and the essential role of human resource development in times of crisis: a response to Covid-19 pandemic. *Human Resource Development International*, 2(4), 380–394. <https://doi.org/10.1080/13678868.2020.1780078>
- Glavas, C., & Mathews, S. (2014). How international entrepreneurship characteristics influence Internet capabilities for the international business processes of the firm. *International Business Review*, 2(3), 228–245. <https://doi.org/10.1016/j.ibusrev.2013.04.001>
- Hair, J. F., Black, W. C., Babin, B. J., Anderson, R. E., & Tatham, R. L. (2010). Multivariate data analysis: A global perspective (6th Editio). In *Upper Saddle Rider: Pearson Education*.
- Humaemah, R., & Fauziah, S. (2020). Analisis Peran Kinerja Agen Asuransi Dalam Membantu Penyelesaian Klaim Pada Produk Siagakoe. *Syar'Insurance: Jurnal Asuransi Syariah*, 6(2), 84–104. <http://dx.doi.org/10.32678/sijas.v6i2.3161>
- Hung, R. Y. Y., Yang, B., Lien, B. Y.-H., McLean, G. N., & Kuo, Y.-M. (2010). Dynamic capability: Impact of process alignment and organizational learning culture on performance. *Journal of World Business*, 4(3), 285–294. <https://doi.org/10.1016/j.jwb.2009.09.003>
- Liao, S.-H., & Wu, C. (2010). System perspective of knowledge management, organizational learning, and organizational innovation. *Expert Systems with Applications*, 3(2), 1096–1103. <https://doi.org/10.1016/j.eswa.2009.06.109>
- McFadden, C. (2015). Lesbian, gay, bisexual, and transgender careers and human resource development: A systematic literature review. *Human Resource Development Review*, 4(2), 125–162. <https://doi.org/10.1177/1534484314549456>
- McIver, D., Lengnick-Hall, C. A., Lengnick-Hall, M. L., & Ramachandran, I. (2013). Understanding work and knowledge management from a knowledge-in-practice perspective. *Academy of Management Review*, 3(4), 597–620. <https://doi.org/10.5465/amr.2011.0266>
- Roussignol, X., Currey, C., Duparc, F., & Dujardin, F. (2012). Indications and results for the Exogen™ ultrasound system in the management of non-union: a 59-case pilot study. *Orthopaedics & Traumatology: Surgery & Research*, 9(2), 206–213. <https://doi.org/10.1016/j.otsr.2011.10.011>
- Senge, P. M. (2017). The leaders new work: Building learning organizations. In *Leadership perspectives* (pp. 51–67). Routledge.
- Swart, J., Mann, C., Brown, S., & Price, A. (2012). *Human resource development*. Routledge.
- Venkatesan, S., Chellappan, C., & Dhavachelvan, P. (2010). Performance analysis of mobile agent failure recovery in e-service applications. *Computer Standards & Interfaces*, 3(2),
-
-

38–43.

<https://doi.org/10.1016/j.csi.2009.06.001>

1



© 2022 by the authors. Submitted for possible open access publication under the terms and conditions of the Creative Commons Attribution (CC BY SA) license (<https://creativecommons.org/licenses/by-sa/4.0/>).