

**The 6th ASEAN Regional Union Psychological Society
(ARUPS) Congress**
**“Driving Mental Revolution in the Psychological Century: Enhancing
Psychological Services for a Better Future”**
20 -22 February 2018, Bali-Indonesia

Proceeding



Editors:
Andik Matulesy
Tjipto Susana
Mirra Noor Milla
Anrilia Ema M. Ningdyah

Hosted by:
Himpunan Psikologi Indonesia (HIMPSI)
Indonesian Psychological Association

Proceeding of The 6th ASEAN Regional Union Psychological Society (ARUPS) Congress 2018

Driving Mental Revolution in the Psychological Century : Enhancing Psychological Services for a Better Future

Editor : Andik Matulesy, Tjipto Susana, Mirra Noor Milla, Anrilia E M Ningdyah

ISBN 978-602-96634-8-8



xii/ 953 pages/ 23 cm

Published by HIMPSI

Address:

Jl. Kebayoran Baru No. 85B

Kebayoran Lama, Velbak

Jakarta 12240

Phone : +62 21 72801625, 085282610736

Fax. : +62 21 72801625

Email : sekretariatpp_himpsi@yahoo.co.id

Website : <http://himpsi.or.id>

Conference Website : <http://arups2017.himpsi.or.id>

This Publication was supported by: ARUPS and HIMPSI

First edition: 2018

Hak cipta dilindungi Undang-Undang

Dilarang memperbanyak karya tulis ini dalam bentuk dan dengan cara apapun tanpa ijin tertulis dari penerbit.

Preface

The ARUPS Congress is a routine activity held every two years. The Congress aims to develop professional cooperation of Psychology regionally, especially among ASEAN countries and, internationally. The Indonesian Psychological Association (HIMPSI) hosted the 6th Congress. The 6th ARUPS Congress was held on 20 - 22 February 2018 at Discovery Kartika Plaza Hotel, Kuta, Bali. Activities in the Congress consist of: workshops; HIMPSI meetings with the International Union of Psychological Science (IUPsyS), the Asia Pacific Psychological Alliance (APPA), Pan African Psychological Union (PAPU); plenary and panel sessions; oral presentations; and, poster presentation.

Meeting between professional organizations of psychology aims to strengthen cooperation these organizations, regionally between ASEAN countries, Asia Pacific, and global region. Additionally, academic forums as part of the meetings aim to disseminate research results to improve the quality of psychological practices in each country. There are over 600 abstracts listed in the presentation list. For the purpose of maintaining quality, the scientific committee conducted paper selection. The result was as follows: 406 papers were selected for oral presentations and 65 papers were for poster presentations. Total number of attendances includes more than 300 people from 20 countries.

Workshops held on 20 February 2018 include:

1. Character Building Through Traditional Games with BERLIAN Method.
Speaker: Dr. Iswinarti, M.Si. (Indonesian Association of Developmental Psychology/IPPI).
2. A Learning Culture as An Essential Organizational Capital to Face Tough Business Environment.
Speaker: Prof. Dr. Andreas Budihardjo (Indonesian Association of Industrial and Organization Psychology / APIO).
3. ASD (Autism Spectrum Disorder) Early Identification and Intervention With TEACCH -
Speaker: Margaretha, S.Psi., P.G.Dip.Psych., M.Sc. (Faculty of Psychology, Airlangga University).
4. Preventing Anxiety and Depression in Young People: Super Skills for Life.
Speaker: Prof. Cecilia A. Essau (Roehampton University, England).
5. Methods and Procedures for Adapting Assessment Instruments for Psychological Research and Practices.
Speaker: R. Urip Purwono, PhD. (Faculty of Psychology Universitas Padjadjaran, Indonesia);
6. After A Disaster: An Introduction to Key Concepts to Meet the Psychological Needs of Those Affected.
Speaker: Associate Prof Clare Yeo and Dr. Tsao I Ting (Singapore);
7. How ASEAN Psychological Community Can Prepare Superior Human Capital for Global Competition: The Role of The Psychological Service of The Indonesian Army in Enhancing Resilience and Cultural Intelligence.
Speaker: Colonel Drs. Gunawan, DESS (Indonesian Association of Military Psychology/APMI);
8. Rightsizing: Business Organizational Performance Improvement.
Speaker: Dr. Sumaryono, M. Si. (Indonesian Association of Industrial and Organization Psychology/APIO);
9. Antenatal Resilience and Optimism Workshop: A Preview for Facilitator.

Speaker: Josephine Ratna, M.Psych, Ph.D, Psychologist (Widya Mandala Catholic University and Premier Hospital Surabaya);

10. Cognitive Interview: Technique to Obtain Information from Witnesses and Victims in The Criminal Justice System.

Speaker: Dra. Reni Kusumowardhani, M.Psi (Indonesian Association of Forensic Psychology / APSIFOR).

Keynote speakers gave their thoughts on February 21, 2018 after the opening ceremony, as follows:

1. Professor Nila. F. Moeloek, Minister of Health of the Republic of Indonesia.

Topic: The role of psychologist in community health services in Indonesia.

Nila Djuwita Farid Moeloek is the Minister of Health of the Republic of Indonesia since 27 October 2014. She actively participates as a speaker, resource person or moderator in a wide range of scientific meetings and workshops. She has also authored or co-authored more than 150 scientific papers and five scientific books. Dr. Moeloek also leads a number of high-profile organizations in Indonesia. Foremost among these are her positions as General Chairperson of the Indonesian Dharma Wanita (the largest women's organization in Indonesia whose members are comprised of the women and wives of civil servants throughout Indonesia), General Chairperson of the Indonesian Ophthalmologist Association, General Chairperson of the Indonesian Cancer Foundation, and Chairperson of Medical Research of Faculty of Medicine at the University of Indonesia. Dr Moeloek earned her medical degree in ophthalmology from the Faculty of Medicine at the University of Indonesia. After earning her position as a specialist consultant in ophthalmology in 1998, she devoted herself to pursuing her PhD in ophthalmology, and earned a cumlaude degree in 2003. In 2007, she earned her full professorship at the Faculty of Medicine at the University of Indonesia.

2. Dr. Sathasivian Cooper, President of the International Union of Psychological Science (IUPsyS).

Topic: The role of psychological organization at the local, regional and global levels in responding to human and social problems in psychological century.

Sathasivian Cooper is a clinical psychologist in South Africa. He plays numerous public roles, including Vice President of the International Social Science Council (October 2013-present) and President of the International Union of Psychological Science (July 2012-present). Cooper completed his undergraduate degree in psychology from the University of South Africa and his PhD at Boston University (1989). He received many awards, among others: 'Distinguished Contributions to the Advancement of International Psychology' award (2014) from the American Psychological Association and Violence Prevention Award from Roxbury Comprehensive Community Health Centre.

Plenary panel session features speakers who are experts in their fields from different countries, such as:

1. Doran French, PhD- Purdue University, West Lafayette, United States of America.

Topic: Social and emotional development of children and adolescents in four countries: China, Thailand, Korea and Indonesia.

Dr. French's research focuses on social and emotional development of children and adolescent. He has conducted research on peer relationships, friendships, conflict,

psychopathology, and adjustment (e.g., delinquency, substance use, school drop out). Over the past 17 years, he has been increasingly concerned with understanding how children develop within the context of culture. Much of his research has been in Indonesia, and also China, Thailand, and Korea. His current projects include research involving children in different cultures. He is also interested in studying Islam in Indonesia and exploring how religious involvement is associated with social competence.

2. Associate Professor Claire Thompson (Associate Professor of Clinical Psychology, Central Queensland University, Australia).

Topic: The cultural bases in the training of clinical psychologists in Asia.

Associate Professor Claire Thompson has a Bachelor of Arts (Honours) from the University of Queensland, a Masters in Clinical Psychology from Bond University, and a PhD from the University of New South Wales. She is a registered psychologist with the Australian Health Practitioner Regulation Agency (AHPRA) and the Singapore Register of Psychologists. Dr. Thompson has over 25 years of professional experience in clinical, research and teaching psychology. She has also worked in private practice, mental health service management and professional supervision of psychologists. She has taught psychology at undergraduate and postgraduate levels, at several institutions in Australia and Singapore. Her research interests, publications and conference presentations are in the area of clinical and counselling psychology, particularly mental health and cognition in older age and cultural aspects of Clinical Psychology training programs.

3. Kwartarini Wahyu Yuniarti, Prof., Clinical Psych, M.Med.Sc., Ph.D- Gadjah Mada University.

Topic: Illness perception, self-management and social support in health care in Indonesia. Professor Kwartarini Wahyu Yuniarti is the Director of Center for Indigenous and Cultural Psychology, Faculty of Psychology, Gadjah Mada University, Indonesia. She is also the Director of German Studies Center and the Country Representative of Asian Association for Social Psychology. Professor Kwartarini is on the Board of Asian Association of Health Psychology. Her key research focus is in the area of health psychology. Her research and publications include: Research on Asthma and emotion, comparative studies between those in Indonesia and in Germany; The assertiveness of passive smokers; Hygiene Behavior and Hepatitis A; Explorative Study on Health Anxiety among students in Aceh and Yogyakarta; Translating the Health Belief Model into Contextual Community Intervention A study on proper hygiene practices of mothers of children with diarrhea; Discrepancy between knowledge and behavior among mothers of children with diarrhea; Illness perception, stress, religiosity, depression, social support, and self management of diabetes in Indonesia.

4. Professor Roger Moltzen- Waikato University - New Zealand.

Topic: Creativity and talent development in Asia: Opportunities and challenges.

Professor Moltzen teaches in courses on human development, individual differences and the education of gifted children. His research interests are the psychology and education of gifted individuals. Professor Moltzen area of expertise include intelligence and creativity, talent development across the lifespan, the education of gifted and talented students, special education, teaching, learning and the curriculum and human development.

5. Dr. Cristina Montiel- Ateneo de Manila University.
 Topic: The role of psychology in creating social justice and democratic governance in Asia. Cristina Montiel is a peace/political psychologist and has been teaching at the Ateneo de Manila University for more than 35 years. She chairs the Research Cluster on Peace, Social Justice and Democratic Governance in her university. She is the recipient of the 2016 Outstanding Psychologist from the Psychological Association of the Philippines; and the 2010 Ralph White Lifetime Achievement Award from the American Psychological Association's Division of Peace Psychology. Montiel was managing editor of the Encyclopedia of Peace Psychology (Wiley-Blackwell, 2012), and editor of the volume on Peace Psychology in Asia (Springer, 2009). Her recent journal publications include Discursive construction of political categories and moral fields (Political Psychology, 2015); and Nationalism in local media during international conflict (Journal of Language and Social Psychology, 2014).

6. R. Urip Purwono, PhD.
 Psychometrician / Measurement Specialist, Center for Psychometric Studies Faculty of Psychology Universitas Padjadjaran Bandung, Indonesia.
 Topic: Test and the profession: revitalizing psychological testing. Urip Purwono is a senior lecturer and psychometrician at the Faculty of Psychology, Universitas Padjadjaran, Bandung, Indonesia. He received his Ph.D. (psychology) from the University of Massachusetts at Amherst, USA specializing in psychometrics, M.S. (Education) from Indiana University, Bloomington, Indiana, USA, M.Sc. (Psychology) from the University of Massachusetts at Amherst, USA, and Drs. (Clinical) in Psychology from Universitas Padjadjaran, Bandung, Indonesia. He joined Universitas Padjadjaran in 1985, founded and headed the Center of Psychometric Study, Assessment, and Evaluation. His teaching assignments includes undergraduate and graduate level courses in the area of quantitative research methodology, psychological assessment, test theories, and test construction. Urip Purwono is the author of many psychological tests used in Indonesia namely Test of Learning Ability, Comprehensive Cognitive Ability Test, General Cognitive Ability Test, and Multi Factor Personality Inventory. Currently involved in the development of CHC Based Intelligence Test in Indonesia, his research interest includes test theory, test construction, test adaptation, and structural equation modeling.

7. Yudi Latif, PhD., Head of the Presidential Work Unit of Pancasila Ideology- Republic of Indonesia.
 Topic: The way Pancasila engaging globalization.

Closing ceremony of the 6th ARUPS Congress was marked by Kecak dance performance which symbolizes spirit and optimism for the better future and closing speech from Mr. Urip Purwono, PhD - the newly elected President of ARUPS, focusing on the importance of continuing mutual positive cooperation between ARUPS country members and also with other international psychology organizations.

Dr. Seger Handoyo, Psikolog
President of HIMPSI

Content

Predicting Faculty Member's Work Engagement in Indonesia : Testing The Role Of Optimism, Perceived Organizational Support and Self Efficacy By: Aditya Nanda Priyatama et al.	1
The Influence of Private Conformity and Authority Obedience toward the Aggressiveness of Political Party Partisans By: Amanda Pasca Rini et al.	28
Three Moral Codes and Academic Dishonesty among Undergraduate Students in Indonesia By: Amni Syarifah et al.	38
Depression and Suicide Risk Among Adolescents: Exploring the Moderating Role of Benevolence and Goal-orientation By: Anna Marie C. Abrera	56
Sensitivity and Specificity of Indonesian Version of Hopkins Symptom Checklist-25 (HSCL-25) Anxiety Subscale as a Screening Test for Anxiety Symptoms in Indonesian Adolescents By: Annisa Prasetyo Ningrum and Sherly Saragih Turnip.....	66
Psychological Well-Being as Mediator of the Influence of Physical Condition and Psychological Condition of Classroom Towards Learning Qualities at Student Mercu Buana University By: Antonius Dieben Robinson Manurung et al.	81
Fading Technique (easy, practical and, applicative) to Improve the Brushing Teeth Skill of Children with Down Syndrome: A Single Case Study By: Aritya Widiarti	101
Self-Regulation to Buy A Car Measurement : Analysis Item with Rasch Model By: Asri Rejeki	109
Exploratory Study on Eating Behavior and Obesity of Selected 9- 12 years School-Aged Children in Metro Manila By: Cely D. Magpantay et al.	127
Service Quality and Consumer Loyalty: A Meta-Analysis Study By: Cicilia Larasati Rembulan et al.	141

Understanding personality structure using semantic relationships: a new lexical approach to personality trait modelling.	
By: CM Hew D Gill	161
Influence of Aggression Management Program in Reducing Aggressive Behavior of Filipino Children in Conflict with the Law (CICL)	
By: Consuelo Oliveros-Peralta and Jemerson N. Dominguez	181
The Application of Neuroscience in Early Childhood Education	
By: Desni Yuniarni	200
Bullies in School: How Does Their Social Information Processing Work?	
By: Dina Argitha et al.	208
The Relationship of Self-Esteem, Parents' Ethnic Socialization on Ethnic Identity Development of Java's Children	
By: Dyan Evita Santi	217
The role of identity in well-being and life engagement	
By: Elizaveta Berezina and C M Hew D Gill	235
Business Success Among Javanese Women Entrepreneurs	
By: Erita Yuliasesti Diah Sari	255
Social Media Engagement and Self-Regulated Learning of University Students	
By: Ermida Simanjuntak	271
Assertiveness Training for Support Quality of Work Life (QWL)	
By: Fajrin Intan Malikal Bulgis et al.	280
Meaning in Life and Proactive Coping: Two Meaningful Variables Related with Academic Stress Among College Student	
By: Fani Eka Nurtjahjo et al.	284
Career Path System for Supporting Quality of Work Life (QWL)	
By: Firlia Candra Kartika et al.	301
The Relationship between Attitudes about Husbands Violence Against Wives on Attribution Error to Victim of Domestic Violence	
By: Geby Chyntia Irwan et al.	306

Making Meaning, Making Change: A Case Study of Women Social Entrepreneurs' Trajectory from Personal Narrative to Community Development	
By: Gita Widya Laksmi Soerjoatmodjo	321
The Effectiveness of Basic Counselling Skills Training	
By: Hellya Agustina	335
The Role of Talent Management in Enhancing Job Satisfaction, Commitment, and Work Engagement of Generation Y Employees	
By: Ike Agustina and Nabila Ayu Gumilang	353
Prosocial behavior on commuterline passengers: Personality do matters	
By: Intaglia Harsanti and Asri Puspaningsih	368
Community Psychology: Breakthrough Indonesia Free Prisoner's Stocks	
By: Iqlima Pratiwi et al.	378
Manifestation of The Psychological Effects of Alcoholic Parents and Coping Strategies of Their Children	
By: Jacqueline Joy Ancheta Lising	383
How to Improve the Elderly's Psychological Well-Being? Community-Based in Implementing the six PWB's Modules	
By: Jatie K. Pudjibudojo et al.	405
Personology of Children in Conflict with the Law (CICL)	
By: Jemerson N. Dominguez	419
From One Kapwa to Another: Exploring the Giver's Experience and Feelings of Generosity	
By: Jennifer Evangelista	440
The Dynamics of White-Collar Crime	
By: Kalista and Fathul Himam	465
The Social Cognitive Model of Smoking Initiation Prevention in Adolescents	
By: Kamsih Astuti and Kondang Budiyani	480
Mindfulness and Well-Being in a Filipino College Sample	
By: Karina Therese Galang Fernandez et al.	494
Satisfaction of Basic Psychological Needs as a Mediator of the Relationship between Student's Perception of Meaning Support in Learning and Student Engagement	

By: Linda Primana et al.	507
Assertive Training on Company Employees CV X	
By: Luh Putu Ratih Andhini and Ni Made Sintya Noviana Utami	526
Correlation Between Work Family Conflict Self-Efficacy, Supervisor Support and Spouse Support with Work Family Enrichment on Female Worker in Tourism Sector	
By: Luh Putu Ratih Andhini and Artiawati	533
How People in Denpasar View Health Services and Officer in The Community?	
By: Made Diah Lestari et al.	540
The Relevance and Effectiveness of Social Skill and Autonomy Training for Young Adult with Autism for Support in Daily Livivng: A Description of Single Case Study	
By: Markus Nanang Irawan Budi Susilo and Indahjanti Sutanto	551
Sibling Relationship Quality among Out-of-State-Students at Faculty of Psychology Universitas Padjadjaran	
By: Maryam Nisywa et al.	557
Analysing Internet Addiction and its Psychological Risk (Depression, Anxiety, Strerss, and Loneliness) Among Undergraduate Students of UIN Malang	
By: Mely Santoso et al.	564
The Development of Learning Module of <i>Differentiated Instruction</i> Towards the Students with Special Needs in the Inclusive School, Yogyakarta City	
By: Mira Aliza Rachmawati et al.	577
Does Completing A Course of Family Developmental Psychology Influence Young Adult Perceptions of Marriage Readiness? Yes, It Does!	
By: Natasha Christy et al.	590
Psychology of Service in Terms of Standard Operating Procedures, Training and Career Development at CS Hotel in Ubud	
By: Ni Desak Made Santi Diwyarthi	601
Subjective Well-Being Elderly People in Panti Werdha	
By: Ni Made Sintya Noviana Utami and Luh Putu Ratih Andhini	608
Development Path of Culture Shock Theories	

By: Nidya Dudija	613
Item Analysis of Creativity Tests in the Field of Architecture: Quantitative and Qualitative Evidence in Test Development	
By: Niken Titi Pratitis and Urip Purwono	625
The Role of Colectivism Culture in Enterpreneurs Orientation of Dayak Tribe	
By: Nuraida Wahyu Sulistyani and Fendy Suhariadi	636
Application of Self-Regulation Empowerment Program (SREP) to Enhance Self-Regulated Learning And Achievement In Mathematics For Student With Underachievement In Middle School	
By: Putu Widiastiti Giri et al.	644
Construction and Validity of Psychoeducational Module for Parents about Sexual Education for Children with Autism Spectrum Disorders	
By: Rahma Kusumandari and Amherstia Pasca Rina	668
Language Switching Cost among Javanese-Indonesian Bilinguals	
By: Ratih Manggarsari and Margaretha	683
Social Entrepreneur’s Motivations: Case Study in Bandung, Indonesia	
By: Rayi Noormega and Yus Nugraha	697
The Influence of Religiosity towards Premarital Sex among Adolescents	
By: Refil Laurensia Better and Clara R.P. Ajisuksmo	708
The Influence of Personality Traits with The Tendency To Conduct Altruism Behavior of AIDS Patients In Communities In South Kalimantan	
By: Rendy Alfiannoor Achmad	726
The Effectiveness of Emotional Freedom Technique and Therapeutic Communication to Reduce the Anxiety in Female Cervix Cancer Patients	
By: Retno Indaryati et al.	737
Correlation Between Interpersonal Communication Skills with Conflict in Dating Relationship at Faculty of Educational Psychology, State University of Malang	
By: Rizka Fibria Nugrahani et al.	751
Training Coaching & Counseling to Support Quality of Work Life (QWL) on PT. X.	

By: Rizky Amelia et al.	761
Description of Mastery Oriented Students in Junior High School Students Living in Kiram Atas Village, Banjar District of South Kalimantan	
By: Rusdi Rusli and Cahaya Kamilah	768
Case Study About Description of Impulsive Buying as Consumen Behaviour Of Student In Economics Faculty LambungMangkurat University Banjarmasin	
By: Rusdi Rusli and Gusti Medinda Ridha Puteri	783
Inhibitory Control and Role of Sex	
By: Satrio Priyo Adi et al.	796
Religious Tolerance and Perceived In-group Superiority of College Students In A Post Conflict Area in Indonesia	
By: Sherly Saragih Turnip and Lerivia Maharani	808
The Psycometric Analysis of Indonesian Happiness Scale	
By: Sofa Amalia	821
Description of Stress and Its Impact on College Student	
By: Sugiarti A. Musabiq and Isqi Karimah	832
The Power of Gratitude in Indonesia: Does Prosocial Behavior and Social Support Contribute to Gratitude?	
By: Taufik Akbar Rizqi Yunanto	841
Entrepreneurship Motivation of Riau Malay People	
By: Tengku Nila Fadhlia and T. Nindya Eka P. N	852
Peaceful Heart in Students of Hijrah Community viewed from Taubat and Forgiveness	
By: Tia Prasyatiani et al.	865
The Influence of Growth Mindset and Emotional Intelligence on Work Achievment of Lectures in Mercu Buana University	
By: Tika Bisono et al.	878
Traumatic Stress on Police: Marital Status and Thinking About Suicide Ideation	
By: Tugimin Supriyadi and Erik Saut H Hutahaeen	901
Employee’s Voice Behavior: A Literature Review and Conceptual Development	
By: Unika Prihatsanti et al.	909

The Influence of Personal Factors and Family Involvement on Career Adaptability among 9th Grade Students in Indonesia

By: Wahyu Indianti and Airin Yustikarini Saleh 924

Perceived Needs of Employee Counseling Among University Staff

By: Yulianti Dwi Astuti 936

Predicting Faculty Member's Work Engagement In Indonesia: Testing The Role Of Optimism, Perceived Organizational Support And Self Efficacy

Aditya Nanda Priyatama

Fakultas Psikologi
Universitas Airlangga

Muhammad Zainudin

Fakultas Psikologi
Universitas Airlangga

Seger Handoyo

Fakultas Psikologi
Universitas Airlangga

Abstract

One of the human resources that affect the process of quality development in universities in Indonesia is lecturer. The roles of lecturer one of them is to participate in realizing the goals of national educational to create intellectual life of the nation and able to improve the quality of Indonesian's citizens become better and more civilized. The contribution of lecturers to Indonesian universities will be important, if it is done with effective actions and behave correctly, not only the effort but also the direction of the attempt, the characteristics within the lecturer, the effort or the willingness to work, and also support from universities is very important for the success of lecturers performance, thus every lecturer needs to know with certainty the main responsibility, performance, and can measure itself according to their indicators of success. One possible thing that will improve the performance of the organization is to see how well the lecturer's performance is. Some studies related to work engagement include organizational support and optimism perceptions. This research has purpose to see some psychological construct related to perception of organizational support and optimism have an effect on work engagement by using self- efficacy mediator variable at college lecturer in Surakarta. The sample used in this research was 393 lecturers of Sebelas Maret University Surakarta. Data was analyzed by using Structural Equation Modeling (SEM) using Lisrel 8.70 program. The result of the analysis showed the fit model and there is a significant influence between the perception of organizational support and optimism on the engagement of lecturer with mediated by self- efficacy, with RSMEA value: 0.082, CFI: 0.98., GFI: 0.92., SRMR: 0.045

Keywords: Work engagement, perception of organizational support, self efficacy, and optimism

Address for Correspondence:

Aditya Nanda Priyatama, Fakultas Psikologi Universitas Airlangga, Surabaya, Jawa Timur, anandapriyatama@gmail.com

Introduction

In accordance with the functions and objectives of education of Indonesia as listed in the Law of National Education System Number 20 of 2003 article 3, suggests that national education functions to develop the ability and form the character and civilization of a dignified nation in order to educate the nation and develop the potential of learners to be faithful to Almighty God, glorious, healthy, knowledgeable, capable, creative, independent and become a democratic and responsible

citizens. In addition to the above mentioned Law on National Education, Law No. 12 of 2012 on higher education Article 4 also explains that higher education functions to develop the ability and form the character and civilization of a dignified nation in order to educate the nation's life, develop an innovative, responsive, creative, skilled, competitive, and cooperative academic community through the implementation of Tridharma; and develop science and technology by observing and applying the humanities value. In line with the above statement, higher education is a necessary form of education in the context of achieving that goal.

One of the human resources that affect the process of quality development of universities in Indonesia is lecturer. Lecturer is one of the most essential components that has a role to participate in realizing the national educational goals in the form of intellectual life of the nation and able to improve the quality of Indonesian's citizens become good and civilized. In accordance with Law Number 14 of 2005 on teachers and lecturers, the Law has been explained about the understanding of lecturers as professional lecturers and scientists with the main task of transforming, developing and disseminating science, technology and the arts through education, research and community service (Chapter 1, article 1, verse 2).

In order for organizational success to be achieved, appropriate effort is needed, in order to maintain the human resources within the organization. One effort that can be done is engagement. Engagement is the compliance of an individual in the organization concerning vision, mission and corporate goals in the work process within the organization. Working engagement within the lecturer is built through the process, it needs a long time and high commitment from leaders also from personal. For that, it takes consistent leadership in mentoring employees and lecturers. In creating work engagements, organizational leaders are expected to have some skills. Some of them are communicating techniques, giving feedback techniques or feedback on what has been done and performance appraisal techniques (McBain, 2007).

Many studies have examined the characteristics of work contexts that address the theme of work engagement. However, some personal characteristics may also affect engagement. For example, when individuals are optimistic about the future, engagement is more likely to occur (Xanthopoulou, Bakker, Demerouti, & Schaufeli, 2007). The study examined the roles of three personal resources (self-efficacy, self-esteem based organization, and optimism) in predicting employee engagement. The results showed that employees are very effectively involved, they believe that they can meet the demands faced in a set of contexts. In addition, the workers involved

believe that they will generally get good results in life (optimistic) and can fulfill their needs by participating in an organizational role. Not only that, those three personal resources also make a unique contribution to explain the variants in employee engagement over time, beyond the impact of employment sources and previous levels of engagement (Bakker, Schaufeli, Leiter, & Taris, 2008).

Some of the above studies show varied relationship with employee engagement. Our research will try to look at some theoretical constructs that can be related to work engagement, one of which is psychological capital or commonly called psychological modal. Psychological capital is the positive state of psychology of a person consisting of the characteristics of self-efficacy in the tasks, optimism, hope, and the ability to conceive and when faced with a problem (resilience) (Luthans et al., 2007).

Schaufeli & Bakker (2003) state that work engagement is basically influenced by two things, namely JD-R model (jobdemand-resources model) and psychological capital (psychological modal). The JD-R model covers several aspects such as the physical, social, and organizational environment, salary, career opportunities, supervisor support and co-workers, and performance feedback. As for the psychological capital include self-confidence (self efficacy), optimism, hope and resilience. The research we will do besides looking to see the influence between optimism and the perception of organizational support with work attachment, will also see the extent to which things related to self efficacy mediate the relationship between the two. Self efficacy is thought to mediate for the maximum achievement of psychological capital in obtaining employee engagement. Efficacy is widely known to come from 4 main sources to be submitted that fit with employee engagement. Individuals with high efficacy are usually characterized by their persistence in perseverance, driven by their belief in future success. Low Efficacy appears to predict burnout, the opposite of engagement. Therefore, the higher the self efficacy in a person then it is believed the employee's engagement to the organization will be higher too.

Research conducted by Eisenberger et al (1986) showed that perceptions of organizational support or perceptions of organizational support (POS) can improve the emotional engagement of employees to the organization. In his research, Eisenberger et al (1986) defines POS as a form of employees' belief in the organization, that the organization appreciates the contributions and efforts made by employees and care about their welfare. Employees with socio-emotional needs are met more easily committed to the organization than those who do not.

One of the major theories underlying the reason why we want to do this research is the field theory of Kurt Lewin, which emphasizes human-environmental interaction with the formula $B = f(E, O)$. Behavior is a function of the environment and organism. The essence of this theory is the existence of Life Space (LS) which is a constellation of the factors that determine both individual and environment. One's behavior (B) can be described as a function of the Life Space (LS) where LS consists of personal factors (P) and environment (E). In relation with this research, Behavior (B) in this research is engagement, Environment (E) in this research is perception of organizational support, and Organism (O) in this research is self efficacy and optimism.

Prior Model Of Work Engagement

The concept of engagement was popularized by Kahn (1990), which relates this concept to the idea of a psychological presence. By definition, engagement refers to conditions when individuals express themselves physically, cognitively, and emotionally in their roles. Kahn (1990) argues that engagement culminates in a state called the psychological presence, a state in which the inner aspects can be fully expressed. In these circumstances, individuals do not need curb their beliefs, values, thoughts, feelings, trends, and relationships. All of these aspects are realized in behavior at work. Kirkpatrick, (2007) also defines engagement as an involvement to a job consisting of interest, enthusiasm, and employees investment in doing their work. Further Kirkpatrick argues that empirical studies have revealed that engagement is associated with positive behaviors and produces results for both employees and organizations. Schaufeli et al. see attachment in different constructs and it is defined as the fulfillment of positive, work-related circumstances and is accompanied by a thought that is characterized by vigor, dedication, and absorption. (Schaufeli, Salanova, Roma, & Baker, 2002).

Nelson and Simmons, (2003) have defined engagement more completely such as when employees feel positive emotions for their work, think that their work is meaningful, consider their workload to be managed, and have expectations about the future of their work (Attridge 2009).

The Importance of Perceived Organizational Support

Perception of organizational support is a concept developed based on the theory of social exchange (social exchange theory). In social exchange theory it is mentioned that work as an exchange between effort and loyalty with perceived benefits (tangible benefits) such as, salary and compensation and social rewards (Gould, 1979; Levinson, 1965; Rhoades & Eisenberger, 2002).

When the individual is treated well by the other side, then the norm of reciprocity in which the individual will respond with good treatment (Gouldner; Eisenberger et al., 2001). This also applies in relationships between employees and organizations. Employees will show effort and loyalty to the organization, if the organization also shows appreciation for the contribution made by employees and care about their welfare.

Eisenberger et al. (1986) defines the perception of organizational support as a growing global belief in employees about the extent to which organizations evaluate contributions and care about their well-being. This belief emerges based on the employee's personification in viewing the treatment provided by the organization as an indication of the extent to which the organization assesses its contribution and cares for the well-being of its employees.

The perception of organizational support plays a role in meeting the socio-emotional needs of the employee and providing assurance to the employee of the need for help. This determines the organization's readiness to reward and compensate for the efforts made by employees for the benefit of the organization. The perception of organizational support is also assessed as a guarantee of the availability of assistance from the organization in times of need.

The Mediational Role of Self-Efficacy

Self efficacy is defined as a person's belief in his ability to exert minds to obtain a special outcome (Luthans and Youssef, 2004). In 1998, Stajkovic and Luthans in Luthans, Youssef and Avolio (2007) gave their opinion on a broader definition of self efficacy than the prior understanding, a belief (confidence) about one's ability to urge the motivation, reason and sequence of actions needed to successfully carrying out specific tasks within a context. According to Maddux (2002), as a belief, self efficacy is declared to be the most important determinant in the selection of behaviors to bind him and how persistent a person faces obstacles and challenges. While Liam, Page and Donohue (2004) describe self efficacy simply as an openness to the challenge and the desire to spend effort in the pursuit of success.

According to Bandura (1977), self efficacy is a belief that one can execute the behaviors necessary to produce a successful outcome. In addition, Saks and Gruman (2011) research states that self efficacy is important to get individuals bound. They found a positive relationship between job fit perceptions, positive emotions and self-efficacy with employees' engagement to new employees. New individuals joining an organization with great self-efficacy will feel safer and psychologically willing to tie themselves into their new roles (Saks and Gruman, 2011).

With regard to self efficacy as a mediator variable, according to Baron and Kenny (1986); (Saks, 2006) there are three conditions that must be met to form mediation. First, the independent variable must be associated with the mediator variable. Second, the mediator must be related to the dependent variable and the third, the significant relationship between the independent variable and the variable will be reduced or no longer significant when controlling the mediator. All three conditions are theoretically fulfilled, so the model offered in this research is to make self efficacy variable as mediator from perception of organizational support and optimism to the engagement of work to lecturer in Indonesia.

Optimism as a Psychological Capital

Optimism is an important part of Psychological Capital consisting of self efficacy, optimism, resilience and hope (Luthans, et al., 2007). Optimism is a positive approach to life (Myers, 2002). Optimism has important implications for both physical and psychological health (Carver and Scheier, 2009). According to the Indonesian dictionary, the definition of optimism is the attitude or outlook of life that sees all things well and expect good results as well. In psychological studies, optimism is expressed as a hopeful expectation in certain situations (Scheier and Carver, 1988; Reivich and Gillham, 2003). In general, optimism is associated with a variety of health conditions. According to Reivich and Gillham (2003), optimistic individuals will tend to experience fewer symptoms of depression and physical symptoms, as well as more effective coping strategies than non-optimistic (pessimistic) individuals.

Seligman (1990) describes optimism and pessimism associated with the tendency of individuals to think about the causes of events that occurred in his life. An optimistic individual will tend to relate the problem to something as temporary, specific and external. While pessimistic individuals will tend to connect the problem they experienced as something permanent, comprehensive and internal. Therefore, optimism is associated with higher rates of motivation, achievement and physical well-being, as well as lower rates of depressive symptoms (Reivich and Gillham, 2003).

Hypothesized Model

Hypothesis 1: Self Efficacy Affects Work Engagement

The theories put forward by Bandura (1986, 1997 (Luthans et al., 2007) explain that self efficacy can be defined as one's beliefs about his ability to mobilize the motivations, cognitive resources, and actions necessary to successfully perform certain tasks in a particular context.

Individuals with self efficacy have characteristics: 1. have high goals, 2. have the ability to solve challenges, 3. have motivation, 4. invest the effort required to achieve goals and., 5 despite facing obstacles, individuals is persistent. Individuals with high efficacy is assumed to be able to work well and consciously become part of the organization.

Hypothesis 2: Perceptions of Influential Organizational Support on Work Engagement to Self Efficacy Mediator Variables

One that is assumed to be related to work attachment is related to the environmental conditions of the organization. Environmental conditions in the organization have a positive contribution in interpreting the lecturer's work engagement. Lecturers will have perceptions as to the extent to which organizations assess their contributions and the extent to which organizations care about their well-being (Eisenberger, Stinglhamber, Vandenberghe, Sucharski, & Rhoades, 2002). Perceptions of organizational support relate to matters expected by employees, such as rewards from the organization, favorable working environment and support, and support from colleagues and leader (Rhoades & Eisenberger, 2002). Individuals will assess how much support the organization provides to them and in response to it, they will appreciate and help achieve organizational goals (Safari, TamiziFar, & Jannati, 2012). Positive support from elements within the organization, including leader and co-workers, will make the work environment conducive so that employees will be encouraged to work better (Lusdiyanti, 2011).

Hypothesis 3: Optimism Influences Work Engagement With Self-Efficiency Mediator Variable

Optimism is one of the variables that can affect the quality of human life. In fact, optimism has a fundamental role in the management of adjustment to the precarious state and the achievement of goals. Through adjustment management of personal goals and development and by using active coping strategies, optimistic individuals are significantly more successful than pessimistic individuals to face undesirable events and when important goals in life have not been achieved (Worsch and Scheier, 2002). In addition, McGee (2006) in the Office of Chief Researcher (2007) emphasizes that good adaptability is one factor that can predict employee engagement.

Social issue research center (2009) also states that optimism plays an important role in human experience as a positive aspect in thinking about the future. Individuals who have optimism will evaluate outcomes within the framework of positive thinking and expect positive results as a result of the effort that the individual has performed, whereas the individual who has no optimism

(pessimism) will evaluate the outcome in a negative frame of mind and expect a neutral or negative result (Tuten and Neidermeyer, 2004).

A similar opinion is also expressed by Scheier, Carver and Bridges (1994) that optimism can make individuals more likely to have positive expectations about their future, whereas individuals who lack optimism (pessimism) will tend to have negative expectations about their future. Michelman (2004) in the Office of Chief Researcher states that one of the stimulus of employee engagement is the setting of employee expectations. An optimistic employee is an employee who has a positive expectation of the future (Carver and Scheier, 2002) so that the employee is more engaged to his or her job and company than an employee with no optimism (pessimism).

In 2003, Carver and Scheier stated that the optimistic individual assumes that the difficulties will be dealt successfully. An optimistic individual assumes that he or she is very talented, because the individual works hard, blessed, lucky, has friends in the right place or a combination of these things, so that individuals can get the desired results (Carver and Scheier, 2003). When faced with unwanted events or failures, the optimistic individual will explain that it is not because of something that is in him, not permanent and limited only to specific circumstances (Hefferon and Boniwell, 2011).

Stein and Book (2001) stated that optimism allows individuals to self talk about themselves so as to increase resilience to face failure or negative events. Optimism makes individuals believe that the obstacles arising in their lives will be handled successfully. While pessimism will make individuals expect failure to face obstacles (Carver and Scheier, 2002). Differences in attitude to face obstacles will affect the way the individual to face stress. Khalatbari's research (2012) found that optimism has a positive correlation with mental health. Individuals who have optimism in facing obstacles will tend to frame their minds with a positive mindset, thereby avoiding stress that can lead to disruption of one's mental health. Supporting these statements, optimism is a variable that provides benefits of physical and psychological well-being and is usually associated with positive psychology (Scheier, et al., 1994).

Broadly, the results of the literature review stated that optimism has a very positive impact on work attitude that is job satisfaction (Rauf, 2010a). Job satisfaction has an emotional, cognitive and behavioral component. Emotional components refer to feelings about work (boredom, anxiety and excitement), cognitive components refer to beliefs about a job (feelings about a job that is

mentally demanding and challenging), while the behavioral component refers to the action of an individual related to work (Ahmed , 2012). In the study conducted by Ahmed, it was found that optimism has a positive relation with job satisfaction. Subsequently on a review of different title, Rauf (2010b) stated that optimism fastens a sense of belonging to work. When the individual has such feelings, then the sense of responsibility towards the achievement of organizational goals will increase, which will ultimately increase productivity.

Schmidt (2004) in the Office of Chief Researcher (2007) states that job satisfaction and commitment encourage employee engagement. Individuals who are satisfied with their work and organization will tend to be more committed than individuals who are dissatisfied with their work and organization. A similar opinion is also expressed by Robinson, et al (2004) that training and development, communication and job satisfaction are decisive factors that can make the individual feel valuable, thus making him more engaged to his company. Individual satisfaction with his work is one of the items used in measurement of engagement by Wellins, et al (2008).

Based on the above elaboration, it can be seen that the optimism makes the individual has active coping, mental health, positive mood, little stress experience and positive thinking. In addition, optimism also makes individuals feel job satisfaction. Through the positive impacts of optimism in the workplace, the individual will have a feeling of joy towards his work and feel a sense of responsibility in the pursuit of organizational goals, which will ultimately increase the level of individual engagement within his organization, and ultimately the individual has an engagement to work in the organization.

Method

Participant

The subject of this research is 393 lecturers working at Sebelas Maret University Surakarta with the criterion has worked at least 1 year as a lecturer at Sebelas Maret University. Faculties used in this research are 10 faculties spread in Sebelas Maret University Surakarta. The sample in this research is the lecturer of the state university in Surakarta which has the following characteristics 1. Lecturer with rank/class of minimal expert assistant, 2. Minimum 2 years working period, 3. Age 30-65 years.

Procedure

The researchers conducted a research-scale tryout by distributing 400 research-scale booklets to 400 lecturers working at Sebelas Maret University Surakarta. After waiting for

approximately 3 months of scale spreading, the researchers got the scale back 375 copies and 20 damaged scales, due to incompleteness in filling, so the total scale back to the researchers that researchers can do the test of differentiation and reliability as much as 355 scale. After the reliability and validity test, the researcher gets the scale to be given to the research subject of 400 lecturers. After dissemination of research scale given to lecturer, from 400 scale back 393 scale can be continued at analysis stage, while 7 pieces of scale can not be analyzed because of incomplete in filling, so that the number of sample that made as subject in this research are 393 lecturers.

Measures

This study used four research scales, namely the scale of organizational support, the scale of work engagement, the scale of self efficacy, and the scale of optimism. The four scales are the Likert model scale, each scale has the characteristics of four alternative answers that are separated into favorable and unfavorable statements moving from highly unsuitable to very suitable. At the POS scale the item of different power index moves from 0.468 up to 0.799 with cronbach alpha of 0.965. The scale of the working engagement of the item different power index moves from 0.250 to 0.491 with cronbach alpha of 0.768. Self efficacy scale differential power index item from 0.404 to 0.655 with cronbach alpha of 0.899. The scale of optimism, the item different power index moving from 0.348 to 0.625 with cronbach alpha of 0.874. By using confirmatory factor analysis, it is found that the scale items are declared valid and reliable as following table.

Table 1. Confirmatory Factor Analysis of Work Enggement Scale

Indicator	λ	t_{λ}	$1-\epsilon$	$t_{1-\epsilon}$	Note
Engagement 1	0,98	0.46	0,04	0.01	Valid, Reliable
Engagement 2	0,62	0.28	0,61	0.12	Valid, Reliable
Engagement 3	0,66	0.35	0,56	0.15	Valid, Reliable

Table 2. Confirmatory Factor Analysis Perception Scale of Organizational Support

Indicator	λ	t_{λ}	$1-\epsilon$	$t_{1-\epsilon}$	Note
POS1	0,79	18,61	0,37	12,49	Valid, Reliable
POS2	0,87	21,53	0,24	11,10	Valid, Reliable

POS3	0,93	24,20	0,13	7,62	Valid, Reliable
POS4	0,91	22,92	0,18	9,67	Valid, Reliable

Table. 3 Confirmatory Factor Analysis of Self Efficacy Scale

Indicator	λ	t_λ	$1-\epsilon$	$t_{1-\epsilon}$	Note
EFI1	0,83	19,07	0,32	9,70	Valid, Reliable
EFI2	0,87	20,29	0,25	8,02	Valid, Reliable
EFI3	0,85	19,78	0,28	8,76	Valid, Reliable

Table. 4 Confirmatory Factor Analysis of Optimism Scale

Indicator	λ	t_λ	$1-\epsilon$	$t_{1-\epsilon}$	Note
OPT1	0,79	17,08	0,38	9,47	Valid, Reliable
OPT2	0,88	19,70	0,22	5,45	Valid, Reliable
OPT3	0,74	19,58	0,45	10,77	Valid, Reliable

From the four Confirmatory Factor Analysis, it is found that to evaluate the manifest (observed) variables that make up the latent variable can be done by testing the structural coefficient generated by t test. Besides, it also used standardize solution. The overall results of the t test and the standardize solution show a valid and reliable item.

Results

Based on the model test conducted, it shows that the model is fit. Some characteristics of goodness of fit indicate fit can be seen in table fit model test as below.

Table.1 Goodness of fit model

Statistic	Value	Criteria of Fit	Note
Chi Square	0,000	$p > 0,05$	Not fit
RMSEA	0,008	$\leq 0,1$	Fit
GFI	0,92	$> 0,9$	Fit
SRMR	0,045	$< 0,05$	Fit
AGFI	0,88	$> 0,9$	Not Fit

The 6th ASEAN Regional Union Psychological Society (ARUPS) Congress

PGFI	0,62	>0.9	Not Fit
NFI	0,98	>0.9	Fit
NNFI	0,98	>0.9	Fit
PNFI	0,76	>0.9	Not Fit
CFI	0,98	>0.9	Fit
IFI	0,98	>0.9	Fit
RFI	0,97	>0.9	Fit

From the results of the above fit model, it can be seen that some fit model criteria have been met, i.e. on RMSEA, GFI, SRMR, NFI, NNFI, CFI, IFI and RFI indicated fit criteria. Test t model can be seen as the following picture.

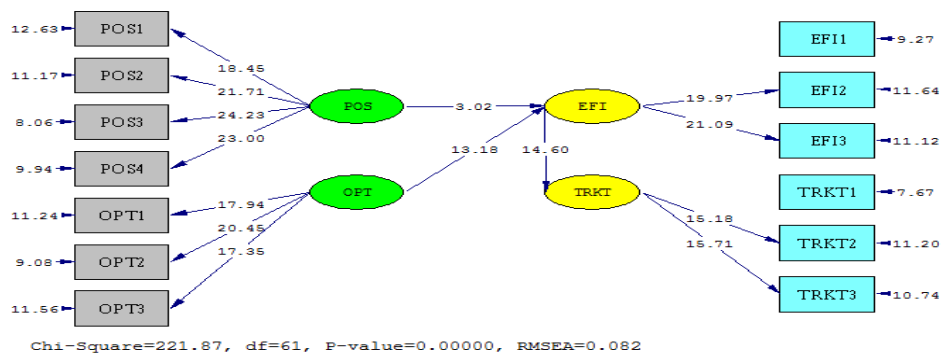

Picture 1. T Model Test

While standardized solution can be seen in the picture as follows.

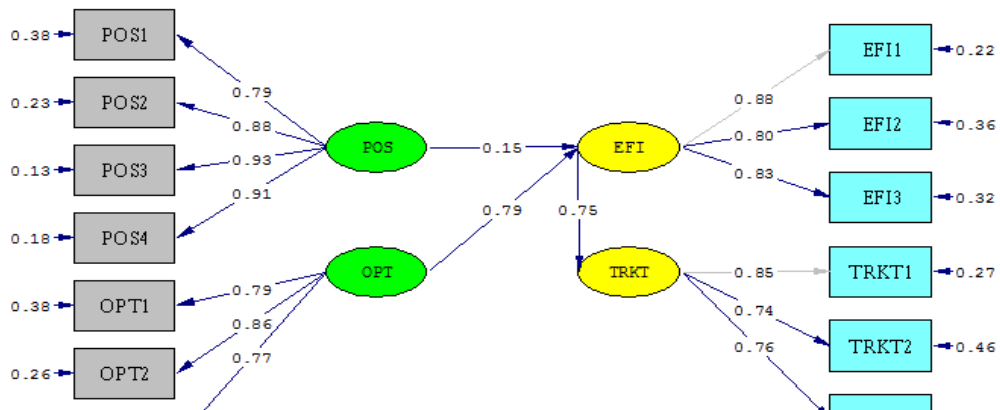

Picture 2. Standardized Solution Model

Hypothesis Results

1. There is a positive influence between self efficacy and work engagement with t value is 14.60, so that the more self efficacy is, the higher work engagement has the lecturer. Based on the result, hypothesis 1 is accepted
2. There is a positive influence between the perception of organizational support with self efficacy with a t value of 3.02 so that the higher the value of the perception of organizational support is, the higher the self efficacy is. Based on this result, the second hypothesis is accepted
3. There is a positive influence between optimism on self efficacy with t value of 13.08 so that the higher the value of optimism is, the higher the self efficacy is
4. Self efficacy becomes a good mediator variable between the perception of organizational support and optimism with work engagement

Table 1. Categorization of research data

Variable	Categorization				
	Very low	Low	Moderate	High	Very high
Work engagement	0	1	16	217	159
		(0,25%)	(4,07%)	(55,22%)	(40,46%)
POS	1	2	65	210	115
	(0,25%)	(0,51%)	(16,54%)	(53,44%)	(29,26%)
Self Efficacy	0	2	69	203	119
		(0,51%)	(17,56%)	(51,65%)	(20,28%)
Optimism	0	0	25	212	156
			(6,36%)	(53,94%)	(39,70%)

From the research data above, it can be seen that the work engagement has high average categorization value for 217 people (55.22%), high average POS variable for 210 people (53.44%), self efficacy variable high average for 203 people (51.65%), high optimism variable for 212 people (53,94%).

Discussion

The research we have done will look at some theoretical constructs that can be related to work engagement, one of which is psychological capital or commonly called psychological modal. Psychological capital is a person's positive psychological state which consists of the characteristics of self-efficacy in all tasks, optimism, hope, and ability to survive and advance when faced with a problem (resilience) (Luthans et al., 2007).

The results of this study support what has been proposed by Schaufeli & Bakker (2003) which state that work engagement is basically influenced by two things, namely JD-R model (jobdemand-resources model) and psychological capital (psychological modal). The JD-R model covers several aspects such as the physical, social, and organizational environment, salary, career opportunities, supervisor support and co-workers, and performance feedback. As for the psychological capital include self-confidence (self efficacy), optimism, hope and resilience.

Sweetman and Luthans, (Bakker and Leiter, 2010) argue that there is a positive relationship among efficacy, optimism, hope, and resilience with work engagement. Efficacy is widely known to come from 4 main sources to be submitted that fit with employee engagement. Individuals who have high efficacy are usually characterized by their persistence in perseverance, driven by their belief in future success. Low Efficacy appears to predict burnout, the opposite of engagement. Therefore, the higher the self efficacy in a person then it is believed the employee's engagement to the organization will be higher too. According to Bandura (1977), self efficacy is a belief that one can execute the behaviors necessary to produce a successful outcome. In addition, Saks and Gruman (2011) research states that self efficacy is important to get individuals bound. They found a positive relationship between job fit perceptions, positive emotions and self-efficacy with employees' engagement to new employees. New individuals joining an organization with great self-efficacy will feel safer and psychologically willing to tie themselves into their new roles (Saks and Gruman, 2011).

On the optimism side, our research is also in line with Seligman's opinion (Seligman & Schulman, 1986) which describes optimism as an attribute measured by explanatory style. An

optimistic individual who achieves success will behave in a general way (I can succeed from scope to scope) consistently (I can always succeed) internally (I am the one who created this success). When a failure occurs, the individual will be specific, inconsistent, and externally. Another explanation of the optimism put forward by Carver and Scheier (2003) that the optimistic individual expects good things to happen to him, has significant attitude and cognitive implications. It is important to know that the psychological modes assign the value of realistic optimism, because unrealistic optimism leads to negative outcomes (Seligman, 1998). An optimistic individual is responsible for what is being done and has hope for a positive outcome. Good psychological availability will increase engagement (Kahn, 1990). Overall, the psychological capital optimism component is directly related to the devotion and absorption component of the work engagement.

In relation to educational institutions, the results of this study show that optimism is needed to make educational institutions go forward and develop well. Human resources that exist in educational institutions are also expected to have an attitude of optimism.

Studies conducted by Christian and Slaughter (2007); Halbesleben (2010); (Albrecht et al, 2010) state that some of the predictors of engagement include social support, self efficacy, optimism and organizational climate. Self Efficacy and optimism play a role in improving employee engagement with supportive organizational climate. It is obtained when employees perceive the organization to provide support to the work done by employees. The above research shows a strong influence between self efficacy and supportive optimism of our research results.

Wiley, et al (2010); Albrech, et al (2010) also found a number of facts that work engagement will be well established when the individuals within the organization feel energized and have the opportunity to develop. Organizations have a stake in providing opportunities to develop individuals, without which it is unlikely that individuals will have an engagement to the organization. The results also has relevance to the results of our research. One of the efforts that will be made by the organization to maximize the potential that exists in the company is to provide an individual opportunity to develop well, so that individuals will maximize the potential to make the organization grow rapidly.

Sweetman and Luthans (2010); Baker and Leiter (2010) state that their preliminary research indicated that among self efficacy, optimism, hope and resilience in relation to work engagement, there is a mediator variable namely positive emotions. Specifically, high positive emotions will increase the effect of self efficacy, hope, optimism and resilience to employee engagement.

Sweetman and Luthans (2010) mentioned that these positive emotions are related to the behavior of employees in the organization. Halbesleben (2010); Baker and Leiter (2010) argue that both hypotheses related to the linkage between social support, autonomy, feedback, positive organizational climate, and self efficacy are proven. From the results of his research, there is a link between autonomy and self efficacy that has a high relationship with the work engagement itself. Xanthopoulou et al (2009a); Baker and Leiter (2010) states that personal resources containing self-efficacy, confidence, and optimism, along with work resources containing work autonomy, supervisory coaching, employee performance and employee development opportunities have very close relationship with work engagement. Interpersonal resources and work resources complement each other in making a positive contribution to the development of work engagement. In another study Xanthopoulou et al (2009b) also investigated that self efficacy and optimism become two of several criterias for the meaning of the work engagement itself.

Implications for Reserach

The results showed that the model fits by entering the self efficacy variable as a mediator variable. Self efficacy will be a meaningful variable in the development of the work engagement of the lecturer. The results of our research are in accordance with the research conducted by Bandura (1997) which states that self efficacy is a person's belief about his ability to mobilize motivation, cognitive resources, and actions to do which is necessary to successfully perform certain tasks in a particular context. Self-efficacy becomes a good mediator variable for organizational support perception variable and optimism on work engagement to lecturer.

Study Limitations

The research we have done found some things related to the characteristics of work engagement of the lecturers at the Sebelas Maret University. The interesting thing that can be used as reference in this study is the subject of research derived from educational institutions. Some of the limitations of this study are related to the limited scope of the study, and the amount of samples that can certainly be supplemented by widening the research area. Despite its weaknesses due to the limited scope of the study, this study was able to establish several major theories related to engagement and self efficacy.

Conclusion

1. Self-efficacy becomes a good mediator between the perception of organizational support and optimism, with work engagement of lecturers.

2. The higher self efficacy, optimism, and perception of organizational support are, the higher the lecturer's work engagement is.
3. The existence of the results of this study is expected to answer the controversy and uncertainty theory found in some psychological literature related to the work engagement. The problems related to lecturer professionalism related to the certification of lecturers require very deep attention, so it is interesting to be used as one of the topics in the research and the result of this research reveals that the work engagement of the lecturer will be good if accompanied by organizational support to the improvement of lecturer's performance .

References

- Ahmed, Mozumdar Arifa. 2012. The role of self-esteem and optimism in job satisfaction among teachers of private universities in Bangladesh. *Asian Business Review*, Volume 1, No. 1, pp: 114-120.
- Albrecht, Simon L. 2010. *Handbook of employee engagement: perspectives, issues, research and practice*, pp: 3-19. UK: Edward Elgar Publishing Limited.
- Aspinwall, Lisa G dan Staudinger, Ursula M. 2003. *A psychology of human strengths: some central issues of an emerging field*, pp: 9-22. US: American Psychological Association.
- Avey, James., Wernsing, Tara S dan Luthans, Fred. 2008. Can positive employee help positive organizational change? Impact of psychological capital and emotions on relevant attitudes and behaviors. *The Journal of Applied Behavioral Science*, Volume 44, No. 1, pp: 48-70.
- Azwar, Saifuddin. 2007. *Penyusunan skala psikologi*. Yogyakarta: Pustaka Pelajar.
- _____. 2011. *Sikap manusia: teori dan pengukurannya*. Yogyakarta: Pustaka Pelajar.
- Bakker, Arnold B. 2010. Engagement and job crafting: engaged employees create their own great place to work. Edited by Albrecht, *Handbook of Employee Engagement: Perspectives, Issues, Research and Practice*, pp: 229-244. UK: Edward Elgar Publishing Limited.
- Bakker, Arnold B., Albrecht, Simon L dan Leiter, Michael P. 2011. Key questions regarding work engagement. *European Journal of Work and Organizational Psychology*, Volume 20, No. 1, pp: 4-28.
- Bakker, Arnold B dan Demerouti, Evangelia. 2008. Towards a model of work engagement. *Career Development International*, Volume 13, No. 3, pp: 209-223.
- _____. 2011. The job demands-resources model: Challenges for future research. *Journal of Industrial Psychology*, Volume 37, No. 2, pp: 974-982.

- Bakker, Arnold B., Demerouti, Evangelia dan Schaufeli, Wilmar B. 2003. Dual processes at work in a call centre: an application of the job demands-resources model. *European Journal of Work and Organizational Psychology*, Volume 12, No. 4, pp: 393–417.
- Bakker, Arnold B., Demerouti, Evangelia., Taris, Toon W., Schaufeli, Wilmar B dan Schreurs, Paul J.G. 2003. A multigroup analysis of the job demands-resources model in four home care organizations. *International Journal of Stress Management*, Volume 10, No. 1, pp: 16-38.
- Baker, AB., Schaufeli, W.B. 2008. Positive organizational behavior: engaged employee in flourishing organizations. *Journal Of Organizational Behavior*: 29, 147-154
- Bakker, Arnold B., Gierveld, J.H dan Rijswijk, K Van. 2006. *Succesfactoren bij vrouwelijke schoolleiders in het primair onderwijs: een onderzoek naar burnout, bevlogenheid en prestaties* (Success factors among female school principals in primary teaching: a study on burnout, work engagement and performance), pp: 3-28. Diemen: Right Management Consultants.
- Bakker, Arnold B dan Leiter, Michael P. 2010. *Work engagement: a handbook of essential theory and research*, pp: 181-196. New York: Psychology Press.
- Bakker, AB., Schaufeli, W.B., Leiter, M.P., & Taris, T.W. 2008. Work engagement: an emerging concept in occupational health psychology. *Work and Stress: An International Journal of Work, Health and Organizations*. Volume 22. Issue 3, 187-200
- Bandura, Albert. 1977. *Social learning theory*, pp: 79-85. New Jersey: Prentice Hall.
- _____. 1982. Self-efficacy mechanism in human agency. *American Psychologist*, Volume 37, No. 2, pp: 122-147.
- _____. 1994. *Self-efficacy*, pp: 2-15. New York: Academic Press.
- _____. 1997. *Self-efficacy in changing societies*, pp: 1-45. New York: Cambridge University Press.
- Ballout, Hassan I. 2009. Career commitment and career success: moderating role of self-efficacy. *Career Development International*, Volume 14, No. 7, pp. 655-670.
- Baron, Robert A dan Byrne, Donn. 2003. *Psikologi sosial jilid 1*, pp: 183-186. Jakarta: Erlangga.
- Blessing White Research. 2013. *Employee engagement: research update January 2013*, pp: 3-9. USA: GP Strategies.

- Buckingham, Marcus dan Coffman, Curt. 1999. *First, break all the rules: what the world's greatest managers do differently*, pp: 43-45. United States of America: Simon & Schuster.
- Cartwright, S., Dan Holmes, N. 2006. The meaning of work: the challenge of regaining employee engagement and reducing cynicism. *Human Resource Management Review*. Volume 16. Issue 2, 199-208
- Carver, Charles S and Scheier, Michael F. 2002. Optimism. Edited by Snyder dan Lopez, *Handbook Of Positive Psychology*, pp: 231-243. New York: Oxford University Press.
- _____. 2003. Optimism. Edited by Lopez dan Snyder, *positive psychological assessment: A handbook models and measures*, pp: 75-89. US: American Psychological Association.
- _____. 2009. Optimism. Edited by Lopez, *The encyclopedia of positive psychology*, pp: 656-663. United Kingdom: Wiley Blackwell.
- Cetin, Fatih. 2011. The effect of the organizational psychological capital on the attitudes of commitment and satisfaction: a public sample in turkey. *European Journal of Social Sciences*, Volume 21, No. 3, pp: 373-380.
- Chang, Edward C. 2001. *Optimism & pessimism: implications for theory, research, and practice*, pp: 257-280. US: American Psychological Association.
- Chaudary, Richa., Rangnekar, Santosh and Barua, Mukesh Kumar. 2012. Impact of occupational self-efficacy on employee engagement: an Indian perspective. *Journal of the Indian Academy of Applied Psychology*, Volume 38, No. 2, pp: 329-338.
- Chen, Gilad., Gully, Stanley M and Eden, Dov. 2001. Validation of a new general self-efficacy scale. *Organizational Research Methods*, Volume 4, No. 1, pp: 62-83.
- Cherian, Jacob dan Jacob, Jolly. 2013. Impact of self-efficacy on motivation and performance of employees. *International Journal of Business and Management*, Volume 8, No. 14, pp: 80-88.
- Chughtai, A.A & Buckley, F. (2008). Work engagement and its relationship with state and trait trust: a conceptual analysis. *Journal Of Behavioral And Applied Management*. Institute Of Behavioral And Applied Management, 47-71
- CIPD. 2007. *Employee engagement: Research report*, pp: 1-3. London: Chartered Institute of Personnel and Development.
- Dale Carnegie Training. 2012. *What drives employee engagement and why it matters*, pp: 2-3. US: Dale Carnegie & Associates.

- Das, Sarit Prava., Narendra, Preeti and Mishra, Parna. 2013. Drivers of employee engagement: A study in Indian manufacturing sector. *International Journal of Current Research*, Volume 5, No. 7, pp: 1981-1987.
- Debora Sowa, Robin Huntington, Steven Hutchison,. 1986. Perceived organizational support. *Journal of Applied Psychology*. Vol.71. No.3.500-507.
- Department for Work and Pensions. 2010. *Managing attendance and employee turnover*, pp: 26. London: Acas Publications.
- Duran, M. Auxiliadora., Extremera, Natalio dan Rey, Lourdes. 2010. Analyzing the contribution of emotional intelligence and core self-evaluations as personal resources to employee engagement. Edited by Albrecht, *Handbook of Employee Engagement: Perspectives, Issues, Research and Practice*, pp: 209-217. UK: Edward Elgar Publishing Limited.
- Ellis, Christian M dan Sorensen, Aaron. 2007. Assessing employee engagement: the key to improving productivity. *Perspectives*, Volume 15, No.1, pp: 1-9.
- Eisenberger, R., Armeli, S., Barbara, R., Patrick D. L., Linda, R. 2001. Reciprocation of perceived organizational support. *Journal of Applied Psychology*. Vol.86.No.1.42-51.
- Fleck, S. and Inceoglu, I. 2010. A comprehensive framework for understanding and predicting engagement. Edited by Albrecht, *Handbook of Employee Engagement: Perspectives, Issues, Research and Practice*, pp: 31-42. UK: Edward Elgar Publishing Limited.
- Fredrickson, Barbara L. 2001. The role of emotions in positive psychology: The broaden and build theory of positive emotions. *American Psychologist*, Volume 56, No. 3, pp: 218-226.
- Gallup. 2006. Gallup study: engaged employees inspire company innovation. *The Gallup Management Journal*. Edisi: 12 Oktober 2006. Tersedia pada: <http://gmj.gallup.com/content/24880/Gallup-Study-Engaged-Employees-Inspire-Company.aspx>. 6 November 2013, 12:34.
- Gibbons, John. 2006. *Employee engagement: a review of current research and its implications*, pp: 5. United State of America: The Conference Board, Inc.
- Gillham, Jane E., Shatte, Andrew J., Reivich, Karen J dan Seligman, Martin E. P. 2001. Optimism, pessimism, and explanatory style. Edited by Chang, *Optimism & Pessimism: Implications for Theory, Research, and Practice*, pp: 53-75. US: American Psychological Association.
- Hadi, Sutrisno. 2004. *Statistik jilid dua*, pp: 182. Yogyakarta: Andi Offset.
- Hameed, Abdul dan Waheed, Ameer. 2011. Employee development and its affect on employee performance a conceptual framework. *International Journal of Business and Social Science*, Volume 2 No. 13, pp: 224-229.

- Hatchett, Gregory T dan Park, Heather L. 2004. Relationships among optimism, coping style, psychopathology, and counseling outcome. *Personality and Individual Differences*, 36, pp: 1755-1769.
- Harter, J.K., Schmidt, F.L., Hayes, T.L (2002). Business-unit-level relationship between employees satisfaction, employee engagement, and business outcomes: a meta-analysis. *Journal Of Applied Psychology*, 87, 268-279
- Hefferon, Kate dan Boniwell, Ilona. 2011. *Positive psychology: theory, research and applications*, pp: 95-96. New York: McGraw-Hill Companies.
- Heuven, Ellen., Bakker, Arnold B., Schaufeli, Wilmar B dan Huisman, Noortje. 2006. The role of self-efficacy in performing emotion work. *Journal of Vocational Behavior*, 69, pp: 222-235.
- Hobfoll, Stevan E. 1989. Conservation of resources: a new attempt at conceptualizing stress. *American Psychologist*, Volume 44, No. 3, pp: 513-524.
- Jerusalem, Matthias dan Mittag, Waldemar. 1997. Self-efficacy in stressful life transitions. Edited by Bandura, *Self-Efficacy in Changing Societies*, pp: 177-201. New York: Cambridge University Press.
- Judge, Timothy A dan Bono, Joyce E. 2001. Relationship of core self-evaluations traits, self-esteem, generalized self-efficacy, locus of control, and emotional stability, with job satisfaction and job performance: A meta-analysis. *Journal of Applied Psychology*, Volume 86, No. 1, pp: 80-92.
- Judge, Timothy A., Thoresen, Carl J., Bono, Joyce E dan Patton, Gregory K. 2001. The job satisfaction-job performance relationship: a qualitative and quantitative review. *Psychological Bulletin*, Volume 127, No. 3, pp: 376-407.
- Kahn, William. A. 1990. Psychological conditions of personal engagement and disengagement at work. *Academy of Management Journal*, Volume 33, No.4, pp: 692-724.
- Kahn, William. A. 2010. The essence of engagement: Lessons from the field. Edited by Albrecht, *Handbook of employee engagement: Perspectives, issues, research and practice*, pp: 20-30. UK: Edward Elgar Publishing Limited.
- Khalatbari, Javad. 2012. The relationship between optimism and mental health in a non-profit student branch of tonekabon. *Indian Journal of Fundamental and Applied Life Sciences*, Volume 2, No. 2, pp: 304-311.
- Kreitner, Robert dan Kinicki, Angelo. 2005. *Perilaku organisasi*, pp: 168-169. Jakarta: Salemba Empat.

- Kular, S., Gatenby, M., Rees, C., Soane, E., & Truss, K. 2008. *Employee engagement: A literature review*. United Kingdom: University Kingston.
- Llorens, Susana., Schaufeli, Wilmar B., Bakker, Arnold B dan Salanova, Marisa. 2007. Does a positive gain spiral of resources, efficacy beliefs and engagement exist? *Computers in Human Behavior*, 23, pp: 825-841.
- Luthans, Fred. 2002. Positive organizational behavior: Developing and managing psychological strenght. *Academy Of Management Executive*, 16, 57-72
- Luthans, F. & Peterson, S. J. 2002. Employee engagement and manager self-efficacy. Implication for managerial effectiveness and development. *The Journal of Management Development*, 21, 376-387.
- Luthans, F.& Jensen, Susan M. 2002. *Hope: a new resource development review*, 1, 304-322.
- Luthans, Fred. 2011. *An evidence-based approach: Organizational behavior*, pp: 204-205. New York: McGraw-Hill Companies
- Luthans, F., Avey, J. B., Avolio, Bruce J., Norman, Steven M dan Combs, Gwendolyn M. 2006. Psychological capital development: toward a micro-intervention. *Journal of Organizational Behaviour*, 27, pp: 387-393.
- Luthans, Fred., Luthans, Kyle W. dan Luthans, Brett C. 2004. Positive psychological capital: Beyond human and social capital. *Business Horizons*, Volume 47, No. 1, pp: 45-50.
- Luthans, Fred, Youssef, Carolyn M., dan Avolio, Bruce J. 2007. *Psychological capital: Developing the human competitive edge*, pp: 3-54. UK: Oxford University Press.
- Luthans, Fred dan Youssef, Carolyn M. 2004. Human, social, and now positive psychological capital management: investing in people for competitive advantage. *Organizational Dynamics*, Volume. 33, No. 2, pp: 143-160.
- Damasio, B. F., & Borsa, J. C. (2011). 14-Item Resilience Scale (RS-14): Psychometric Properties of Brazilian Version. *Journal of Nursing Measurement* , 19, 131-145.
- Lopez, S. J., & Snyder, C.R. 2011. *Oxford handbook of positive psychology. Second edition*. New York: Oxford University Press.
- Maddux, James E. 2002. Self-efficacy: the power of believing you can. Edited by Snyder and Lopez, *Handbook of Positive Psychology*, pp: 277-287. New York: Oxford University Press.

- Macey, William H and Schneider, Benjamin. 2008. The meaning of employee engagement. *Industrial and organizational psychology (1)*, pp: 3-30.
- Macey, William H., Schneider, B., Barbera, Karen M., & Young, Scott A. 2009. *Employee engagement: tools for analysis, practice, and competitive advantage*. United Kingdom: Valtera Corporation.
- Maslach, C., Schaufeli, W.B., Leiter, M.P. 2001. Job burnout. *Annual review of psychology*, 52, 397-422
- McBain, R. 2007. The practice of engagement: research into current employee engagement practice. *Strategic HR Review*, Vol. 6 Iss: 6, Pp.16 - 19
- Mercer. 2007. Exploring the global drivers of employee engagement. *Marsh & mclennan companies*. Edisi: 26 September 2007. Tersedia pada: www.mercer.com/referencecontent.htm?idContent=1281670. 6 November 2013, 14:25.
- Meesala, A. 2011. Identification of engaged employee groups: who all are the full-throttles, the wet-behind-the-ears, and the past-the-primers in India? *Interdisciplinary Journal of Contemporary Research in Business*, Volume. 3, No. 5, pp: 157-181.
- Myers, David. 2002. *Social psychology 7th edition*, pp: 54-62. New York: The McGraw-Hill Companies.
- Nastiti, F., Arijanto, S., dan Yuniati, Y. (2014). *Usulan peningkatan employee engagement pada dosen itenas*. Reka Integra. Jurnal Teknik Industri. Institut teknologi Nasional Bandung Vol. 2 No 1.
- Office of Chief Researcher. 2007. *Employee engagement in the public sector: a review of literature*, pp: 1-50. Edinburgh: Scottish Executive.
- Page, Liam F dan Donohue, Ross. 2004. Positive psychological capital: A preliminary exploration of the construct. *Working Paper Series 51/04*, pp: 2-10. Monash University.
- PB, Triton. 2006. *SPSS 13.0. Terapan: Riset statistik parametrik*, pp: 248. Yogyakarta: Andi Offset.
- Peterson, Christopher. 2000. The future of optimism. *American Psychologist*, Volume 55, No. 1, pp: 44-55.
- Peterson, Christopher dan Steen, Tracy A. 2002. Optimistic explanatory style. Edited by Snyder dan Lopez, *Handbook of Positive Psychology*, pp. 244-256. New York: Oxford University Press.
- Priyatno, Duwi. 2008. *Mandiri belajar SPSS (Statistical Product and Service Solution): Untuk analisis data dan uji statistik*, pp: 25-79. Yogyakarta: Mediakom.
- _____. 2009. *5 jam belajar olah data dengan SPSS 17*, pp: 152. Yogyakarta: Andi Offset.

- _____. 2012a. *Belajar cepat olah data statistik dengan SPSS*, pp: 69-93. Yogyakarta: Andi Offset.
- _____. 2012b. *Cara kilat belajar analisis data dengan SPSS 20*. Yogyakarta: Andi Offset.
- Rasmussen, Heather N dan Wallio, Stephanie C. 2008. The health benefits of optimism. Edited by Lopez, *Positive psychology: Exploring the best in people*, pp: 131-150. United State of America: Praeger Publishers.
- Rashid, Hafiz Abdur., Asad, Ammar dan Ashraf, Mian Muhammad. 2011. Factors persuading employee engagement and linkage to personal and organizational performance. *Interdisciplinary Journal of Contemporary Research in Business*, Volume 3, No. 5, pp: 98-108.
- Rauf, Khalida. 2010. The impact of positive attitudes on job satisfaction. *Pakistan Business Review*, pp: 329-344.
- _____. 2010b. The relationship of optimism and job satisfaction in business school. *Pakistan Business Review*, pp: 294-308.
- Rayton, B., Dodge, T., Analeze, G. D., Marks, dan Spencer. 2012. *The evidence: Employee engagement task force "nailing the evidence" workgroup*, pp: 4-5. UK: University of Bath School of Management.
- Reivich, Karen and Gillham, Jane. 2003. Learned optimism: The measurement of explanatory style. Edited by Lopez and Snyder, P. *Positive psychological assessment: A handbook models and measures*, pp: 57-74. US: American Psychological Association.
- Riduwan. 2009. *Metode dan teknik menyusun tesis*, pp: 63-218. Bandung: Alfabeta.
- Rhoades, Linda., Eisenberger. Robert., Stephen Armeli. 2001. Affective commitment to the organization: The contribution of perceived organizational support. *Journal of Applied Psychology*. Vol.86.No.5. 825-836.
- _____, Eisenberger, Robert. 2002. Perceived organizational support: A review of the literature. *Journal of Applied Psychology*. Vol.87.No.4. 698-714.
- Robertson, Gemma and Markwick, Carl. 2009. *Employee engagement: A review of current thinking*, pp: 7. UK: Institute for Employment Studies.
- Robertson, Ivan T. & Cooper, Cary L. 2009. Full engagement: The integration of employee engagement and psychological well-being. *Leadership & Organizational Development Journal*, 31, 324-336.

- Robinson, D., Perryman, S and Hayday, S. 2004. *The drivers of employee engagement*, pp: 9-23. UK: The Institute for Employment Studies.
- Rothbard, Nancy P. 2001. Enriching or depleting? The dynamic of engagement in work and family roles. *Administrative Science Quarterly*, 46, pp: 655-684.
- Saks, A.M. 2006. Antecedents and consequences of employee engagement. *Journal Of Managerial Psychology*. Emerald Group Publishing Limited. Vol. 21 No. 7.Pp. 600-619
- Saks, Jamie A and Gruman, Alan M. 2010. Performance management and employee engagement. *Human Resource Management Review*, 21, 123-136.
- _____. 2011. Getting newcomers engaged: the role of socialization tactics. *Journal of Managerial Psychology*, Volume 26, No. 5, pp: 383-402.
- Schaufelli, W. B., Salanova, M., Roma, V. G., and Bakker, Arnold B. 2002. The measurement of engagement and burnout: A two sample confirmatory factor analytic approach. *Journal of Happiness Studies*, 3, pp: 71-92.
- Schaufeli, Wilmar B., Bakker, Arnold B and Salanova, M. 2006. The measurement of work engagement with a short questioner. *Educational and Psychological Measurement*, Volume 66, No. 4, pp: 701-716.
- Schaufeli, WB dan Baker, A.B. 2004. Job demands, job resources, and their relationship with burnout and engagement: A multi-sample study. *Journal of Organizational Behavior*, 25, 293-315
- Schaufeli, W.B& Bakker, A.B. 2003. *UWES. Utrecht Work Engagement Scale*. Preliminary Manual. Occupational Health Psychology Unit. Utrecht University
- Scheier, Michael F., Carver, Charles S dan Bridges, Michael W. 1994. Distinguishing optimism from neuroticism (and trait anxiety, self-mastery, and self-esteem): A reevaluation of the life orientation test. *Journal of Personality and Social Psychology*, Volume 67, No. 6, pp: 1063-1078.
- Schohat, Lior M dan Gadot, Eran Vigoda. 2010. Engage me once again: is employee engagement for real, or is it same lady different dress? Edited by Albrecht, *Handbook of Employee Engagement: Perspectives, Issues, Research and Practice*, pp: 98-107. UK: Edward Elgar Publishing Limited.
- Schwarzer, Ralf dan Fuchs, Reinhard. 1997. Changing risk behavior and adopting health behavior: the role of self-efficacy beliefs. Edited by Bandura, *Self-Efficacy in Changing Societies*, pp: 259-288. New York: Cambridge University Press.
- Segers, Jesse., Prins, Peggy De and Brouwers, Sonja. 2010. Leadership and engagement: A brief review of the literature, a proposed model, and practical implications. Edited by Albrecht,

- Handbook of Employee Engagement: Perspectives, Issues, Research and Practice*, pp: 149-158. UK: Edward Elgar Publishing Limited.
- Segerstrom, Suzanne C., Taylor, Shelley E., Kemeny, Margaret E, and Fahey, John L. 1998. Optimism is associated with mood, coping, and immune change in response to stress. *Journal of Personality and Social Psychology*, Volume 74, No. 6, pp: 1646-1655.
- Seligman, Martin E. P. 1990. *Learned optimism: How to change your mind and your life*, pp: 44-51. New York: A Division of Random House.
- _____. 2004. *Authentic happiness: Using the new positive psychology to realize your potential for lasting fulfillment*, pp: 30. New York: Free Press.
- _____. 1998. *Learned optimism*. New York: Pocket Books
- Shepperd, James A., Maroto, JoAnn J dan Pbert, Lori A. 1996. Dispositional optimism as a predictor of health changes among cardiac patients. *Journal of Research in Personality*, Volume 30, No. 38, pp: 517-534.
- Social Issue Research centre. 2009. *Optimism: A report from the social issue research centre*, pp: 7. UK: The National Lottery.
- Shore, Lynn M., SandyJ.Wayne.1993. Commitment and employee behavior: comparison of affective commitment and continuance commitment with perceived organizational support. *Journal of Applied Psychology*.Vol.5. No.78.774-780.
- Shuck, M. B., Rocco, Tonette S.& Albornoz, Carlos A. 2010. Exploring employee engagement from employees' perspective: implications for HRD. *Journal of European Industrial Training*, 35, 300-325.
- Snyder, C. R. 1994. *Psychology of hope: You can get there from here*. New York: The Free Press.
- Srivastava, Sanjay dan Angelo, Kimberly. 2009. Optimism, effects on relationships. Edited by Reis and Sprecher, *Encyclopedia of Human Relationships*, pp: 1181-1184. United States of America: Sage Publications.
- Stein, Steven J dan Book, Howard E. 2001. *The EQ edge: Emotional intelligence and your success*, pp: 52-234. Canada: John Wiley & Sons.
- Sugiyono. 2013. *Statistika untuk penelitian*, pp: 231. Bandung: Alfabeta.
- Suryabrata, Sumadi. 2003. *Metodologi penelitian*, pp: 29-60. Jakarta: PT. Raja Grafindo Persada.
- Sweetman, David dan Luthans, Fred. 2010. The power of positive psychology: psychological capital and work engagement. Edited by Bakker dan Leiter, *Work Engagement: A Handbook of Essential Theory and Research*, pp: 54-68. New York: Psychology Press.

- Tariq, Muhammad Naeem., Ramzan, Muhammad dan Riaz, Aisha. 2013. The impact of employee turnover on the efficiency of the organization. *Interdisciplinary Journal of Contemporary Research in Business*, Volume 4, No. 9, pp: 700-711.
- Tims, Maria., Bakker, Arnold B dand Xanthopoulou, Despoina. 2011. Do transformational leaders enhance their followers daily work engagement?. *The Leadership Quarterly*, 22, pp: 121-131.
- Terry, George R dan Rue, Leslie W. 2005. *Dasar-dasar manajemen*, pp: 74. Jakarta: Bumi Aksara.
- Tuten, Tracy L and Neidermeyer, Presha E. 2004. Performance, satisfaction, and turnover in call centers: The effects of stress and optimism. *Journal of Business Research*, 57, pp: 26-34.
- Vance, Robert J. 2006. *Employee engagement and commitment: a guide to understanding, measuring and increasing engagement in your organization*, pp: 5-21. United State of America: The SHRM Foundation.
- Wagnild, G. 2009. A review of the resilience scale. *Journal of nursing measurement*, 17, 105-113.
- Wellins, Richard S., Bernthal, Paul dan Phelps, Mark. 2008. *Employee engagement: the key to realizing competitive advantage*, pp: 2-27. Development Dimensions International (DDI) Inc.
- Worsch, Carsten and Scheier, Michael F. 2002. Personality and quality of life: the importance of optimism and goal adjustment. *Quality of Life Research*, Volume 12, No. 1, pp: 59-72.
- Xanthopoulou, Despoina., Bakker, Arnold B., Demerouti, Evangelia and Schaufeli, Wilmar B. 2007. The role of personal resources in the job demands-resources model. *International Journal of Stress Management*, Volume 14, No. 2, pp: 121-141.
- _____. 2009. Work engagement and financial returns: a diary study on the role of job and personal resources. *Journal of Occupational and Organizational Psychology*, 82, pp: 183-200.
- Yakin, Mustafa and Erdil, Oya. 2012. Relationships between self-efficacy and work engagement and the effects on job satisfaction: A survey on certified public accountants. *Journal of Personality and Social Psychology*, Volume 74, No. 6, pp: 1646-1655.